

## Convertible Push End Trucks HPC 500 Series

For assembly, maintenance, machining or general industrial operations, HPC 500 series end truck kits offer a medium duty, push end truck design that can be assembled for either top running or underhung cranes. Kits include: two end trucks; rubber bumpers; bridge beam fastener set; trolley stops; beam fabrication instructions; and assembly and installation guide.

### Benefits to count on:

- Fully machined frames are convertible for either top running or underhung use.
- Frames are fabricated from structural steel for optimal strength and rigidity.
- Wheels are cast iron and precision machined to roll smoothly on either flat or tapered flanges. Each wheel features a sealed deep groove ball bearing.
- All-bolted for ease of assembly.
- Drop stops and rail sweeps standard.
- Longer or shorter end truck lengths are available—consult factory.

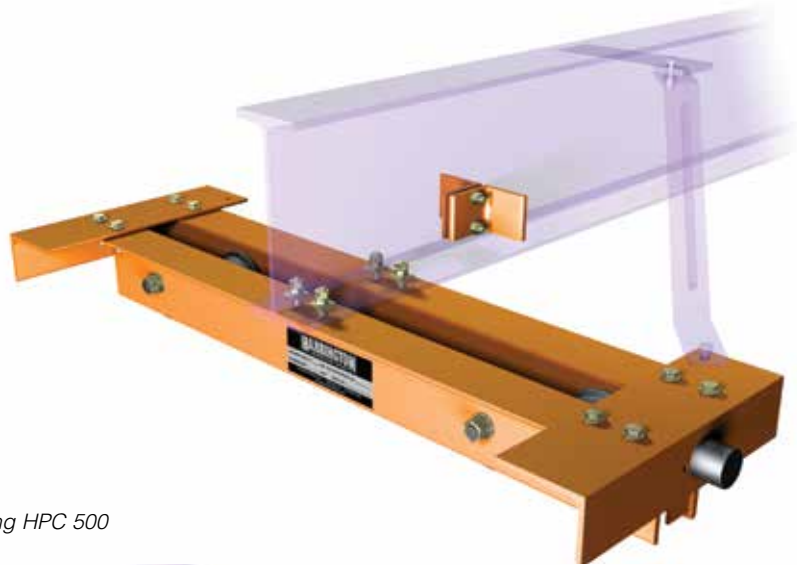

*Top Running HPC 500*



*Underhung HPC 500*

**HPC 500 — CONVERTIBLE PUSH END TRUCK — SPECIFICATIONS AND DIMENSIONS**

Cap. (Tons)	Max. Span (ft)	End Truck Product Code	T* Flange or Rail Head Width (in)		D** (in)	M** End Truck Frame Width (in)	N Runway Ctr. Line to Outer Edge of ET (in)	Q Wheel Tread Dia. (in)	X Width Beyond Span (in)	Y Wheel Running Surface to Bridge Beam (in)	R Wheel Running Surface to Bridge Beam (in)	End Truck Weight (lbs/pr)
			Top Running	Underhung								
1/2	24	HPC505	1.5-6	3-6	T + 4-3/4	T + 7.3	M/2	3.12	10 1/8 - T/2	4.3	1.2	156
1		HPC510		T + 8.3		4.00		5.3		1.2	214	
2		HPC520	3.3-6	4.88		5.9		1.1		270		

\*Consult customer service for widths or flanges greater than 6 inches.

\*\*Formula shown is for S beams & ASCE rail—add 1/4 inch for W beams and rectangular bar.

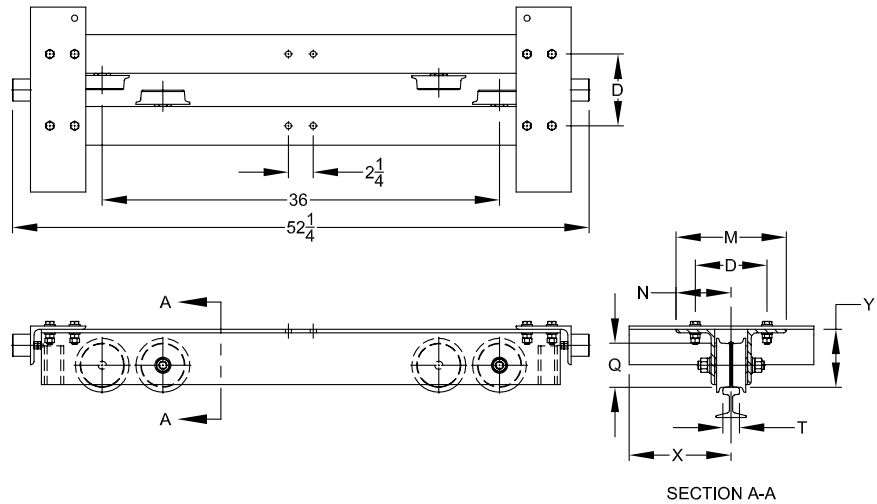

HPC 500 Top Running End Trucks  
Dimensions in inches

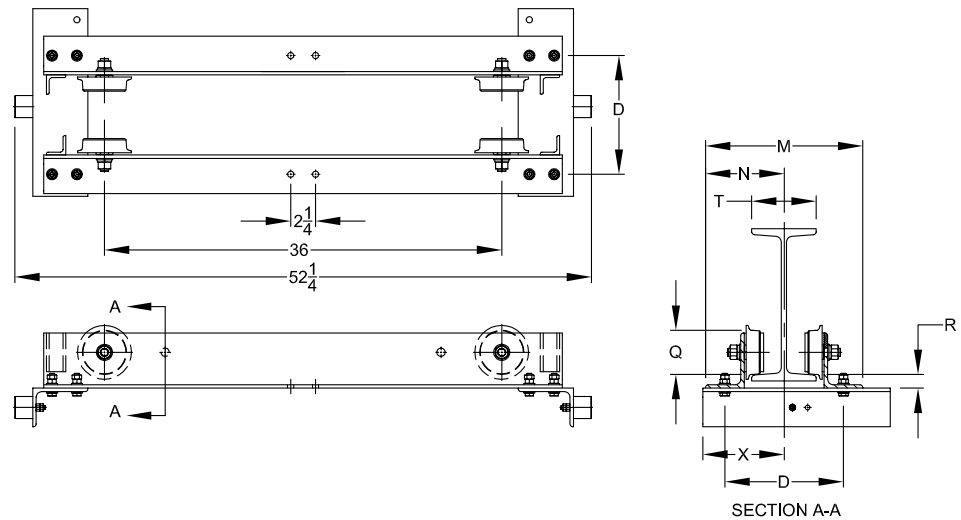

HPC 500 Underhung End Trucks  
Dimensions in inches