

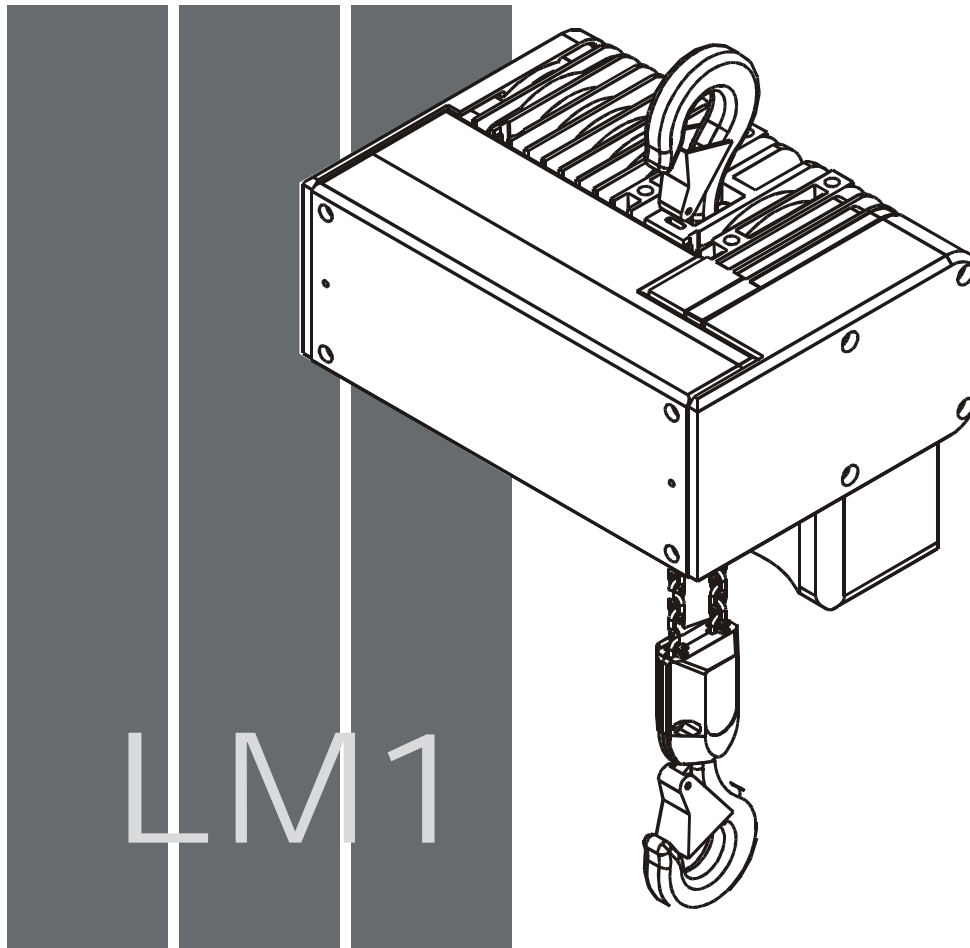

# LoadMate®

## LM1 ELECTRIC CHAIN HOIST



# INSTALLATION & MAINTENANCE MANUAL

JOB NO.: \_\_\_\_\_

SERIAL NO.: \_\_\_\_\_

(RECORD HOIST SERIAL NUMBER FOR FUTURE REFERENCE)

*Authorized Sales & Service*

**J. HERBERT CORPORATION**

Call 1-800-255-0588  
407-846-0588 Fax: 846-1066  
info@jherbertcorp.com

Visit us online:  
[www.jherbertcorp.com](http://www.jherbertcorp.com)



R&M Materials Handling, Inc  
Springfield, Ohio USA  
☎: 800 955-9967  
[www.rmhoist.com](http://www.rmhoist.com)

LoadMate® Chain Hoist  
LM1 Installation & Maintenance Manual

April 2005

LEAVE THIS PAGE BLANK



## TABLE OF CONTENTS

<b>1</b>	<b>INTRODUCTION.....</b>	<b>1</b>
1.1	Contact Information .....	1
1.2	Warranty.....	1
1.3	Disclaimer.....	1
1.4	Safety .....	2
1.5	Placards and Instructions .....	4
<b>2</b>	<b>INSTALLATION.....</b>	<b>5</b>
2.1	General.....	5
2.2	Lubrication.....	5
2.3	Mounting.....	5
2.4	Load Hook Throat Opening .....	6
2.5	Electrical Connection .....	6
2.6	Three Phase Power Connections.....	7
2.7	Single Phase Power Connections .....	8
<b>3</b>	<b>INITIAL START-UP .....</b>	<b>9</b>
3.1	General.....	9
3.2	Correcting the Direction of Hook Travel .....	9
3.3	Operational Checks – No Load .....	9
3.4	Operational Checks – With Load.....	10
<b>4</b>	<b>HOIST OPERATION.....</b>	<b>11</b>
<b>5</b>	<b>MAINTENANCE.....</b>	<b>13</b>
5.1	Basic Hoist Construction .....	13
5.2	Motor / Body .....	13
5.3	Hoist Motor Brake and Load-Limiting Device .....	14
5.3.1	Slip Clutch Operation .....	14
5.3.2	Slip Clutch Adjustment after Installation.....	16
5.3.3	Hoist Motor Brake Adjustment (See Figure 5.2) .....	17
5.4	Load Chain .....	17
5.4.1	General.....	17
5.4.2	Maintenance Inspection .....	17
5.4.3	Load Chain Specifications (see Figure 5.3) .....	19
5.4.4	Removing the Load Chain.....	19
5.4.5	Installing the Load Chain.....	20
5.5	Fall Stop Assembly.....	21
5.5.1	General.....	21
5.5.2	Fall Stop Installation .....	21
5.6	Chain Container .....	22
5.7	Limit Switches .....	23
5.7.1	Upper and Lower Travel Safety Limit Switch .....	23
5.7.2	Upper and Lower Rotary Travel Limit Switch (Optional Only on 3-Phase units) .....	23
5.8	Hooks .....	24
5.8.1	General.....	24
5.8.2	Inspection .....	25
5.8.3	Hook Dimensions and Specifications.....	25
5.8.4	Top Hook .....	26
5.9	Controls .....	27
5.9.1	General.....	27
5.9.2	Control Fuses .....	27
5.10	Control Panel Layout – Three Phase – Two Speed .....	28
5.11	Control Panel Layout – Single Phase – Single Speed – 115 Volt.....	29
5.12	Wiring Diagram – Three Phase – Two-speed Hoist.....	30



5.13	Wiring Diagram – Three Phase – Pushbutton.....	31
5.14	Wiring Diagram– Single Phase – Connections and Components.....	32
5.15	Wiring Diagram – Single Phase – Power Circuit.....	33
5.16	Wiring Diagram – Single Phase – Control Circuit.....	34
5.17	Wiring Diagram – Single Phase – Push Button Control Circuit.....	35
<b>6</b>	<b>PREVENTATIVE MAINTENANCE .....</b>	<b>37</b>
6.1	Maintenance and Inspection Table .....	37
6.2	Lubrication.....	38
6.3	Recommended technical support for various spare parts .....	39
6.4	Screw Tightening Torque (lb-ft) Specifications.....	39
6.5	Troubleshooting .....	40
<b>7</b>	<b>PARTS ILLUSTRATION.....</b>	<b>42</b>
7.1	Hoist Body .....	42
7.2	Helical Gear Mechanism & Brake .....	44
7.3	Lifting Assembly .....	46
7.4	Control Panel Assembly – 3 Phase Power Supply.....	48
7.5	Control Panel Assembly – 115 Volt 1-Phase Power Supply .....	49
7.6	Push Button Assembly – Vertical Pairs of Buttons.....	50
7.7	Pushbutton Assembly – Horizontal Pairs of Buttons.....	52



## 1 INTRODUCTION

### 1.1 Contact Information

Please do not hesitate to use for following contact information in the event that you may need assistance:

**R&M MATERIALS HANDLING, INC.**  
4501 Gateway Boulevard  
Springfield, OH 45502

**General Telephone:** 937 - 328-5100  
**Toll Free Telephone (US):** 800 - 955-9967

**General Fax:** 937 - 325-5319  
**Parts Dept. Fax (US):** 800 - 955-5162  
**Parts Dept. Fax (other):** 937 - 328-5162

**Website:** [www.rmhoist.com](http://www.rmhoist.com)

### 1.2 Warranty

**All sales are subject to the R&M MATERIALS HANDLING, INC. Standard Terms and Conditions of Sale and Product Warranty. Copies are available upon request from R&M MATERIALS HANDLING, INC. (also available from website) and are expressly incorporated by reference hereto.**

### 1.3 Disclaimer

This Manual has been prepared by **R&M MATERIALS HANDLING, INC.** to provide information and suggestions for hoist installation, maintenance, and inspection personnel. This manual should be used in conjunction with the **LoadMate® Electric Chain Hoist Operator's Manual** to teach safe operating practices to all personnel associated with hoist operations and maintenance.

It is **NOT** intended that the recommendations in this manual take precedence over existing plant safety rules and regulations or OSHA regulations. However, a thorough study of the following information should provide a better understanding of proper installation, maintenance, and inspection procedures that are to be followed in order to afford a greater margin of safety for people and machinery in the area of hoist operations.

It must be recognized that this is a manual of recommendations for the Hoist Installation, Maintenance, and Inspection personnel and its use is permissive not mandatory. It is the responsibility of the hoist owner to make personnel aware of all federal, state, and local codes and regulations. The owner is responsible for providing instruction and insuring that certain installation, maintenance, and inspection personnel are properly trained.

## 1.4 Safety



The Safety Alert Symbol is used in this manual to indicate hazards and to alert the reader to information that should be known, understood, and followed in order to avoid DEATH or SERIOUS INJURY.

### Read and understand this manual before using the hoist.

Important issues to remember during installation, operation, maintenance, and inspection are provided at the hoist control stations, at various locations on the hoist, in this manual, and in the [LoadMate® Electric Chain Hoist Operator's Manual](#). These issues are indicated by **DANGER**, **WARNING**, or **CAUTION** instructions or placards, that alert personnel to potential hazards, proper operation, load limitations, and more.



**DANGER:** Indicates an imminently hazardous situation, which, if not avoided, will result in death or serious injury.



**WARNING:** Indicates a potentially hazardous situation, which, if not avoided, could result in death or serious injury.



**CAUTION:** Indicates a potentially hazardous situation, which, if not avoided, may result in minor or moderate injury. It may also be used to alert against unsafe practices.

**Taking precedence over any specific rule, however, is the most important rule of all:**

### “USE COMMON SENSE”

It is a responsibility of the hoist owner / user to establish programs to:

1. Train and designate hoist operators, and
2. Train and designate hoist inspectors / maintenance personnel.

The words **SHALL** and **SHOULD** are used throughout this manual in accordance with definitions in the ASME B30 standards as follows:

**SHALL** indicates a rule is mandatory and must be followed.

**SHOULD** indicates a rule is a recommendation, the advisability of which depends on the facts in each situation.



Hoist operation, hoist inspection, and hoist maintenance personnel training programs should be based on requirements in accordance with the latest edition of:

- **ASME B30.16 Safety Standard for Overhead Hoists ( Underhung )**

Such training should also provide information for compliance with any Federal, State, or Local Code requirements, and existing plant safety rules and regulations.

If an overhead hoist is installed as part of an overhead crane or monorail system, training programs should also include requirements in accordance with the latest editions, as applicable, of:

- **ASME B30.2 Safety Standard for Overhead and Gantry Cranes, Top Running Bridge, Single or Multiple Girder, Top Running Trolley Hoist**
- **ASME B30.11 Safety Standard for Monorails and Underhung Cranes**
- **ASME B30.17 Safety Standard for Overhead and Gantry Cranes, Top Running Bridge, Single Girder, Underhung Hoist**

### NOTICE

It is a responsibility of the owner / user to install, inspect, test, maintain, and operate a hoist in accordance with the ASME B30.16 Safety Standard, OSHA Regulations, and ANSI / NFPA 70, National Electric Code. If the hoist is installed as part of a total lifting system, it is also the responsibility of the owner / user to comply with the applicable ASME B30 volume that addresses other types of equipment used in the system.

Further, it is the responsibility of the owner / user to require that all personnel who will install, inspect, test, maintain, and operate a hoist read the contents of this manual, [LoadMate® Electric Chain Hoist Operator's Manual](#), ASME B30.16 Safety Standards for Overhead Hoists (Underhung), OSHA Regulations, and ANSI / NFPA 70, National Electric Code. If the hoist is installed as part of a total lifting system, all personnel must also read the applicable ASME B30 volume that addresses other types of equipment used in the system.

### DANGER

Failure to read and comply with any one of the limitations noted in this manual can result in product failure, serious bodily injury or death, and / or property damage.

[R&M MATERIALS HANDLING, INC.](#) has no direct involvement or control over the hoist's operation and application. Conforming to good safety practices is the responsibility of the owner, the user, and it's operating personnel.

Only those Authorized and Qualified Personnel who have shown that they have read and have understood this manual and the [LoadMate® Electric Chain Hoist Operator's Manual](#) should be permitted to operate the hoist.

The owner / user **SHALL** insure that all Operators read and understand the [LoadMate® Electric Chain Hoist Operator's Manual](#) prior to operating the hoist.



## 1.5 Placards and Instructions

READ and OBEY all Danger, Warning, Caution, and Operating Instructions on the hoist and in this manual and [LoadMate® Electric Chain Hoist Operator's Manual](#). Make sure that all placards are in place and legible.

Failure to comply with safety precautions in this manual and on the hoist is a safety violation that may result in serious injury, death, or property damage.

## 2 INSTALLATION



Before installing, removing, inspection, or performing any maintenance on a hoist, the main switch shall be de-energized. Lock and tag the main switch in the de-energized position in accordance with ANSI Z244.1. Follow other maintenance procedures outlined in this manual and ASME B30.16.

### 2.1 General

Prior to installation, the unit shall be checked thoroughly for damage during shipment or handling at the job site.

Each complete electric chain hoist is load tested at the factory at 125% of the nameplate-rated capacity.

All hoists are designed for the type of mounting specified by the purchaser. The adequacy of the supporting members (monorail beams, cranes, hangers, supports, framing, etc.) is the responsibility of user / owner and shall be determined or verified by qualified personnel.

Read the instructions contained in this manual and the [LoadMate® Electric Chain Hoist Operator's Manual](#) as well as any other related manuals. Observe the warning tags attached to the unit before the installation is started.

### 2.2 Lubrication

The hoist gear case comes completely pre-lubricated with grease.

**Note:** Open trolley wheel gearing has not been greased at the factory. See the trolley manual for proper gear lubricant to use before installing hoist.

The load chain requires lubrication prior to first use. Chain lubricant is included with shipment of each new chain hoist.

### 2.3 Mounting

Below are three types of mounting:

1. Hook Mounted
2. Base Mounted
3. Coupling Mounted
4. Trolley Mounted – NOT SHOWN – is accomplished via a Hook or Trolley Coupling to the Trolley Assembly.

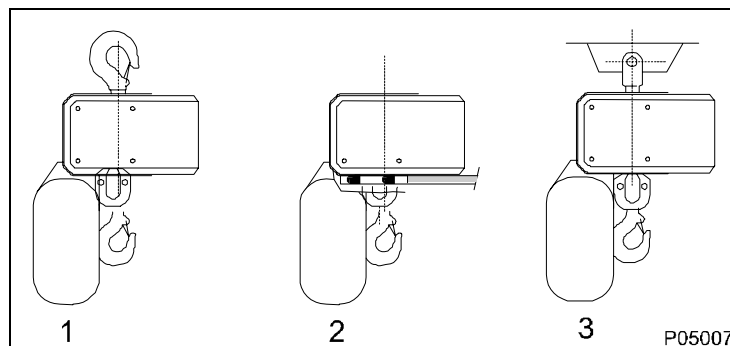

For all trolley-mounted hoists, refer to appropriate trolley manual for trolley installation instructions.

After a trolley-mounted hoist has been assembled to a beam, check for balance. Each trolley-mounted hoist is balanced at the factory for “as shipped” condition. Any auxiliary devices (radio control, lights, hose reels, etc.) furnished and mounted by “others” may require additional counterweight. Hoists must hang straight without a load or there will be a noticeable “kick” when a load is applied to hook. An unbalanced hoist / trolley may result in damage to equipment.

## 2.4 Load Hook Throat Opening



ANSI B30.16-1998 recommends that the throat opening of a load hook be measured and recorded prior to putting a hoist into service and that a gage be made to provide a quick visual inspection for a bent hook as required during routine inspections. Record this information before initial start-up. See Section 5.8 for more detailed hook information.

## 2.5 Electrical Connection

The user / owner must provide the main power supply hardware (cable, conductor bar, fuses, disconnect switch, etc.).



- Make sure that the power supply voltage is the same as that shown on hoist serial plate / nameplate.
- Make sure that fuses and other current overload devices are in place to protect the power supply.
- Make sure that power cable or conductors have sufficient capacity to maintain the hoist supply voltage by  $\pm 5$  percent of nominal voltage under all operating conditions. Poor voltage regulation may cause motor overheating or sluggishness, and chattering / inoperative motor brake(s) and controls.
- Do not use power supply cables with solid conductors.

## 2.6 Three Phase Power Connections

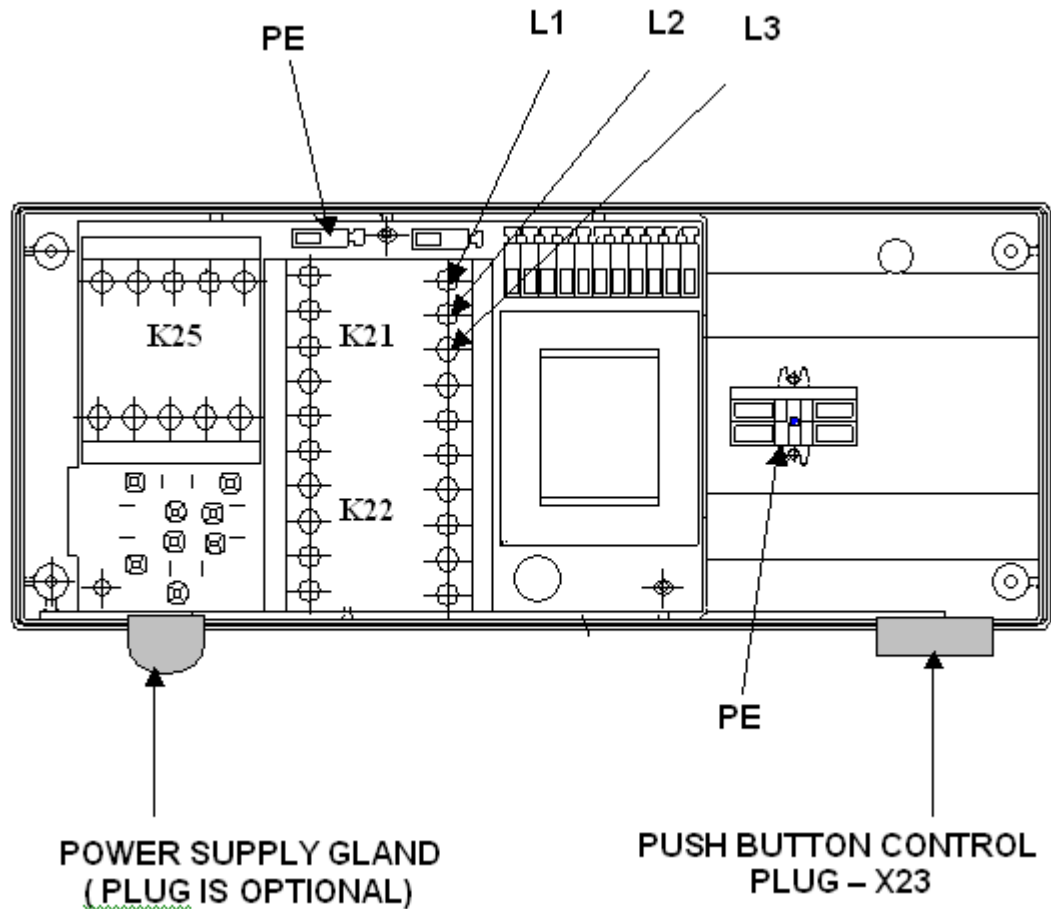

Figure 2.1

1. Remove control box cover.
2. Insert power supply cable through cable gland or assemble to (optional) plug.
3. Connect power leads L1, L2, and L3 to relay K21.
4. Connect ground wire PE (GRD) to terminal strip (2). Refer to wiring diagram.
5. Tighten terminal screws.
6. Tighten cable gland or (optional) connector to secure power cable.
7. Replace control box cover.
8. Attach pushbutton assembly to plug connection X23.

## 2.7 Single Phase Power Connections

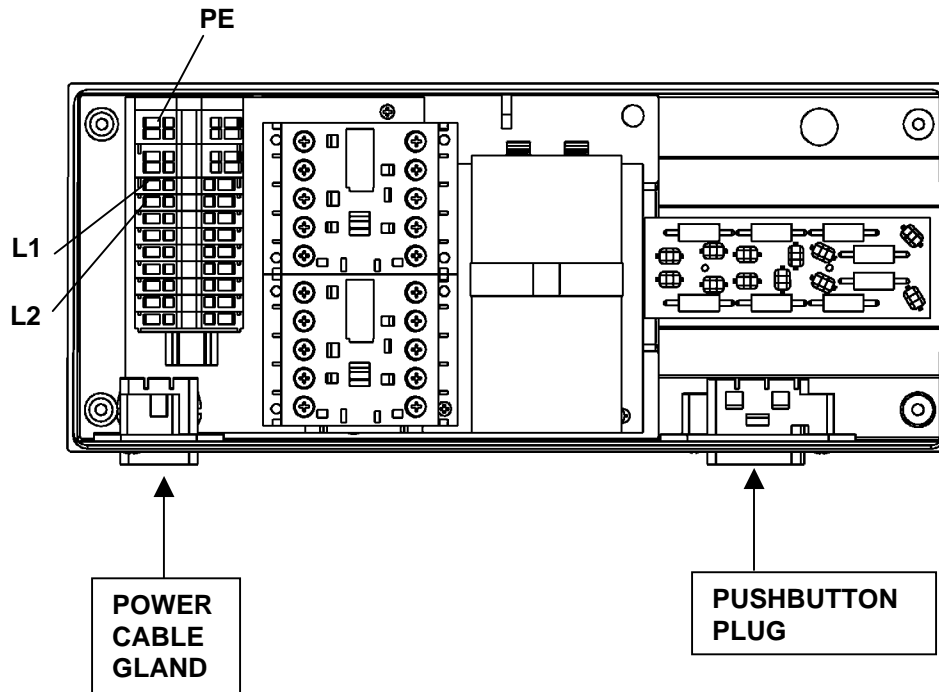

Figure 2.2

1. Remove control box cover.
2. Insert power supply cable through power cable gland (Figure 2.2).
3. Connect power leads L1 and L2 to terminal strip (Figure 2.2).
4. Connect ground wire PE to terminal strip (Figure 2.2). Refer to wiring diagram.
5. Insure terminals are tight
6. Tighten cable gland or connector (Figure 2.2) to secure power cable.
7. Replace control box cover.
8. Attach pushbutton assembly to plug (Figure 2.2).

### 3 INITIAL START-UP



Before connecting power to hoist, check all “motion” buttons on pendant control assembly to make sure that they operate freely without binding or sticking. Check pendant cable and strain relief connection to ensure that they are not damaged.

#### 3.1 General

Initial start-up procedures are as follows:

- Read all attached **WARNING** tags and placards affixed to hoist.
- Oil load chain generously over entire length of chain.
- Make sure that load chain is not twisted. If so, untwist load chain before using.
- Make sure fall stop is placed at least 6” [150 mm] from last chain link on free end.
- Install chain container.
- If furnished, make sure that trolley wheels have proper spacing in relation to beam flange. See appropriate trolley manual for details.
- Check direction of hook travel to make certain that it corresponds to respective control button that is depressed. That is, does hook travel “UP” when **UP BUTTON** is depressed? If OK, go to section 3.3. If not, proceed to section 3.2 for correcting direction of travel.

#### 3.2 Correcting the Direction of Hook Travel



**DO NOT change control leads in pushbutton enclosure or at motor relays. DO NOT change nameplates on pushbutton assembly. The upper/lower safety limit switch is wired in series with “UP” control circuit as furnished from factory. Changing pushbutton control leads or nameplates will prevent the upper safety travel limit switch from functioning properly.**

Reversing any two power leads of a three-phase AC motor will reverse the direction of rotation.

- Reverse any two leads of a three-phase power at the main power source or at connections to motor. **Do not change internal wiring of hoist.**
- After changing two of the main power leads, recheck direction of rotation. Press “UP” button only. If hook travel goes in “UP” direction, proceed to section 3.3. If not, redo section 3.2.

#### 3.3 Operational Checks – No Load

- Check hoist motor brake function. Run empty load block up or down to check that load block does not drift more than 1.0 inch [25mm]. If so, adjust brake as described in Section 5.3 of this manual.
- Run empty load block down to check that fall stop (located on free end of load chain) makes proper contact with upper / lower travel safety limit switch and that limit switch functions properly.
- Run empty load block up to check that load block makes proper contact with upper / lower travel safety limit switch and that limit switch functions properly.
- Run empty load block up and down several times while checking for proper tracking of load chain.

### 3.4 Operational Checks – With Load

- After completion of no-load operational tests, the user /owner should perform a full load test even though each complete hoist is load tested at factory.
- Lift a near capacity load about one (1) foot [30cm] above floor level. Check that the brake holds load. Also, check stopping capability of brake when lifting to a stop and lowering to a stop.
- Move trolley the full length of monorail or crane beam. Check for any binding of trolley wheels on flange and/or interference at splice joints, hanger connections / bolts, etc.
- Check contact with stops. Contact with stops **SHALL** only be made with trolley bumpers. Stops that are designed to make contact with wheels **SHALL NOT** be used.

## 4 HOIST OPERATION



BEFORE PROCEEDING WITH THE NORMAL OPERATION OF THIS HOIST, THE OPERATOR/(S) SHALL BE TRAINED IN ACCORDANCE WITH THE [LoadMate® Electric Chain Hoist Operator's Manual](#) AS SUPPLIED WITH THIS HOIST.

FAILURE TO READ AND COMPLY WITH ANY ONE OF THE LIMITATIONS NOTED IN THIS MANUAL AND THE [LoadMate® Electric Chain Hoist Operator's Manual](#) FURNISHED WITH THIS HOIST CAN RESULT IN PRODUCT FAILURE, SERIOUS BODILY INJURY OR DEATH, AND / OR PROPERTY DAMAGE.

REFER TO SECTION 1.0 OF THIS MANUAL FOR CONTACT INFORMATION IF ADDITIONAL ASSISTANCE IS NEEDED.



® R&M Materials Handling, Inc  
Springfield, Ohio USA  
☎: 800 955-9967  
[www.rmhoist.com](http://www.rmhoist.com)

LoadMate® Chain Hoist  
LM1 Installation & Maintenance Manual

April 2005

---

LEAVE THIS PAGE BLANK

## 5 MAINTENANCE

### 5.1 Basic Hoist Construction

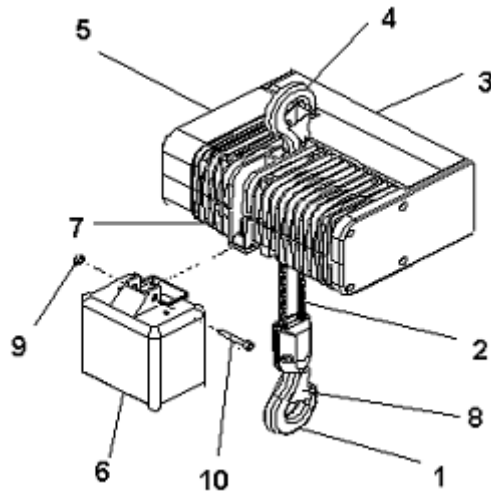

FIGURE 5.1

- 1 - LOAD BLOCK ASSEMBLY (2-FALL SHOWN)
- 2 - LOAD CHAIN
- 3 - ELECTRICAL CONTROL ENCLOSURE
- 4 - TOP HOOK
- 5 - HOIST GEAR BOX ASSEMBLY
- 6 - CHAIN CONTAINER & HARDWARE
- 7 - HOIST BODY / MOTOR
- 8 - LOAD HOOK SAFETY LATCH
- 9 - CLIP (ONE EACH END)
- 10 - PIN

### 5.2 Motor / Body

The hoist motors are designed to provide dependable hoisting service. The standard motors are enclosed for IP55 rated protection against normal hazards of dust and moisture. The motor bearings are sealed and do not require further greasing.

The hoist body is constructed of aluminum and requires no maintenance. Remove from service and replace the hoist body if damaged.



### 5.3 Hoist Motor Brake and Load-Limiting Device

The hoisting motor is equipped with a D.C. electromagnetic disc brake. The brake brings the load to a smooth and quick stop and holds the load when the motor is not energized. An energized coil releases the hoist brake to allow the hoisting motor to run freely when in use.

The load-limiting device is a slip clutch and it is integrated into the design of the hoist motor brake. Even if the clutch slips, once power is removed, the brake will engage to stop and hold the load.

#### 5.3.1 Slip Clutch Operation

When the motor brake is energized, ITEM 5 pulls ITEM 8 away from ITEM 9. ITEM 9 is free to rotate. ITEM 4 applies pressure to ITEM 9 that forces ITEM 9 to engage ITEM 10. The face-to-face contact between ITEMS 9 & 10 creates an adjustable slip clutch between the motor and the load chain sprocket.

As ITEM 2 is tightened, ITEM 4 applies more pressure on the interface between ITEMS 9 & 10. More pressure increases the load capacity of the hoist and less pressure decreases the capacity of the hoist. The ITEM 2 is adjusted to allow the hoist to lift 110 – 125 percent of the rated capacity of the hoist.

In the event that the slip clutch begins to slip during the lifting or lowering process, release the hoist motion control button to stop the motor. This will de-energize the brake. ITEM 8 will now press against ITEMS 9 & 10 to stop rotation and slippage between ITEMS 9 & 10. This will stop and hold the load. Re-adjustment of ITEM 2 will be necessary to eliminate slipping. See section 5.3.2.

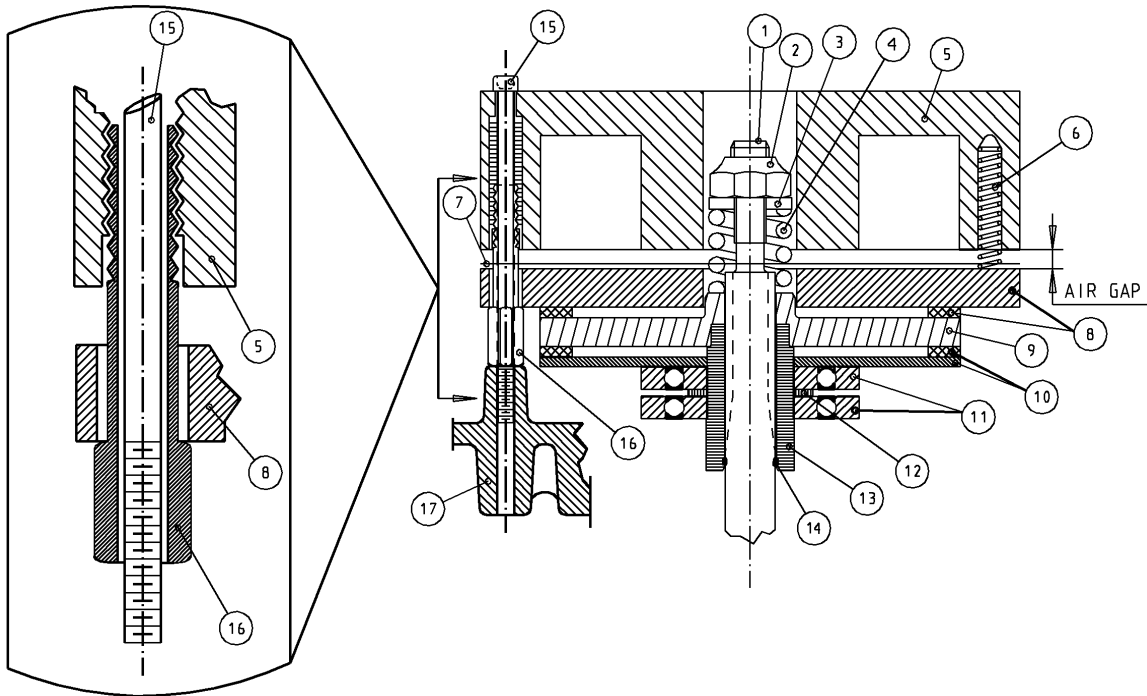

Figure 5.2

ITEM	DESCRIPTION
1	MOTOR SHAFT
2	ADJUSTING NUT
3	WASHER
4	SPRING
5	MAGNET ASSEMBLY
6	SPRING
7	SPACER
8	THRUST DISC
9	ROTOR
10	DISC
11	BEARING
12	BEARING SPACER
13	DRIVE HUB
14	O-RING
15	MOUNTING SCREW
16	ADJUSTING SLEEVE
17	BRAKE HOUSING

A yellow rectangular sign with a black border. On the left is a black triangle containing a white exclamation mark. To the right of the triangle, the word "CAUTION" is written in bold, black, uppercase letters.

## SEE FIGURE 5.2

Make sure the motor is not running before placing tool on the nut to adjust it. Do not touch any moving components.

The slip-clutch generates heat when slipping. ITEMS 9 & 10 absorb this heat. When these items become too hot, clutch adjustment may be difficult due to unstable behavior of friction surfaces. If this happens, allow brake & clutch assembly to cool before trying to re-adjust slip-clutch.

Decreasing torque too much when adjusting slip-clutch will allow a suspended load to free-fall when trying to lift. If this occurs, release the motion button and the brake will engage to stop and hold the load.

### 5.3.2 Slip Clutch Adjustment after Installation

1. Hook a load of at least 110 percent but not more than 125 percent of nameplate capacity.
2. Remove plastic cap from inspection hole in brake cover.
3. Raise load at slow speed and fast speed to test slip clutch operation.
4. Insert a socket (13mm) through inspection hole, and slide it over nut (item 2 - Figure 5.2).  
Turn nut in required direction:
  - Turn nut **clockwise to increase** the torque.
  - Turn nut **counterclockwise to decrease** the torque.
5. Repeat steps 3 and 4 until load can be barely lifted in fast speed. **CAUTION: DO NOT OVERHEAT.** If overheated, clutch may not adjust due to instability of friction surfaces.
6. Once adjustment is completed, install plastic cap.
7. Check function of clutch at 100 percent of nameplate-capacity while in fast speed.

A black rectangular sign with the word "NOTICE" written in white, bold, uppercase letters.

The slip clutch / Torque Limiter is a safety device to prevent overloading of the hoist. This device is not intended for use as means to measure the weight of load being lifted.

### 5.3.3 Hoist Motor Brake Adjustment (See Figure 5.2)

If maximum air gap of brake has been reached or will be exceeded before next inspection, readjust air gap.

Minimum air gap  
 X = 0.006" [ 0.15 mm ]

Maximum air gap  
 X = 0.020" [ 0.5 mm ]

Before adjusting brake, remove load. Per ANSI Z244.1, lockout and tag main disconnect switch in de-energized position. Follow other maintenance procedures outlined in this manual and ASME B30.16.

1. Remove brake cover and gasket.
2. With a feeler gauge, check three (3) places near each mounting bolts, to measure air gap ( X ) between brake thrust disc ( item 8 ) and coil ( item 5 ).
3. To adjust air gap use a 0.008" feeler gauge and proceed as follows:
  - A. Loosen motor brake mounting screws (item 15).
  - B. To **reduce** air gap, tighten three adjusting sleeves (item 16).
  - C. To **increase** air gap, loosen three adjusting sleeves (item 16).  
 Repeat step "A" until air gap is snug against feeler gauge and is measures the same in three places.
4. Check brake operation. Run load block up and down several times without a load to test operation of brake. Then, lift a capacity load about one foot above floor, stop, and check that brake holds load.
5. Install gasket and brake cover.

## 5.4 Load Chain

### 5.4.1 General



**A hoist SHALL NEVER be used if the load chain shows any evidence of mechanical damage or excessive wear. Never use the load chain as a sling. Use only original equipment chain as supplied by a factory authorized source. Improper load chain storage or installation can render the load chain unusable prior to the first lift.**

### 5.4.2 Maintenance Inspection

A qualified person **SHALL** be designated to routinely conduct an in-depth inspection of the load chain (See Section 6 – Preventative Maintenance for schedule recommendations). This designated person **SHALL** inspect load chain using good judgment in evaluating the remaining service life. Any deterioration of load chain resulting in appreciable loss of original strength **SHALL** be noted and evaluated.

An in-depth inspection **SHALL** include a written record that is dated and signed by the inspector.

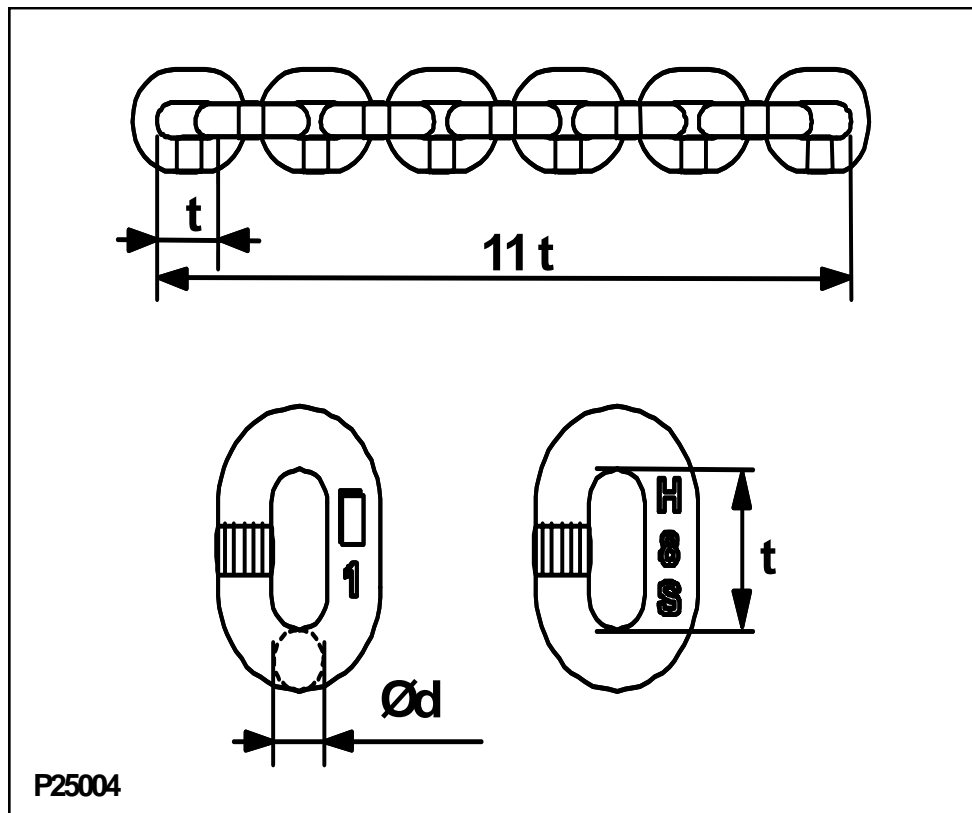

Figure 5.3

Measure the following chain dimensions at several points on chain: ( Figure 5.3 )

- Dimensions of one link (  $d \times t$  ) where,  $d$  = diameter and  $t$  = pitch
- Length over 11 links (  $11 t$  )

Replace load chain if any one of these dimensions exceed maximum allowed wear.

Maximum allowed wear:

Minimum link diameter allowed ( $d$ ):	0.1102" [2.8 mm]
Maximum pitch allowed ( $t$ ):	0.3839" [9.75 mm]
Maximum length allowed ( $11t$ ):	4.1063" [104.3 mm]

**NOTICE**

If load chain needs replaced, then inspect chain guide and chain (load) wheel on hoist and idler sprocket in 2-fall load block for excessive wear. A chain sprocket showing evidence of scored pockets or sharp edges generated from wear SHALL be replaced. A worn chain sprocket or idler sprocket can greatly reduce the life of load chain.



### 5.4.3 Load Chain Specifications (see Figure 5.3)

Chain use:	Load chain
Chain type:	Standard - Galvanized
Size: (d) diameter x (t) pitch:	0.122" [3.1 mm] / 0.366" [9.3 mm]
Class:	DAT
Grade:	H8S or HE G80 RAS
Maximum working stress:	14,516.1 lbs / in <sup>2</sup> [100 N / mm <sup>2</sup> ]
Hardened surface:	580 to 700 HV [Vickers Hardness]
Thickness:	0.0039" [0.1 mm] to 0.0079" [0.2 mm]
Standard:	DIN 5684
Marking ( 10 x t ):	1 or 16 H 8 S or A 8
Maximum working load, 1-fall:	275 lbs. [125 kg]
Breaking load:	2520 lbs [11.2 kN]
Maximum breaking stress:	116,030 lbs / in <sup>2</sup> [800 N/mm <sup>2</sup> ]
Total breaking elongation:	>10% min.
Weight per foot [meter]:	0.148 lbs. [0.22 kg]

### 5.4.4 Removing the Load Chain

#### 1-FALL CHAIN

1. Remove load from hook block assembly.
2. Remove load block assembly from load chain. Some disassembly of 1-fall load block is required.
3. Attach the chain insert tool to the end of bottom block end of the chain.
4. Run hoist in "UP" direction until all of chain is in container. Stop the hoist with the insertion tool remaining in the hoist ready for the new chain.
5. Remove chain container with all of old chain in chain container.
6. Remove fall stop from old chain and save for use with new chain.

#### 2-FALL CHAIN

1. Remove load from hook block assembly.
2. Run hoist in "UP" direction until hook block assembly is about 1.0 foot [30cm] from hoist body.
3. Unfasten load chain from chain anchor mounted on hoist body.
4. Remove load block assembly from load chain by allowing chain to run through it. Attach the chain insertion tool to the bottom block end of the chain.
5. Run hoist in "UP" direction until all of the chain is in the container. Stop the hoist with the insertion tool remaining in the hoist ready for the new chain.
6. Remove chain container with old chain.
7. Remove fall stop from old chain and save for use with new chain.

### 5.4.5 Installing the Load Chain

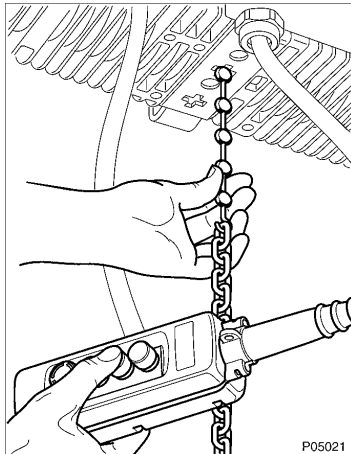

Figure 5.4

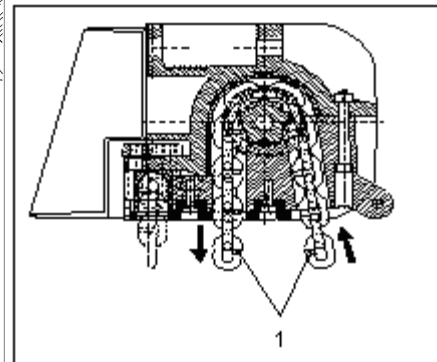
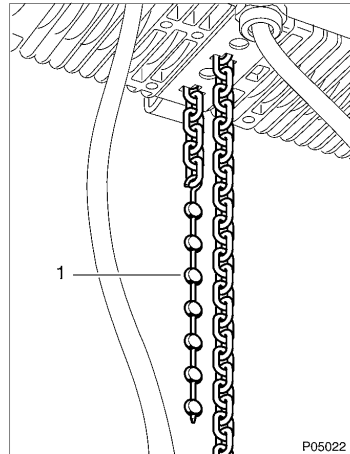

Figure 5.5

#### 1-FALL CHAIN INSTALLATION

1. Attach last link of chain onto hook of CHAIN INSERTION TOOL (item 1, Figure 5.4).
2. If the insertion tool is not in the hoist (removal procedure), insert other end of CHAIN INSERTION TOOL into chain opening closest to chain container side.



**Make sure the chain weld on chain link faces inward toward chain wheel pocket on hoist load sprocket. See Figure 5.5.**

3. Run hoist "UP" in slow speed to feed chain through chain sprocket and out other side.
4. Attach fall stop at least 6.0 inches [150 mm] from end of chain (chain container side). Attach load block assembly on other end of load chain. Refer to Figure 5.6 for details.
5. Make sure that load chain is not twisted or deformed.
6. Attach chain container.

#### 2-FALL CHAIN INSTALLATION

1. If the chain insertion tool is not in the hoist (removal procedure), attach last link of chain onto hook of CHAIN INSERTION TOOL (item 1, Figure 5.4).
2. Insert other end of CHAIN INSERTION TOOL into chain opening closest to chain container.



**For a 2-Fall load block assembly, make sure the chain weld on chain link faces inward toward chain wheel pocket on hoist and away from idler sprocket of hook block assembly. See figure 5.5. Follow steps outlined below:**

3. Run hoist in slow speed to feed chain through chain sprocket. Continue running until about 2.0 feet [60cm] of chain is available out the other side.
4. Slide chain onto idler sprocket of load block making sure not to twist chain while inserting it. Link weld must face away from idler sprocket on load block assembly.
5. Attach chain anchor and chain to hoist body. Tighten chain anchor bolts per recommended torque settings in Section 6.4.
6. Attach fall stop 6.0 inches [150 mm] from end of chain (chain container side). See Figure 5.6 for details.
7. Make sure that chain is not twisted or kinked.
8. Attach chain container.

After chain installation:

1. Without a load, run chain up and down a few times to make sure load chain is not twisted. If so, remove chain twist.
2. Lubricate load chain.

## 5.5 Fall Stop Assembly

### 5.5.1 General

The slack fall stop is a safety stop, not a functional stop. The fall stop must be located at least six (6.0) inches [150mm] from end of last chain link.

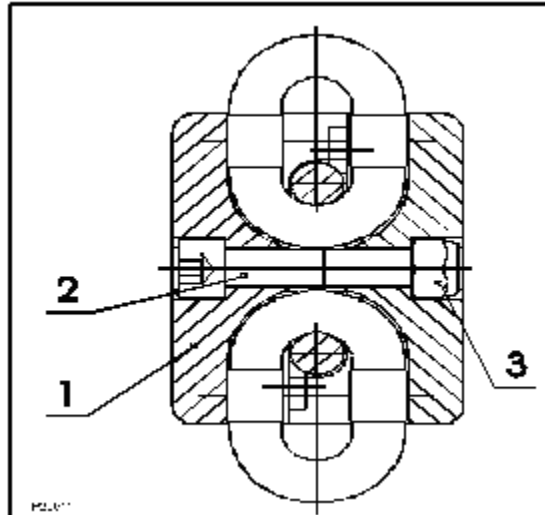

FIGURE 5.6

### 5.5.2 Fall Stop Installation

1. Position two fall stop halves (item 1, Figure 5.6) on chain link at least six (6.0") inches [150mm] from end of load chain.
2. Insert screw (item 2) through fall stop halves and chain link.
3. Tighten nut (item 3) per torque setting in section 6.4.

## 5.6 Chain Container

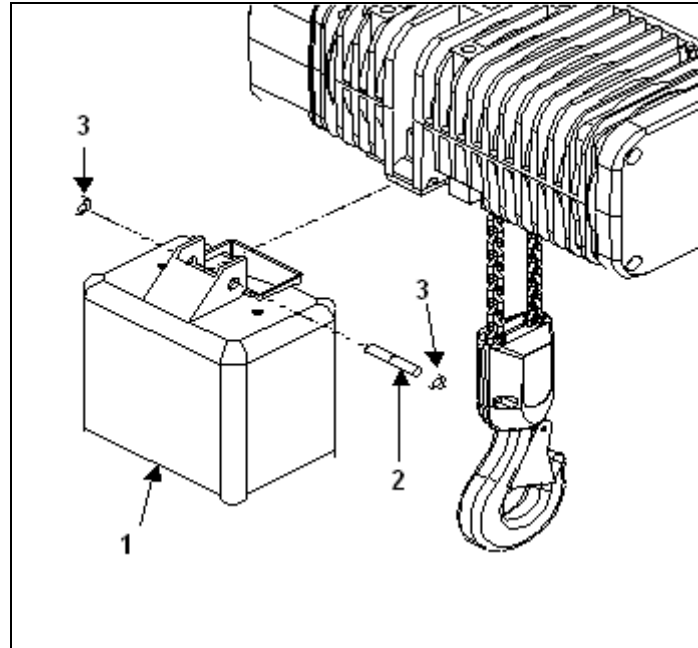

Figure 5.7



**Chain container must be in installed for effective operation of travel limit switch.**

### Removing Chain Container

1. Remove clip (item 3) from end of pin (item 2).
2. Pull pin (item 2) out while supporting chain container (item 1) at same time.
3. Remove chain container.

### Installing Chain Container

1. Insert load chain into chain container (item 1) and position chain container on mounting bracket.
2. Align holes and insert pin (item 2) through chain container (item 1) and mounting bracket.
3. Secure with two clips (item 3), one on each end of pin (item 1).

## 5.7 Limit Switches

### 5.7.1 Upper and Lower Travel Safety Limit Switch

The Upper and Lower Travel Limit Switch is an automatic reset type switch and connected to the control circuit. The switch housing is recessed into the underside of hoist body.

The upper and lower limit switches are emergency protection devices and are not to be used as a continuous stop.

The hook block activates the upper limit switch as it contacts the limit switch that is located on bottom side of hoist body. Once the switch is activated, the “UP” circuit is opened. The fall stop activates the lower limit switch when hook block is lowered to its lowest travel position. The limit switch is activated and opens the “down” circuit.

The lower limit position is adjustable between the lowest travel and maximum lift. It is adjusted by repositioning the fall stop assembly on free end of load chain. The fall stop **SHALL** always be located at least 6 inches [150mm] from end of last chain link. The upper limit position is adjustable only when an additional fall stop assembly is added between the hook block assembly and the hoist body.

### 5.7.2 Upper and Lower Rotary Travel Limit Switch (Optional Only on 3-Phase units)

The rotary limit switch is adjustable and provides over-travel protection for the upper and lower limits of hoist travel. The limit switch is connected to the control circuit.

**Note: Not available on Single Phase – 115 Volt Models**

**Note: Rotary limit switch assembly cannot be added to a Hoist. The Hoist must have the rotary limit switch assembly provided at time of initial production.**

#### Adjustment

The position of the air-gap between the two discs (red – gray) determines the stopping place. This position can be found by gently turning the two discs. The length of air gap determines length of reset play in opposite direction.

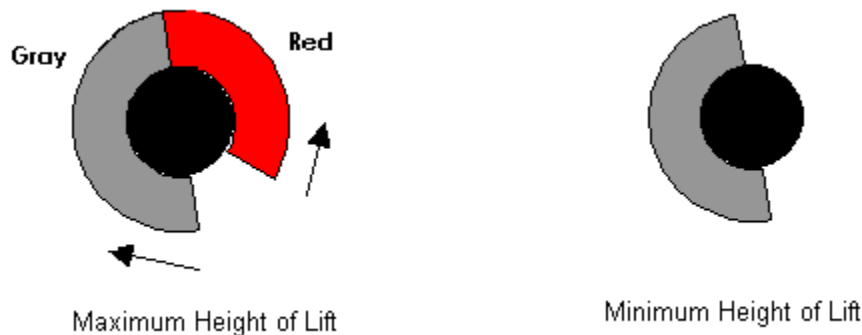

To reset the rotary limit once it has tripped, the load block assembly must travel approximately 11” [27cm] in opposite direction.

## 5.8 Hooks

### 5.8.1 General

Check hooks for deformation or cracks. Hooks must be replaced if throat opening has increased by more than 15%, or if throat opening has more than 10-degree twist from plane of straight hook.

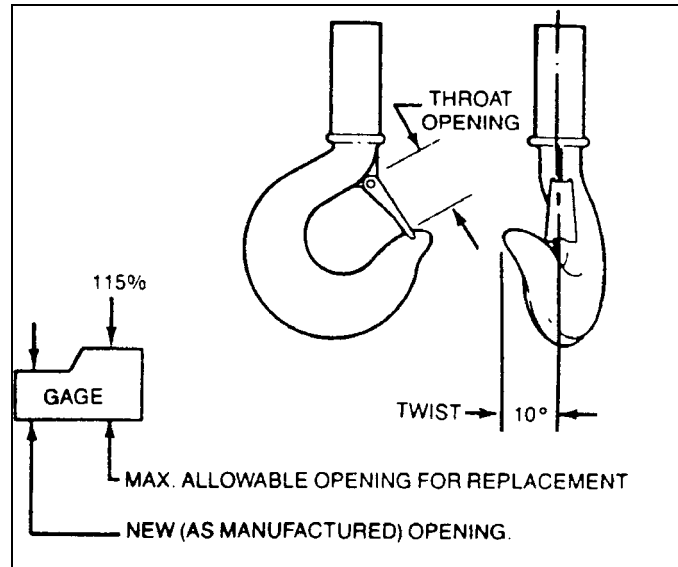

Figure 5.9

Due to many types and sizes of hooks that can be furnished and/or specified by the user / owner, it is recommended that user / owner measure the actual throat opening of hook as originally furnished. See Figure 5.9. Record the throat dimension on above sketch. Retain as a permanent record. This record can then be used for determining when hook must be replaced due to deformation or excessive throat opening.

## **CAUTION**

Abuse or overloading of hoist is indicated when any hook is twisted or has a throat opening in excess of normal. Other load bearing components **SHALL** be checked for damage.

Safety latches **SHALL** be replaced if missing, bent, or broken.

A safety latch **SHALL** function properly at all times.

Repairing hooks by welding or reshaping is strictly forbidden.

### 5.8.2 Inspection

Inspection for wear on top hook and load hook **SHALL** be checked routinely. Measure the throat opening. (dimension-a2). If throat opening exceeds maximum opening allowed, replace hook. Damaged safety latches **SHALL** be replaced immediately.

Maximum throat opening allowed:

Hook Class:	012P load hook	top hook
Maximum opening allowed:	0.906" [23 mm]	0.906" [23 mm]

### 5.8.3 Hook Dimensions and Specifications

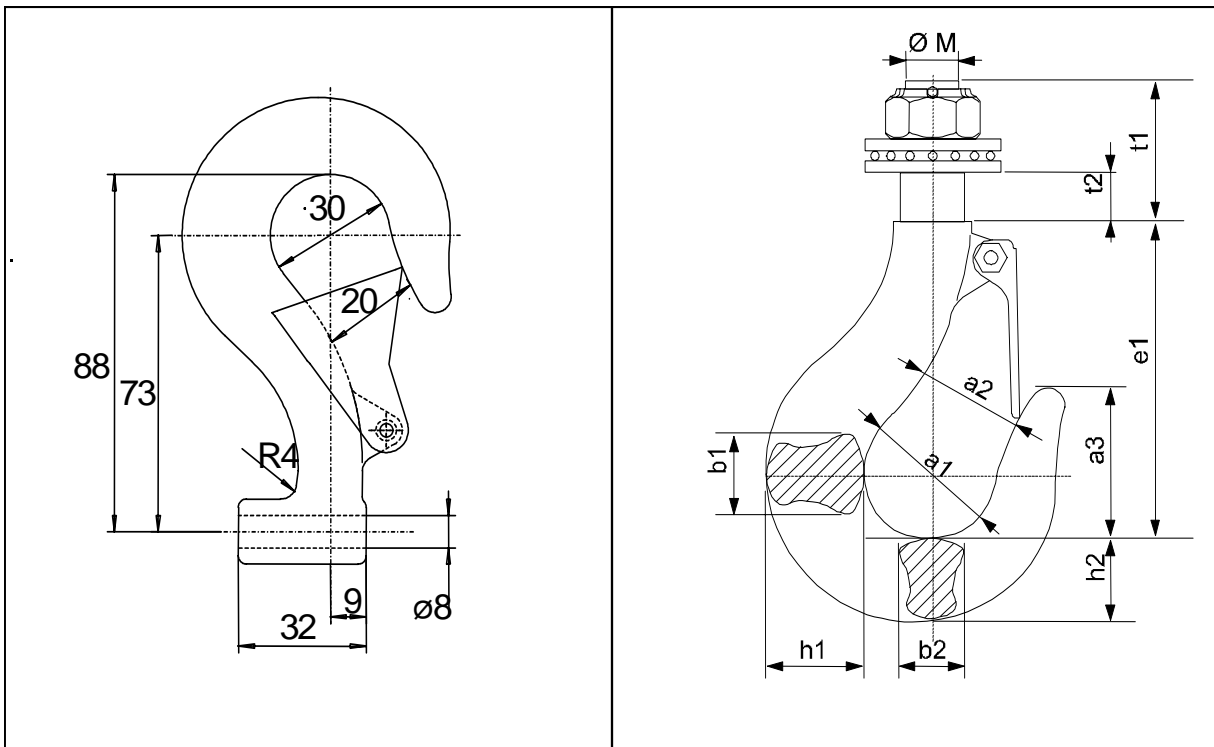

Figure 5.10

SPECIFICATIONS				
CAP tons	CAP kg	TEST kg	FALLS	HOOK CLASS
1/8	125	1102	1	012P
1/4	250	1102	2	012P

HOOK DIMENSIONS											
	Ø M	Ø a1	a2	a3	b1	b2	e1	h1	h2	t1	t2
Inches	0.551	1.181	0.787	1.339	0.748	0.591	3.268	0.866	0.748	1.260	0.394
mm	14	30	20	34	19	15	83	22	19	32	10

Mark: ISO 2766  
DIN 15400 class: T

DIN model number: 15401  
DIN 15401 material: 35 CD 4

#### 5.8.4 Top Hook

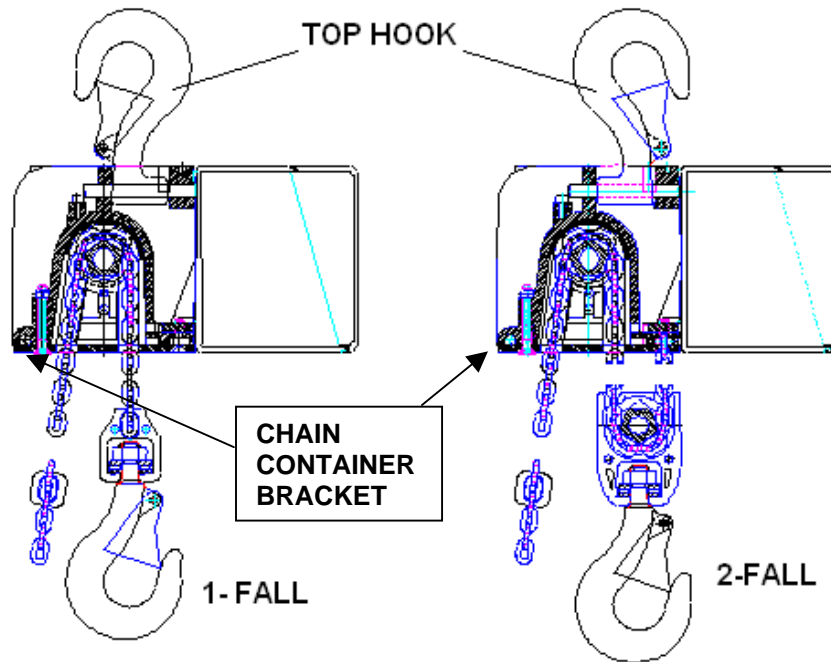

Figure 5.11

**⚠ CAUTION**

Before removing Top Hook, de-energize the power to the hoist per ANSI Z244.1 and make certain that any load is removed from the load hook. Also support the total weight of the hoist, including chain, prior to removing the Top Hook.

#### Removing Top Hook

1. Remove locking plate and pin.
2. Pull pin out and remove hook.

**⚠ CAUTION**

**Proper installation of top hook is critical for hoist balance.**

#### Installing Top Hook

1. Determine number of chain falls: 1-fall or 2-fall.
2. Select proper placement of top hook relative to number of chain falls:
  - If 1-fall, align top hook so that tip of hook faces toward chain container.
  - If 2-fall, align top hook so that tip of hook faces away from chain container.



- Place hook into the slot on hoist body. Verify that top hook saddle and load hook saddle are in line with each other. Install locking plate and pin.

## 5.9 Controls

### 5.9.1 General

Three-phase, two-speed hoists are available for most three-phase power supply voltages. The controls of two-speed hoists **cannot** be connected to more than one power supply voltage.

The control panel layouts and wiring diagrams found in this manual are for standard hoist controls. The hoist motor brake rectifier is part of the PC (printed circuit) board assembly.

### 5.9.2 Control Fuses

The control fuse for Three-Phase control panels is located in a vertical, cylindrical fuse holder labeled F100. This is mounted to the printed circuit board. The top rotates loose for replacement. See Section 5.10 for location.

The control fuse for the Single-Phase 115V control panels is installed as an in-line fuse holder on a wire. The in-line housing separates for replacement. See Section 5.14 wiring diagrams for wire location.

POWER SUPPLY	CONTROL VOLTAGE	FUSE SIZE
3 – PHASE	115 VAC	500 mA
3 – PHASE	48 VAC	630 mA
1 - PHASE	115 VAC	250 mA

5.10 Control Panel Layout – Three Phase – Two Speed

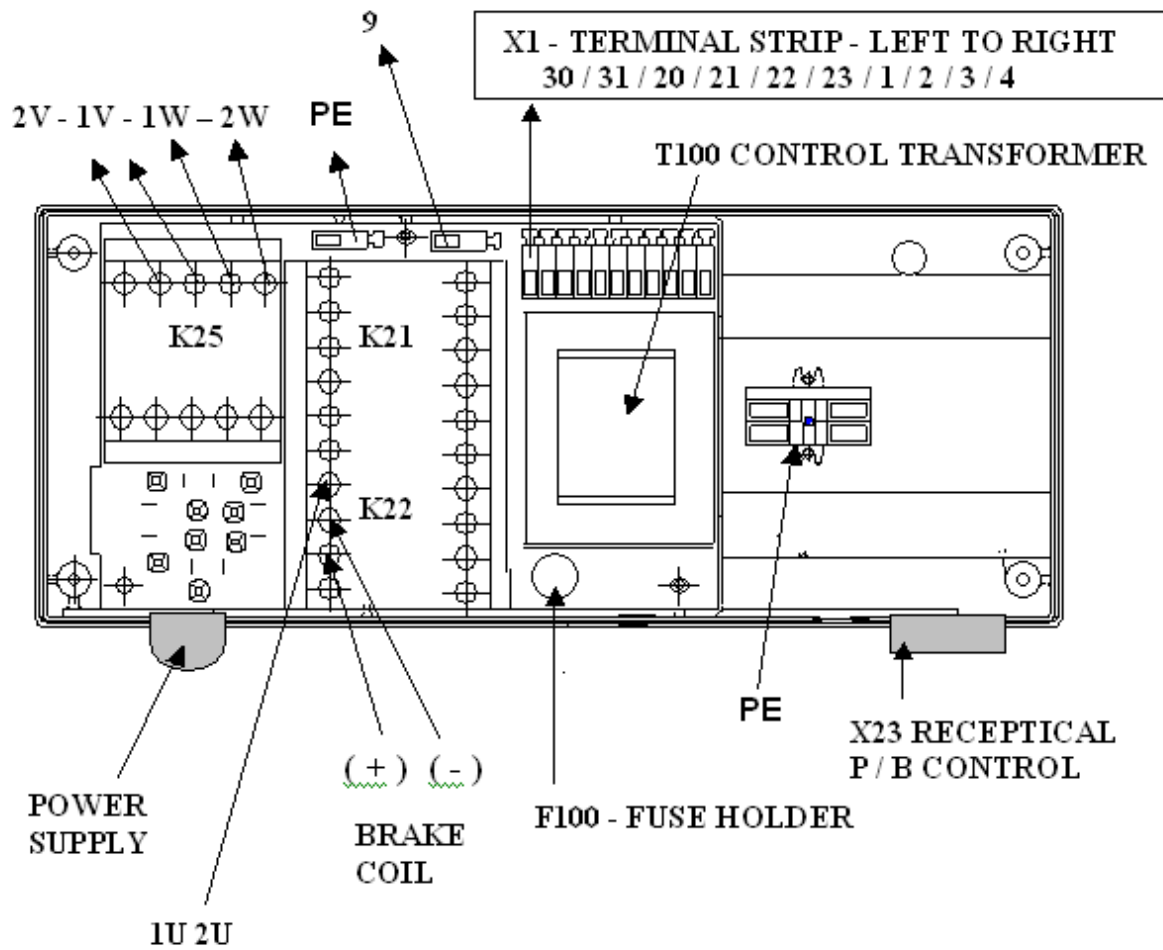
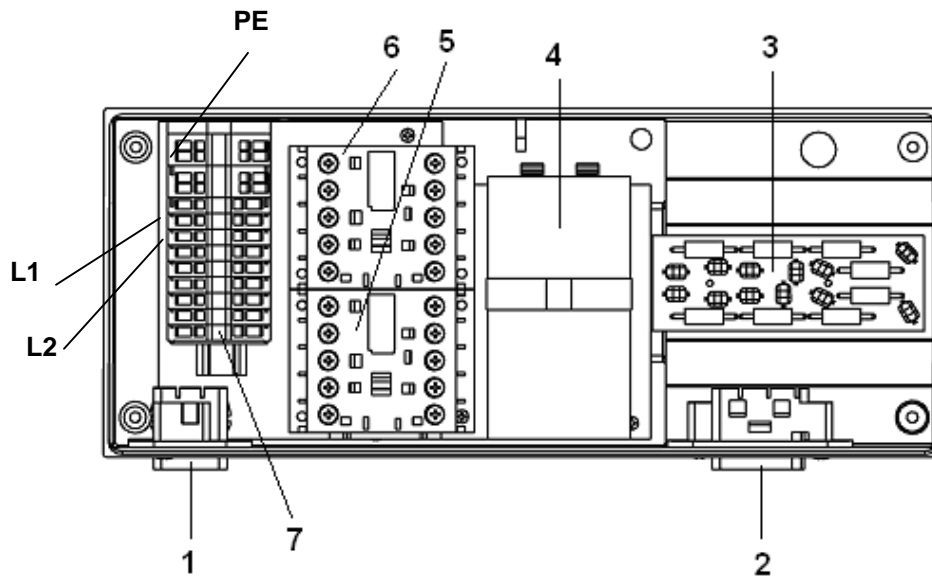

FIGURE 5.12

5.11 Control Panel Layout – Single Phase – Single Speed – 115 Volt



1. Power Supply Gland (Plug Connection Optional)
2. Pushbutton plug connection
3. Motor Brake Rectifier Control Board
4. Motor Capacitor
5. Direction Contactor
6. Direction Contactor
7. Terminal Strip
8. PE = Ground

FIGURE 5.13

### 5.12 Wiring Diagram – Three Phase – Two-speed Hoist

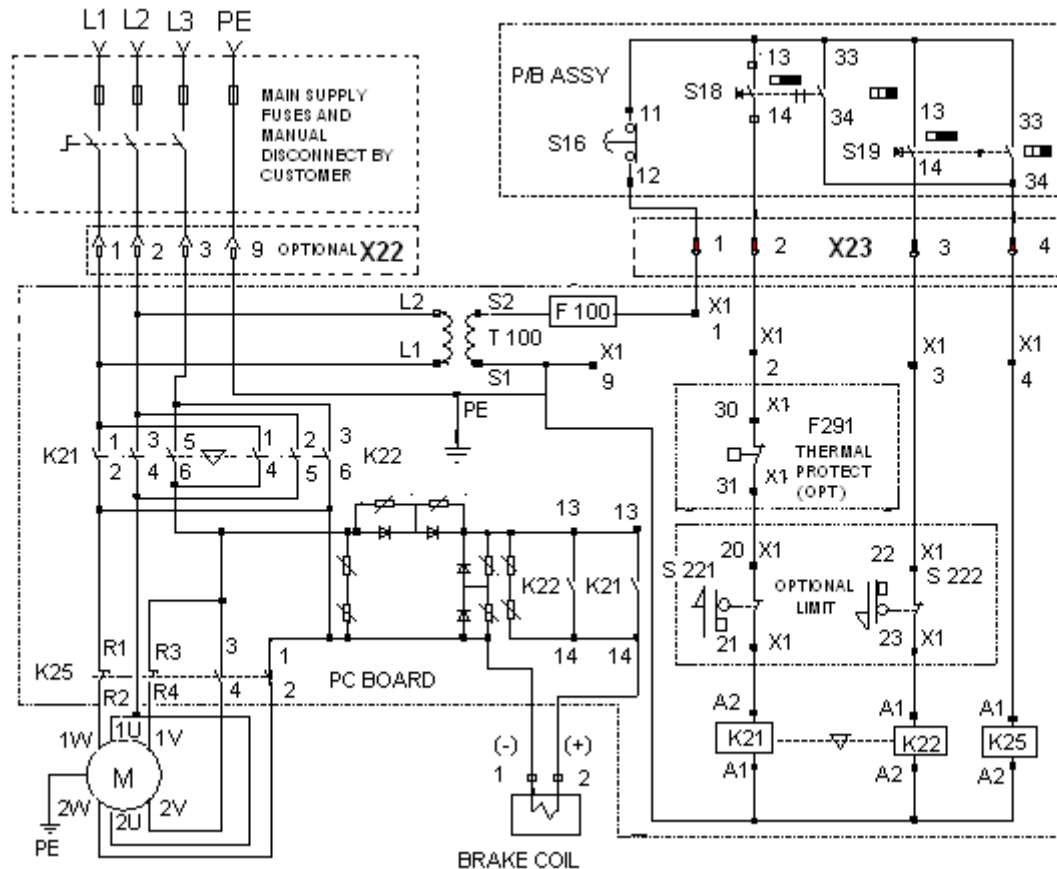

#### 3 PHASE POWER SUPPLY CONNECTIONS

L1 HOIST SUPPLY – PHASE A  
L2 HOIST SUPPLY – PHASE B  
L3 HOIST SUPPLY – PHASE C  
(-) HOIST MOTOR BRAKE SUPPLY – VDC  
(+) HOIST MOTOR BRAKE SUPPLY – VDC

1V MOTOR SUPPLY – SLOW SPEED  
2V MOTOR SUPPLY – FAST SPEED  
1W MOTOR SUPPLY – SLOW SPEED  
2W MOTOR SUPPLY – FAST SPEED

1U2U MOTOR SUPPLY – SLOW AND FAST SPEEDS

#### PLUG X23 – P/B CONTROL

1 - CONTROL VOLTAGE SUPPLY  
2 - HOIST UP  
3 - HOIST DOWN  
4 - HOIST FAST  
9 - GROUND

#### TERMINAL STRIP X1 NUMBERS

30 - MOTOR THERMAL PROTECTION  
31 - MOTOR THERMAL PROTECTION  
22 - UPPER LIMIT SWITCH  
23 - LOWER LIMIT SWITCH

K21 - HOIST "UP" CONTACTOR  
K22 - HOIST "DOWN" CONTACTOR  
K25 - HOIST "FAST" CONTACTOR  
F100 - CONTROL CIRCUIT FUSE

- 1 - CONTROL VOLTAGE SUPPLY
- 2 - HOIST UP
- 3 - HOIST DOWN
- 4 - HOIST FAST
- 9 - GROUND

**5.13 Wiring Diagram – Three Phase – Pushbutton**

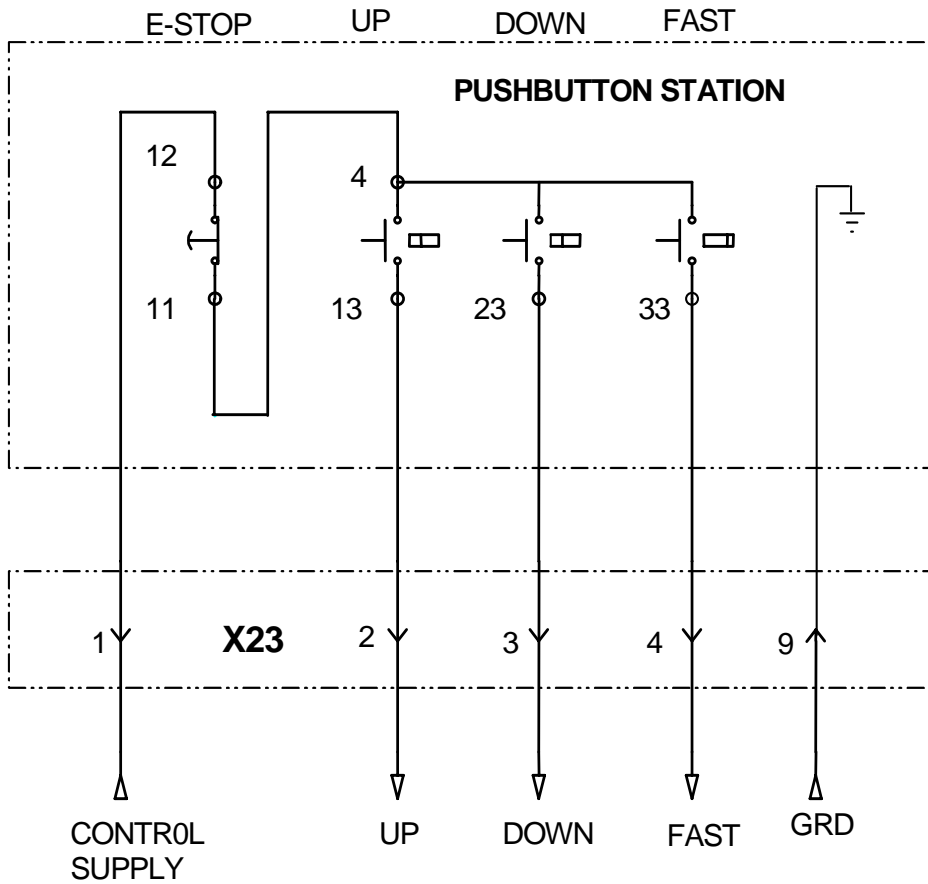



## 5.14 Wiring Diagram– Single Phase – Connections and Components

### Connections, Terminals, and Components for Single Phase

L1 – SINGLE PHASE POWER SUPPLY  
L2 – SINGLE PHASE NEUTRAL  
PE – GROUND  
- – MOTOR BRAKE SUPPLY  
+ – MOTOR BRAKE SUPPLY  
U1V1 – MOTOR SUPPLY  
U2 – MOTOR “UP”  
V2 – MOTOR “DOWN”  
X23 – PUSHBUTTON CONTROL ASSEMBLY PLUG  
X22 – OPTIONAL POWER SUPPLY PLUG

**NOTE: ROTARY LIMIT SWITCH IS NOT AVAILABLE FOR SINGLE PHASE UNITS.**

5.15 Wiring Diagram – Single Phase – Power Circuit

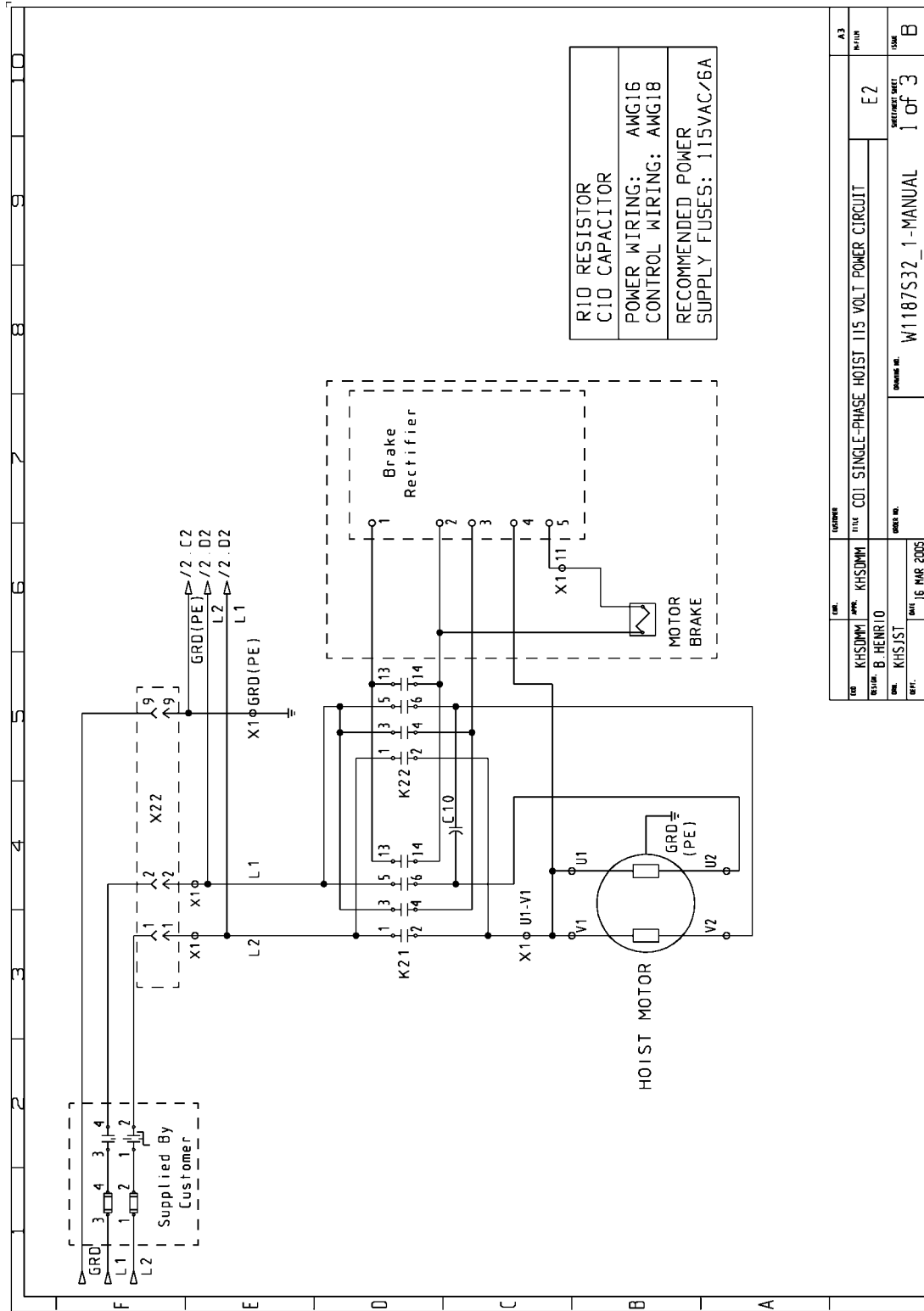

5.16 Wiring Diagram – Single Phase – Control Circuit

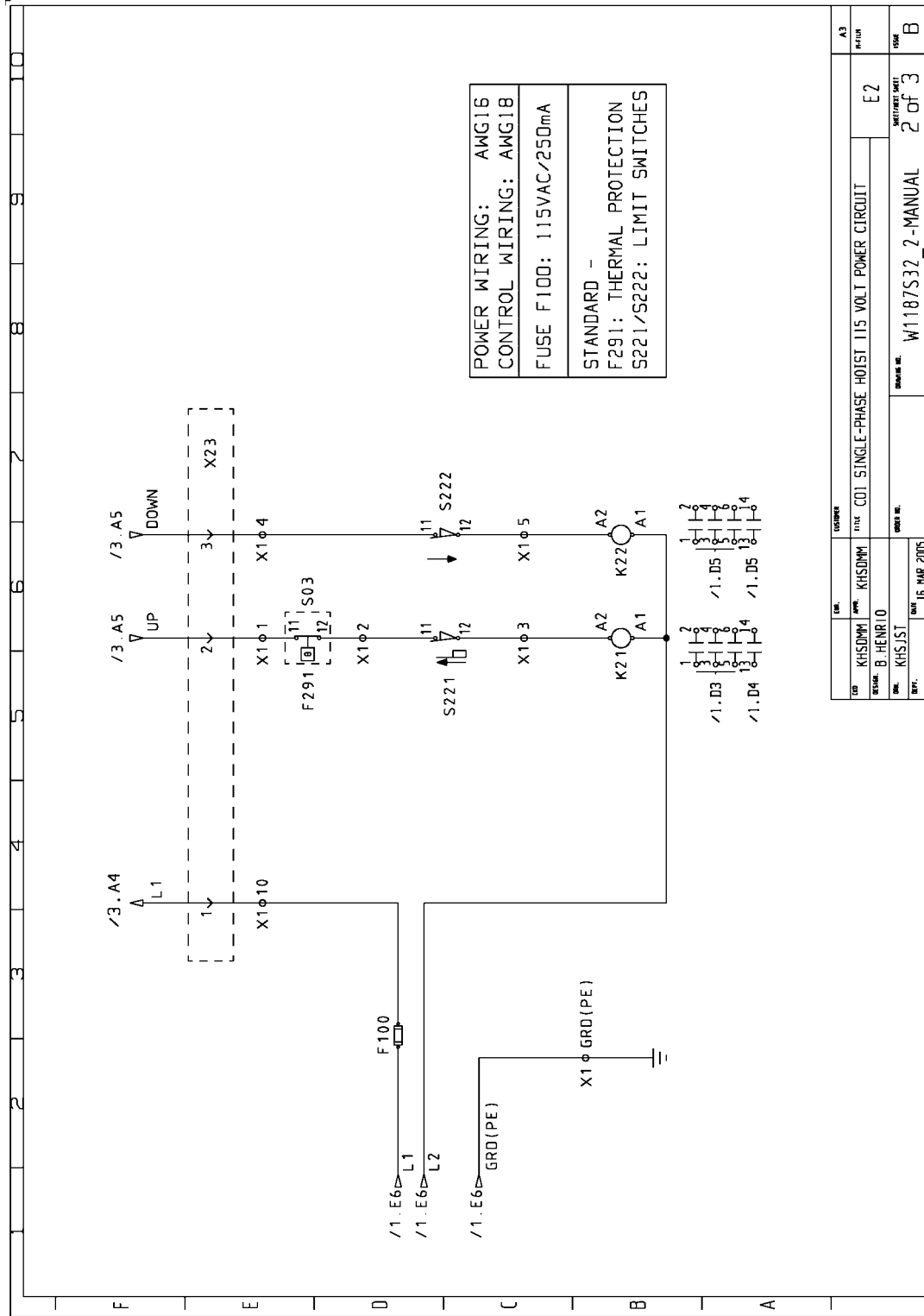





® R&M Materials Handling, Inc  
Springfield, Ohio USA  
☎: 800 955-9967  
[www.rmhoist.com](http://www.rmhoist.com)

LoadMate® Chain Hoist  
LM1 Installation & Maintenance Manual

April 2005

---

LEAVE THIS PAGE BLANK

## 6 PREVENTATIVE MAINTENANCE

### 6.1 Maintenance and Inspection Table

INSPECTION CHECK	INTERVAL	QUALIFIED PERSON
BRAKE OPERATION FOR HOLDING AND RELEASING	DAILY	OPERATOR
LOAD CHAIN FOR DAMAGE	DAILY	OPERATOR
SUSPENSION SUPPORT OF P/ B ASSEMBLY	DAILY	OPERATOR
CLEANLINESS & LUBRICATON OF LOAD CHAIN	MONTHLY	OPERATOR
UPPER / LOWER LIMIT SWITCHS	MONTHLY	OPERATOR
CHECK LOAD CHAIN FOR WEAR – MEASURE AND RECORD	QUARTERLY	INSPECTOR
CHECK HOOKS FOR WEAR MEASURE AND RECORD	QUARTERLY	INSPECTOR
CHECK LOAD BLOCK HARDWARE TO VERIFY TIGHTNESS	QUARTERLY	OPERATOR
CHECK TOP HOOK / COUPLING HARDWARE FOR TIGHTNESS	QUARTERLY	OPERATOR
CHECK SLIP CLUTCH & HOIST BRAKE ADJUSTMENT	QUARTERLY	MAINTENANCE
CHECK LUBRICATION OF OPEN WHEEL GEARING	QUARTERLY	MAINTENANCE
CHECK WIRE TERMINALS TIGHTNESS	SEMI-ANNUALLY	MAINTENANCE
LUBRICATE 2-FALL LOAD BLOCK SPROCKET	ANNUALLY	OPERATOR
CHECK ALL HARDWARE FOR TIGHTNESS AND CORROSION	ANNUALLY	MAINTENANCE
CLEAN MOTOR COOLING FINS	ANNUALLY	MAINTENANCE
LUBRICATE ALL GEARING	ANNUALLY	MAINTENANCE
INSPECT LOAD BLOCK THRUST BEARING	ANNUALLY	MAINTENANCE



INSPECTION AND MAINTENANCE INTERVALS SHOULD BE ADJUSTED BASED UPON OWNER / USER KNOWLEDGE OF APPLICATI ON, ENVIRONMENT, AND FREQUENCY OF USE TO PREVENT DAMAGE TO PEOPLE, EQUIPMENT, AND FACILITIES.

## 6.2 Lubrication

LUBRICATION POINT / QTY	SPECIFICATIONS	POSSIBLE BRANDS
■ AS REQUIRED	Oil or liquid grease	Chain lubricant (Ceplattyn or similar) EP-90
▲ AS REQUIRED	GREASE (without MoS2) KP 2 (DIN 51 502) Soap-based lithium Temperature -4°F to 266°F	BP Energrease LS - EP 2 ESSO Unirex N2 Mobil grease HP Shell Alvanio EP Grease 2
● 0.05 LITER	KP 0 K grease (DIN 51502) Soap-based lithium + MoS2 Temperature -30°C to 130°C	Mobil grease special BP Multi-purpose grease L 21 M Shell Retimax AM Texaco Molytex grease EP 2

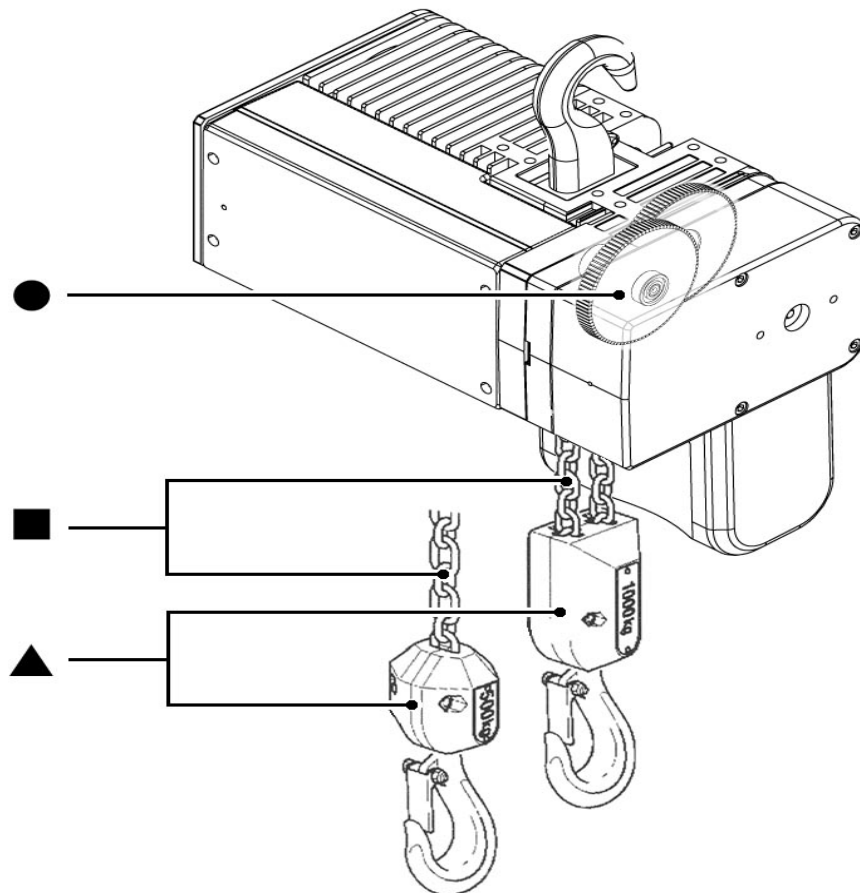

**OPEN WHEEL GEARING: MOBILUX EP1 OR EQUIVALENT**



### 6.3 Recommended technical support for various spare parts

SPARE PART	REPLACED BY
Upper chain guide	Qualified Electrician & Mechanic
Output shaft	Qualified Electrician & Mechanic
PG cable gland	Qualified Electrician
Gear shaft + nuts	Qualified Mechanic
Motor end cap	Qualified Mechanic
Gearing (1st/2nd stage)	Qualified Electrician & Mechanic
Brake & end cap sealing	Qualified Mechanic
Other seals and O-rings	Qualified Mechanic
Brake-limiter	Qualified Electrician
Brake end cap	Qualified Mechanic
Lower chain guide	Qualified Mechanic
Rubber buffer	Qualified Mechanic
Electric box	Qualified Electrician
PC-board	Qualified Electrician
Plugs	Qualified Electrician
Chain	Qualified Mechanic
Chain bucket	Qualified Mechanic
Slack fall stop	Qualified Mechanic
Suspension hook	Qualified Mechanic
Hook block assembly	Qualified Mechanic
Control box	Qualified Electrician

Once a part has been replaced, perform an operational check of hoist per Sections 3.3 and 3.4.

### 6.4 Screw Tightening Torque (lb-ft) Specifications

	M5	M6	M8	M10	M12
STANDARD SCREWS	4	7	18	35	61
SELF-TAPING SCREWS	4	6	15	30	53

## 6.5 Troubleshooting

PROBLEM	POSSIBLE CAUSE	POSSIBLE SOLUTION
Hoist does not lift or lower load	Emergency stop button is activated	Deactivate button
	Blown fuse	Replace the fuse
	Motor thermal protection activated	Allow motor to cool down
	Pendant plug pin pushed out	Reinstall plug pin
	Contactora terminal screws loose	Tighten screws
	Mainline switch shut off	Turn switch on
Hoist does not lift load	Overload condition	Reduce load
	Slip clutch worn or incorrectly adjusted	Replace wear items or readjust slip clutch torque
	Brake not releasing	Check brake coil resistance. Check air gap setting. Adjust if necessary. Check rectifier output voltage.
Load drifts more than 4 inches [100mm]	Brake lining worn Air gap on brake is too wide	Replace wear items as necessary Adjust air gap setting
Travel direction does not correspond to that indicated on push button	Power supply incorrectly connected	See SECTION 2
Abnormal noises while lifting or lowering	Load chain and its components are not lubricated	Clean and lubricate load chain.
	Load chain is worn	Replace chain
	Chain wheel or chain guide is worn	Replace chain wheel or chain guide
	Idler sprocket is worn	Replace idler sprocket
	A supply phase is missing	Connect the three phases
	Twist or kink in load chain	Remove twist or kink



LEAVE THIS PAGE BLANK

## 7 PARTS ILLUSTRATION

### 7.1 Hoist Body

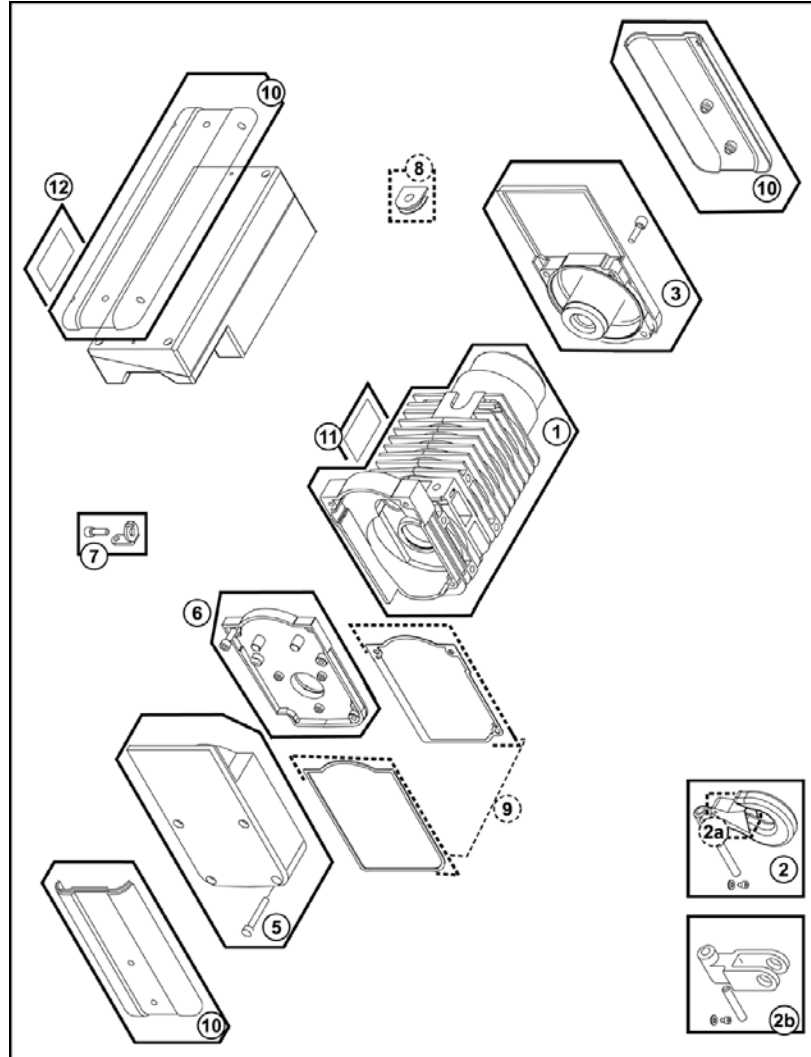



ITEM	PART NUMBER	DESCRIPTION	QTY PER
	52292290	TWO SPEED BODY & CONTROLS: 208/230V – 3 PHASE	1
	52292289	TWO SPEED BODY & CONTROLS: 460V – 3 PHASE	1
	52292291	TWO SPEED BODY & CONTROLS: 575V – 3 PHASE	1
	52315417	SINGLE SPEED BODY & CONTROLS: 115V – 1 PHASE	1
1	N/A	MACHINED HOIST BODY WITH STATOR	1
2	2218060	TOP HOOK SET	1
2a	2212016	TOP HOOK SAFETY LATCH – STEEL PLATE TYPE	1
2b	2218061	COUPLING SET	1
3	2218055	MOTOR END CAP ASSEMBLY	1
5	2218056	BRAKE COVER SET	1
6	2218057	GEAR COVER / FLANGE ASSEMBLY	
7	2218000	PUSH BUTTON ANCHOR BRACKET ASSEMBLY	1
8	2218004	POWER CABLE GUIDE	1
9	2218058	GASKET SET	1
10	<a href="#">2406879007</a>	<a href="#">LM1 BRANDING SET</a>	<a href="#">1</a>
12a	2213309005	BODY CAPACITY STICKER - 1/8 TON	1
12b	2213309001	BODY CAPACITY STICKER - 1/4 TON	1
12c	2213309018	BODY CAPACITY STICKER - 125 KG	1
12d	2213309007	BODY CAPACITY STICKER – 250 KG	1
-	2213445002	ELECTRICAL HAZARD WARNING SIGN	1
-	2213445001	ELECTRICAL WIRING INFORMATION LABEL	1
-	52296703	2-FALL WARNING LABEL (2-FALL ONLY)	1

## 7.2 Helical Gear Mechanism & Brake

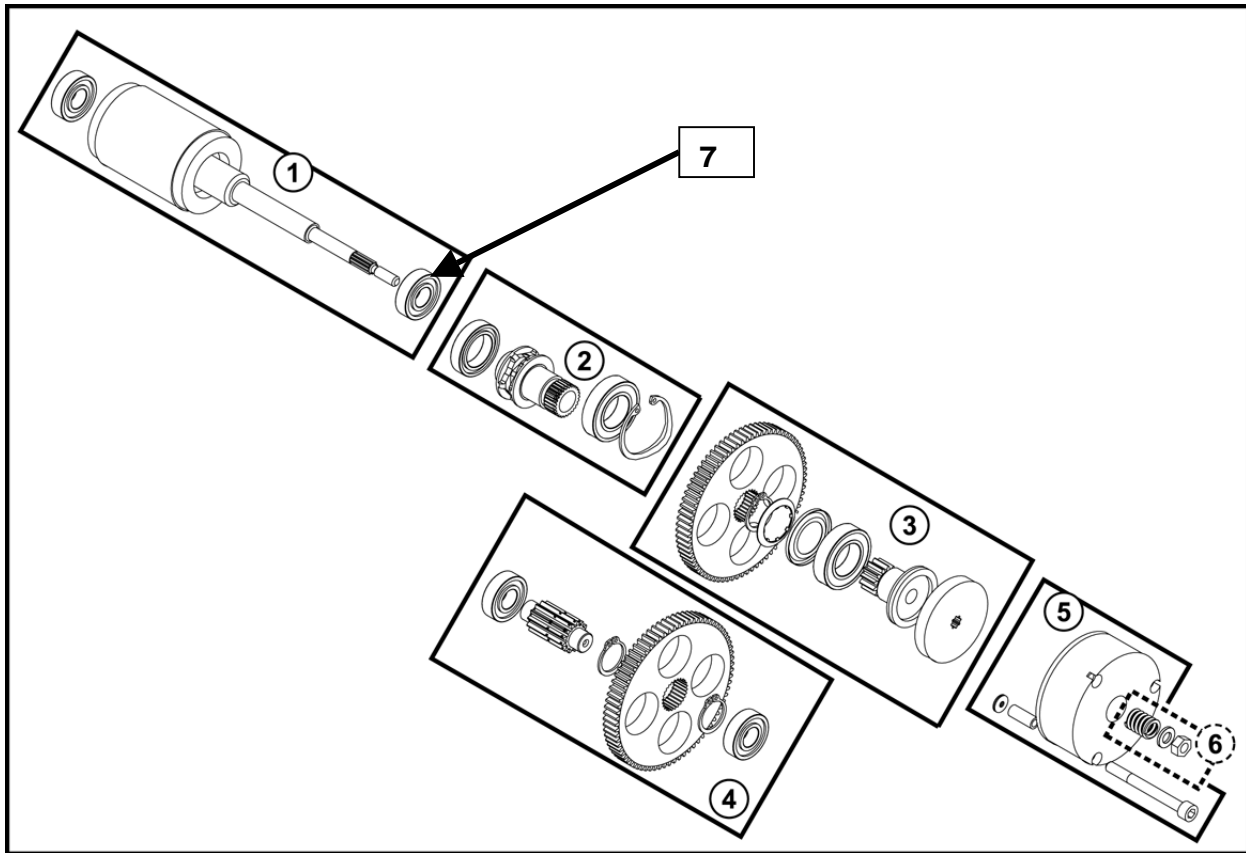

ITEM	PART NUMBER	DESCRIPTION	QTY PER
1a	2218040	ROTOR ASSEMBLY – 3 PHASE POWER SUPPLY	1
1b	52315094	ROTOR ASSEMBLY – 1 PHASE POWER SUPPLY	1
2	2218041	CHAIN SPROCKET ASSEMBLY	1
3	2218042	FRICTION DISC ASSEMBLY FOR SLIP CLUTCH	1
4	2218043	GEAR ASSEMBLY	1
5a	2218030	MOTOR BRAKE ASSY 190 VDC – 460 VAC	1
5b	2218031	MOTOR BRAKE ASSY 100 VDC – 115/208/230 VAC	1
5c	2218032	MOTOR BRAKE ASSY 230 VDC – 575 VAC	1
6	2218044	SLIP CLUTCH SRPING SET	1
7	52309505	BEARING SET (7 TOTAL PER SET)	1



® R&M Materials Handling, Inc  
Springfield, Ohio USA  
☎: 800 955-9967  
[www.rmhoist.com](http://www.rmhoist.com)

LoadMate® Chain Hoist  
LM1 Installation & Maintenance Manual

April 2005

---

LEAVE THIS PAGE BLANK

7.3 Lifting Assembly

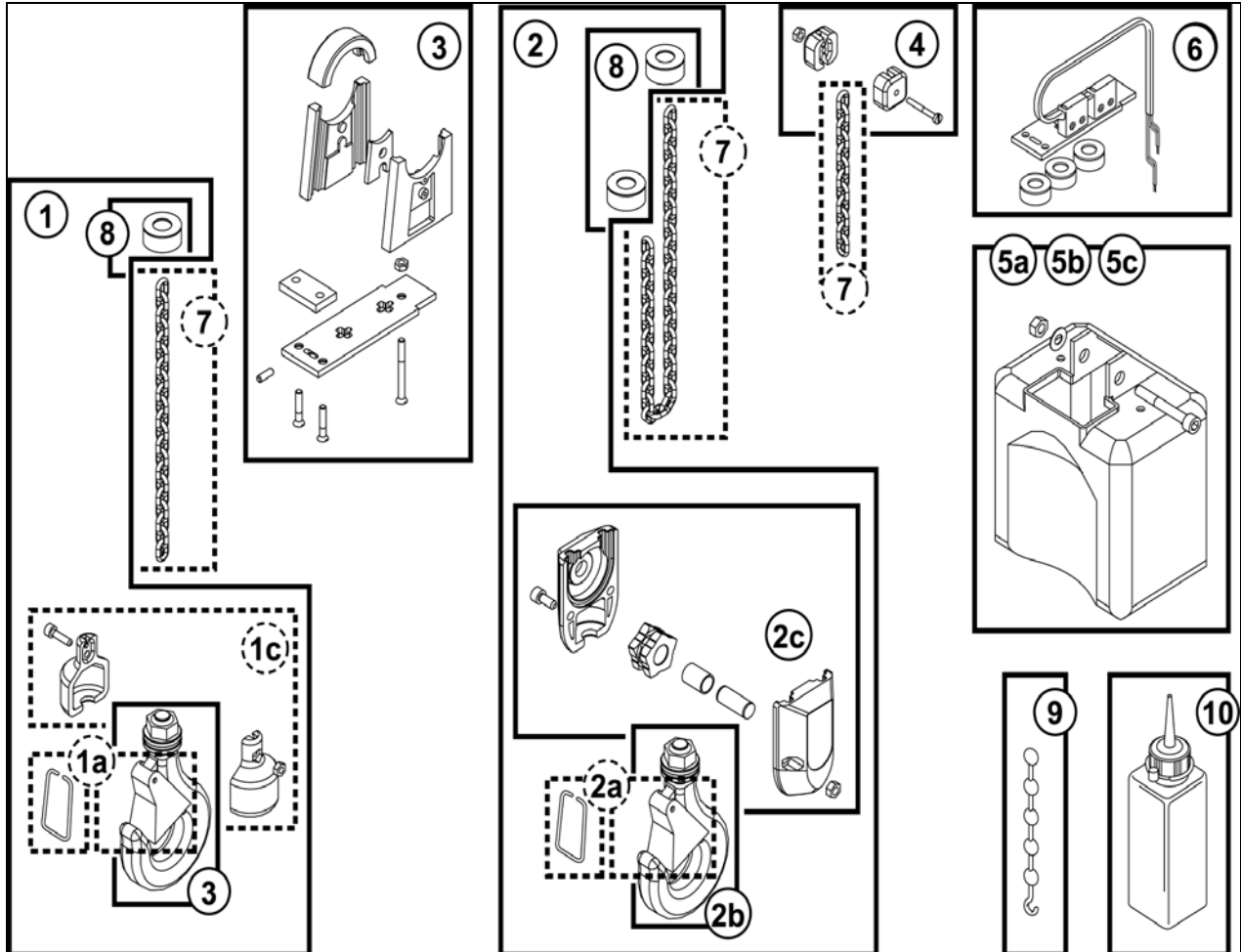



ITEM	PART NUMBER	DESCRIPTION	QTY PER
1	2218045	1-FALL LOAD BLOCK ASSEMBLY	1
1a	001512	1-FALL SAFETY LATCH – WIRE TYPE	1
1a	2212016	1-FALL SAFETY LATCH – STEEL PLATE	1
1b	2218046	1-FALL LOAD HOOK	1
1c	2218047	1-FALL LOAD BLOCK HALVES, PIN AND HARDWARE	-
1d	2213454001	1-FALL LOAD BLOCK CAPACITY STICKER – 1/8 TON	2
1d	2213454002	1-FALL LOAD BLOCK CAPACITY STICKER – 125 kg	2
2	2218048	2-FALL LOAD BLOCK ASSEMBLY	1
2a	001512	2-FALL SAFETY LATCH – WIRE TYPE	1
2a	2212016	2-FALL SAFETY LATCH – STEEL PLATE	1
2b	2218046	2-FALL LOAD HOOK	1
2c	2218085	2-FALL LOAD HOOK HALVES, SPROCKET, AXLE, AND HARDWARE	-
2d	2213308016	2-FALL CAPACITY STICKER – 125 kg	1
2d	2213308007	2-FALL CAPACITY STICKER – 250 kg	1
2d	2213308006	2-FALL CAPACITY STICKER – 1/8 TON	1
2d	2213308001	2-FALL CAPACITY STICKER – 1/4 TON	1
3	2218024	CHAIN GUIDE KIT	1
4	2218025	SLACK FALL STOP ASSEMBLY	1
5a	2218026	CHAIN CONTAINER & HARDWARE – 26FT (8m) MAX	1
5b	2218027	CHAIN CONTAINER & HARDWARE – 52FT (16m) MAX	1
5c	2218028	CHAIN CONTAINER & HARDWARE – 96FT (30m) MAX	1
6	2218029	UPPER / LOWER LIMIT SWITCH ASSEMBLY	1
7a	2218075	LOAD CHAIN – ZINC PLATED	N
7b	52288187	LOAD CHAIN – BLACK	N
7c	52288934	LOAD CHAIN – STAINLESS STEEL (CHECK CAPACITY LIMITS)	N
8a	2218076	RUBBER BUFFER (BUMPER) 1-FALL	2
8b	2218076	RUBBER BUFFER (BUMPER) 2-FALL	3
9	2218077	LOAD CHAIN INSERTION TOOL	1
10	9995008	LOAD CHAIN LUBRICANT	1

#### 7.4 Control Panel Assembly – 3 Phase Power Supply

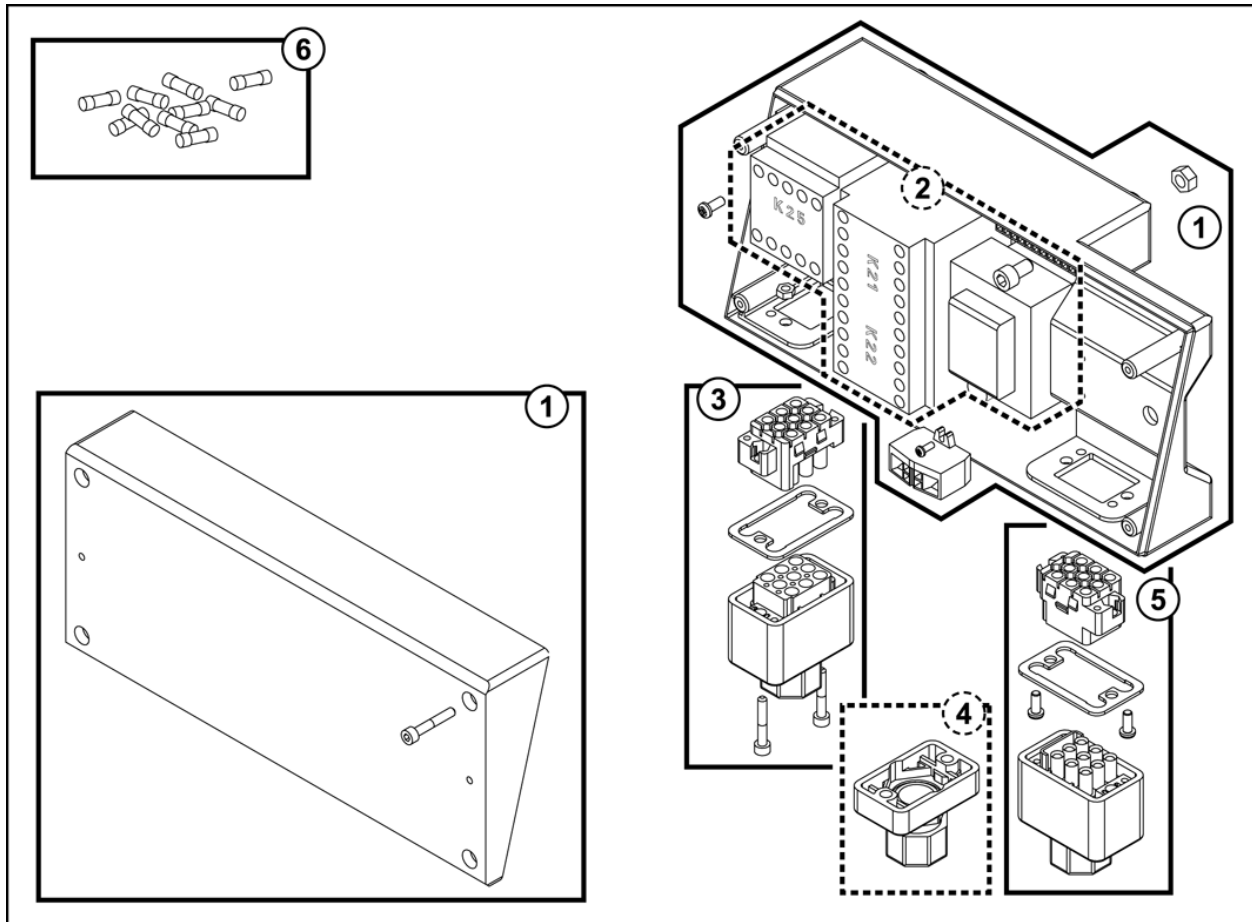

ITEM	PART NUMBER	DESCRIPTION	QTY PER
1	52308791	CONTROL BOX COVER SET	1
2a	2218095	PC BOARD 208/230VAC – TWO SPEED ( 115V CONTROL VOLTAGE )	1
2b	2218094	PC BOARD 460VAC – TWO SPEED ( 115V CONTROL VOLTAGE )	1
2c	2218096	PC BOARD 575VAC – TWO SPEED ( 115V CONTROL VOLTAGE )	1
3	2249982	POWER PLUG SET (OPTIONAL ON C01 HOIST)	1
4	2249947	POWER CABLE GLAND	1
5	2249945	X23 PUSH BUTTON PLUG SET FOR CONTROL BOX	1
6a	52314754	CONTROL CIRCUIT FUSES – 115V CONTROL VOLTAGE – SET OF 10	1
6b	2219988	CONTROL CIRCUIT FUSES – 48V CONTROL VOLTAGE – SET OF 10	1

### 7.5 Control Panel Assembly – 115 Volt 1-Phase Power Supply

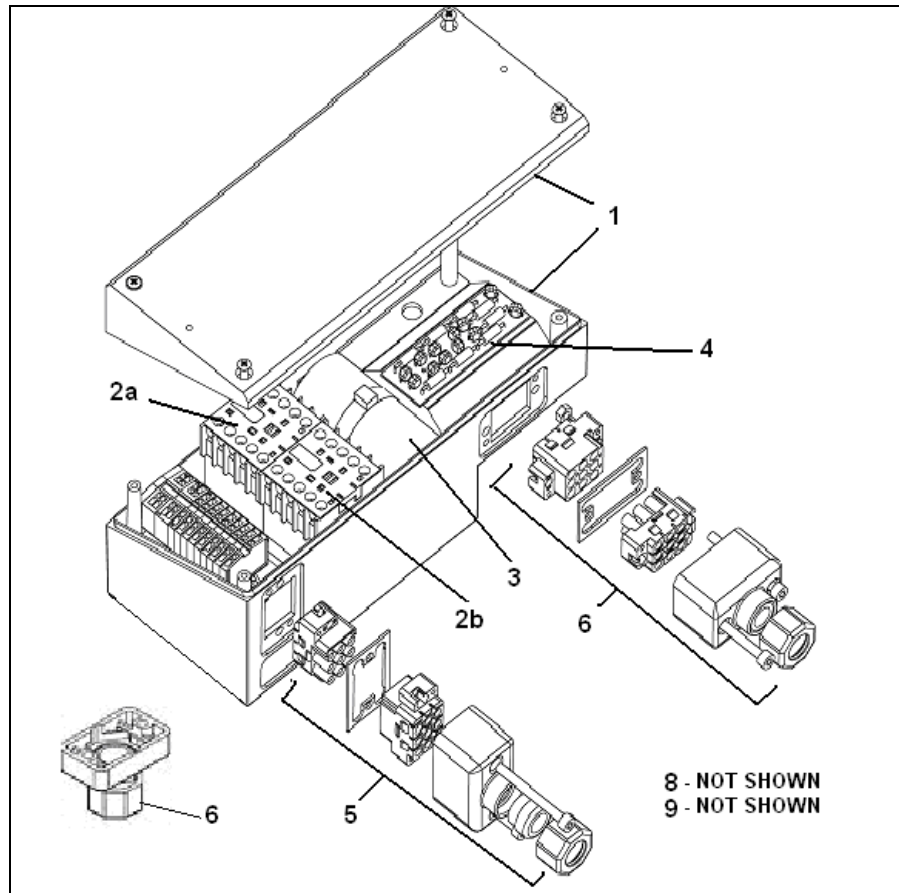

ITEM	PART NUMBER	DESCRIPTION	QTY
1	2218078	ELECTRICAL ENCLOSURE SET – BASE AND COVER	1
A	52314680	CONTROLS & ENCLOSURE ASSEMBLY – 1+2+3+4	1
2	52315603	CONTACTORS K21 or K22 – 115 VAC 1-PHASE	1
3	52315864	MOTOR CAPACITOR 115VAC 60Hz 1-PHASE MOTOR	1
4	52315863	MOTOR BRAKE RECTIFIER ASSY – 115 VAC 1-PHASE	1
5	2249982	POWER SUPPLY PLUG ASSEMBLY – OPTIONAL ON C01	1
6	2249947	POWER SUPPLY CABLE GLAND	1
7	2249945	X23 PUSH BUTTON PLUG ASSEMBLY ON CONTROL BOX	1
8	52315883	CONTROL FUSES – SET OF 10 – 115 VAC 1-PHASE	1
9	52281214	FUSE HOLDER	1

7.6 Push Button Assembly – Vertical Pairs of Buttons

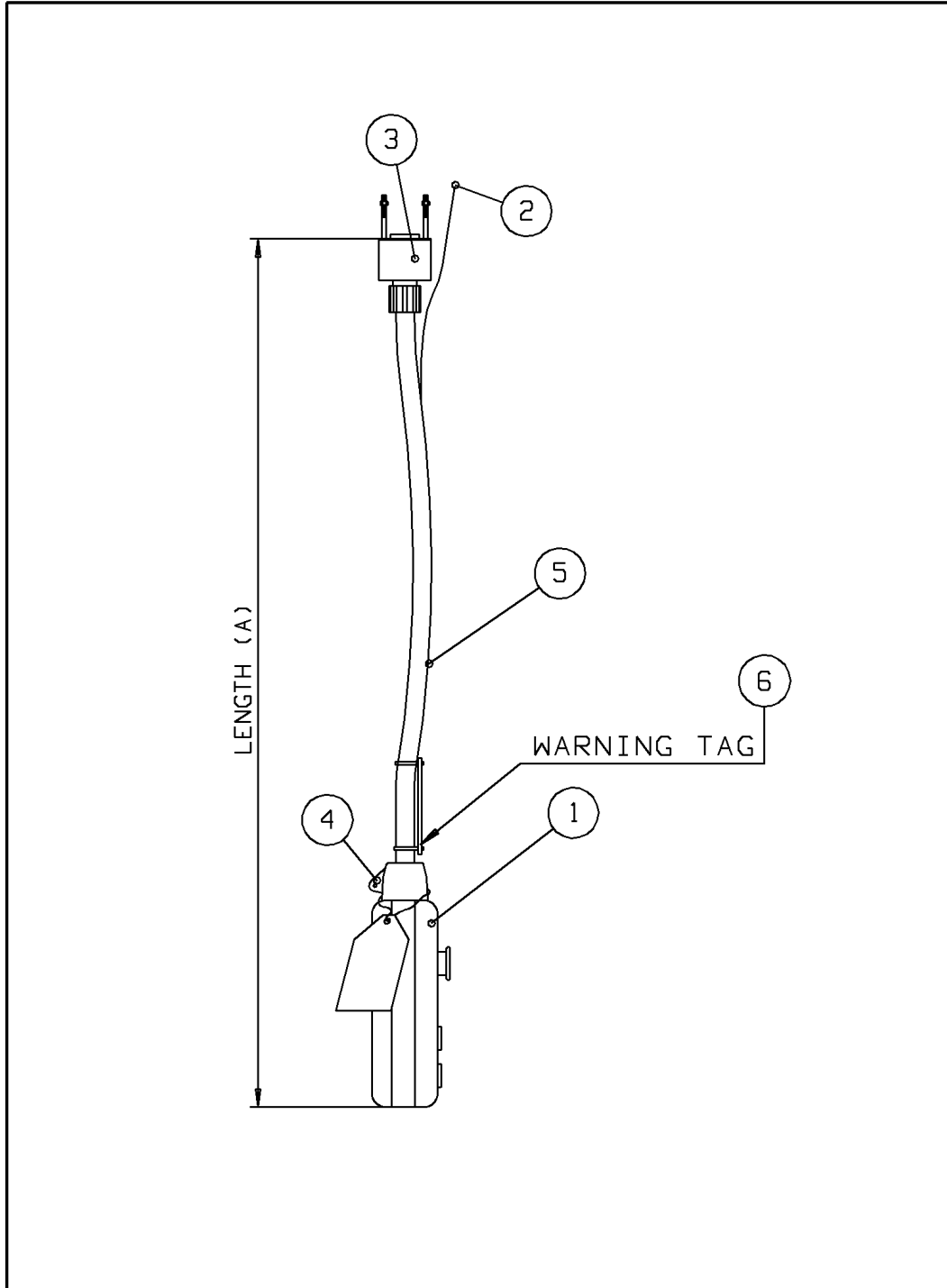



ITEM	PART NUMBER	DESCRIPTION	QTY
-	2309673010	E-STOP, SINGLE SPEED HOIST – 10 FT P/B ASSEMLBY	1
-	2309673015	E-STOP, SINGLE SPEED HOIST – 15 FT P/B ASSEMLBY	1
-	2309673020	E-STOP, SINGLE SPEED HOIST – 20 FT P/B ASSEMLBY	1
-	2309674010	E-STOP, TWO SPEED HOIST – 10 FT P/B ASSEMBLY	1
-	2309674015	E-STOP, TWO SPEED HOIST – 15 FT P/B ASSEMLBY	1
-	2309674020	E-STOP, TWO SPEED HOIST – 20 FT P/B ASSEMLBY	1
1	2212932011	E-STOP, SS HOIST PUSHBUTTON ENCLOSURE ASSEMBLY	1
1	2212932012	E-STOP, TS HOIST PUSHBUTTON ENCLOSURE ASSEMBLY	1
2	2218000	UPPER SUSPENSION KIT	1
3	7285035	PLUG KIT	1
5	52292266	PUSH BUTTON ELECTRICAL CONTROL CABLE	1
6	<a href="#">2309414001</a>	<a href="#">R&amp;M PUSHBUTTON WARNING TAG - ENGLISH</a>	1

7.7 Pushbutton Assembly – Horizontal Pairs of Buttons

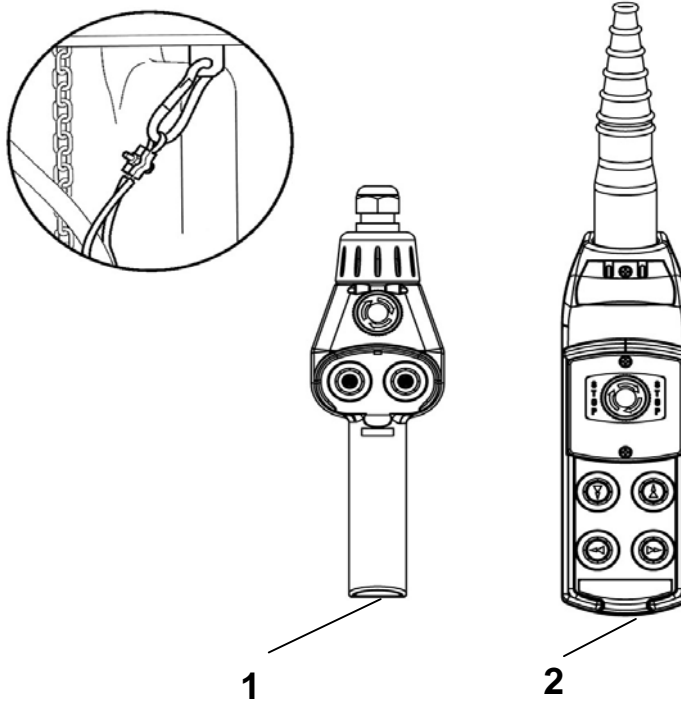

ITEM	PART NUMBER	DESCRIPTION	QTY
1	52301832	PISTOL GRIP P/B CONTROL ASSEMBLY – TWO SPEED	1
1	2309414001	R&M PUSHBUTTON WARNING TAG - ENGLISH	1



**LEAVE THIS PAGE BLANK**

*Authorized Sales & Service*

**J. HERBERT CORPORATION**

**Call 1-800-255-0588**

407-846-0588 Fax: 846-1066

[info@jherbertcorp.com](mailto:info@jherbertcorp.com)

**Visit us online:**

[www.jherbertcorp.com](http://www.jherbertcorp.com)