



Stamped Steel — Ideal For Construction

SHA Hand Chain Hoist

The **SHA** stamped steel, hand chain hoist is an excellent, lower cost option in the Yale line. The compact, lightweight design is ideal for construction and contractor applications where portability and easy rigging are critical.

- **Capacities and Lift** - Rated loads from ½ to 50 tons with standard lifts of 10, 15 & 20 feet. Standard hand chain drop is 2-feet less than lift.
- **Compact and Lightweight** - Designed for portability and easy installation. Compact gear housing provides low headroom.
- **Easy to Operate** - Lubricated bearings and bushings, bearing-mounted options, and heat-treated spur gearing ensure smooth and efficient operation with minimal effort. Designed for easy inspection and maintenance.
- **Safety and Load Control** - Mechanical load brake engages instantly for precise load holding and positioning. 360° swivel hooks with safety latches ensure positive load engagement.
- **Durable** - Through hardened load chain provides added strength and wear resistance for greater chain life. Stamped steel housing withstands rugged conditions.
- **Lifetime Warranty**

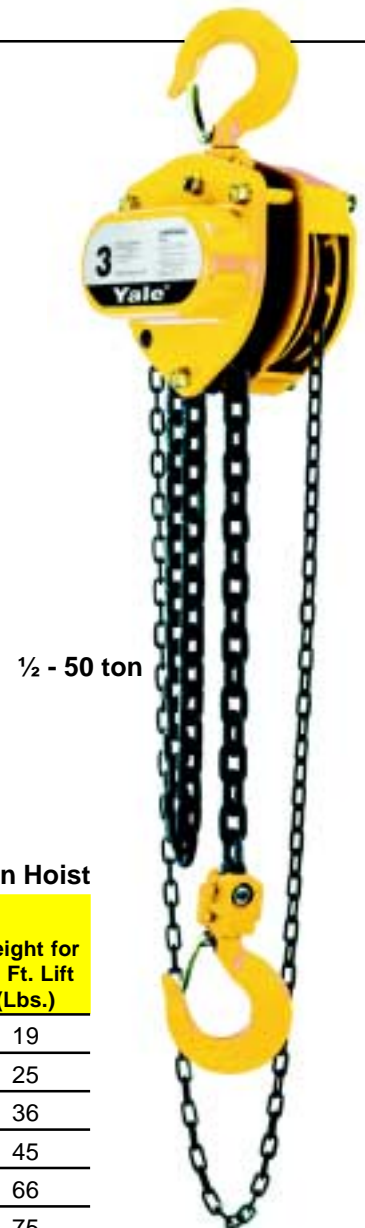

½ - 50 ton

S P E C I F I C A T I O N S

SHA Hand Chain Hoist

Capacity		Model Number	Lifts (Ft.)**	Strands Of Load Chain	Minimum Headroom (In.)	Average Overhaul for 1 Ft. Lift (Ft.)	Net Pull to Lift Rated Load (Lbs.)	Weight for 10 Ft. Lift (Lbs.)
Lbs.	Tons							
1000	½	SHA-½	10/15/20	1	10 ¹ / ₄	32	55	19
2000	1	SHA-1	10/15/20	1	11 ¹³ / ₁₆	56	53	25
3000	1½	SHA-1½	10/15/20	1	13 ⁹ / ₁₆	75	65	36
4000	2	SHA-2	10/15/20	1	15	75	74	45
6000	3	SHA-3	10/15/20	1	17 ¹ / ₈	95	84	66
10000	5	SHA-5	10/15/20	3	22 ⁵ / ₈	203	79	75
16000	8	SHA-8	10/20	3	32 ¹ / ₂	312.5	77	158
20000	10	SHA-10	10/20	3	32 ¹ / ₂	312.5	95	158
24000	12	SHA-12	10/20	5	50 ⁵ / ₈	526	84	328
30000	15	SHA-15	10/20	5	50 ⁵ / ₈	526	103	328
40000	20	SHA-20	10	6	52 ³ / ₈	312.5 x 2 †	99 x 2 †	535
50000	25*	SHA-25	10	8	52 ⁷ / ₈	416.7 x 2 †	97 x 2 †	680
60000	30*	SHA-30	10	10	65	526.3 x 2 †	104 x 2 †	945
80000	40*	SHA-40	10	14	73 ⁵ / ₁₆	714.3 x 2 †	101 x 2 †	1400
100000	50*	SHA-50	10	20	77 ⁵ / ₈	1000 x 2 †	104 x 2 †	1840

* 25, 30, 40 and 50 Ton models available by special order - consult factory.

** standard lifts shown. Other lifts available - consult factory.

† SHA-20 through SHA-50 models have two hand chains.

DIMENSIONS

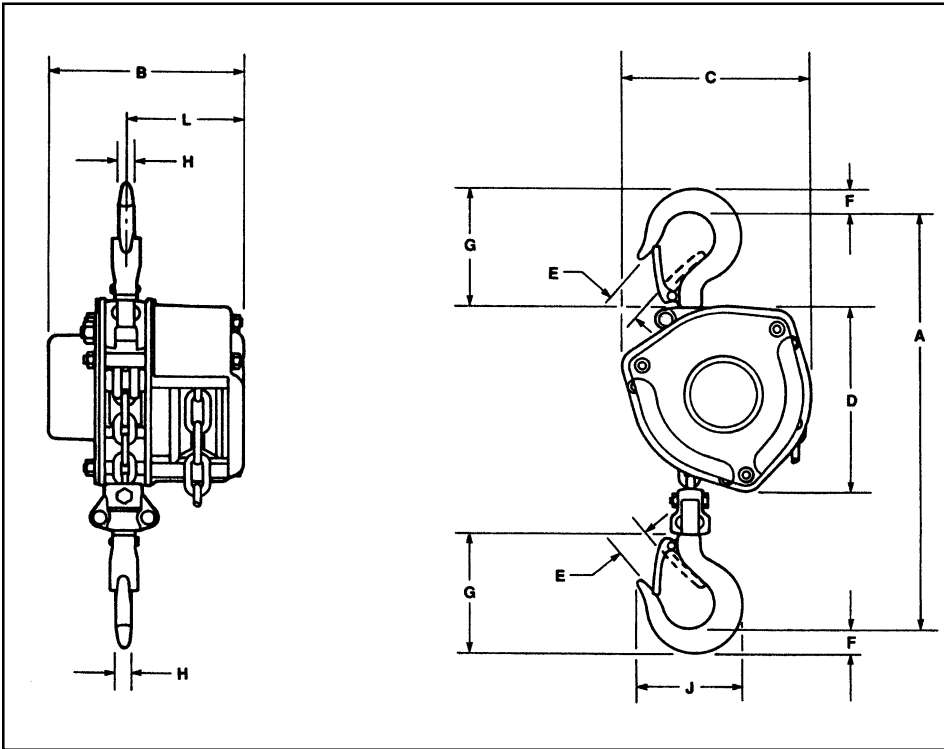

SHA Model

⚠ WARNING

Overloading and improper Use Can Result in injury

To Avoid Injury:

- Do not exceed working load limit, load rating or capacity.
- Do not use to lift people or loads over people.
- Use only alloy chain and attachments for overhead lifting.
- Read and follow all instructions

Model Number	Rated Load (Ton)	A	B	C	D	E	F	G	H	J	K	No. of Load Chains
SHA-1/2	1/2	10 ¹ / ₄	5 ⁷ / ₁₆	5 ⁷ / ₁₆	5 ¹ / ₄	1 ⁵ / ₁₆	5/8	3 ³ / ₈	7/16	2 ¹⁵ / ₁₆	3 ¹ / ₄	1
SHA-1	1	11 ³ / ₁₆	5 ¹⁵ / ₁₆	6 ¹ / ₄	6	1 ¹ / ₈	5/16	4 ¹ / ₁₆	5/8	3 ¹⁹ / ₃₂	3 ⁷ / ₁₆	1
SHA-1 1/2	1 1/2	13 ⁹ / ₁₆	6 ¹ / ₂	7 ¹ / ₄	6 ¹ / ₈	1 ⁵ / ₁₆	1 ¹ / ₈	3 ⁹ / ₁₆	1 ³ / ₁₆	4	3 ⁵ / ₈	1
SHA-2	2	15	7 ¹ / ₄	8 ⁷ / ₁₆	8 ¹ / ₂	1 ³ / ₈	1 ¹ / ₄	4 ¹⁵ / ₁₆	7/8	4 ⁹ / ₁₆	3 ⁷ / ₈	1
SHA-3	3	17 ¹ / ₈	7 ¹³ / ₁₆	10	10	1 ⁹ / ₁₆	1 ¹ / ₂	5 ³ / ₄	1 ¹ / ₈	5 ⁷ / ₁₆	4 ³ / ₈	1
SHA-5	5	22 ⁵ / ₈	6 ¹ / ₂	11 ¹ / ₈	7 ⁵ / ₁₆	1 ⁷ / ₈	1 ¹³ / ₁₆	6 ¹³ / ₁₆	1 ³ / ₈	6 ¹ / ₂	3 ⁵ / ₈	3
SHA-8	8	32 ¹ / ₂	7 ¹³ / ₁₆	15 ¹ / ₁₆	—	2 ³ / ₄	2 ¹ / ₂	9 ¹⁷ / ₃₂	1 ¹³ / ₁₆	8 ³ / ₄	4 ³ / ₁₆	3
SHA-10	10	32 ¹ / ₂	7 ¹³ / ₁₆	15 ¹ / ₁₆	—	2 ³ / ₄	2 ¹ / ₂	9 ¹⁷ / ₃₂	1 ¹³ / ₁₆	8 ³ / ₄	4 ³ / ₁₆	3
SHA-12	12	50 ⁵ / ₈	7 ¹³ / ₁₆	20 ⁵ / ₁₆	—	2 ¹⁵ / ₁₆	2 ²⁷ / ₃₂	11 ¹³ / ₁₆	2 ⁷ / ₁₆	10 ¹¹ / ₁₆	4 ³ / ₁₆	5
SHA-15	15	50 ⁵ / ₈	7 ¹³ / ₁₆	20 ⁵ / ₁₆	—	2 ¹⁵ / ₁₆	2 ²⁷ / ₃₂	11 ¹³ / ₁₆	2 ⁷ / ₁₆	10 ¹¹ / ₁₆	4 ³ / ₁₆	5
SHA-20	20	52 ³ / ₈	12 ¹ / ₈	28 ⁷ / ₈	—	3 ¹ / ₈	3 ⁹ / ₁₆	12 ⁹ / ₁₆	3 ⁹ / ₁₆	12 ¹ / ₂	6 ¹ / ₁₆	6
SHA-25	25	52 ⁷ / ₈	14 ¹ / ₂	28 ⁷ / ₈	—	3 ¹ / ₈	3 ¹ / ₂	12 ⁹ / ₁₆	3 ⁹ / ₁₆	12 ¹ / ₂	7 ¹ / ₄	8
SHA-30	30	65	16 ⁷ / ₈	29 ⁵ / ₈	—	4 ³ / ₁₆	4 ³¹ / ₃₂	18 ³ / ₁₆	4 ⁷ / ₁₆	15 ³ / ₁₆	8 ⁷ / ₁₆	10
SHA-40	40	73 ⁵ / ₁₆	20 ¹ / ₈	29 ⁵ / ₈	—	4 ¹ / ₁₆	6 ³ / ₁₆	22 ¹ / ₄	5 ¹ / ₄	17 ⁵ / ₈	10 ¹ / ₁₆	14
SHA-50	50	77 ⁵ / ₈	25 ⁷ / ₈	29 ⁵ / ₈	—	4 ³ / ₄	6 ³ / ₄	23 ³ / ₄	6 ⁷ / ₈	20 ¹ / ₄	12 ¹⁵ / ₁₆	20

Dimensions in Inches unless otherwise indicated

Authorized Sales & Service
J. HERBERT CORPORATION
 Call 1-800-255-0588
 407-846-0588 Fax: 846-1066
 info@jherbertcorp.com

Visit us online:
 www.jherbertcorp.com

**Yale Lift-Tech, division of
 Columbus McKinnon Corporation**
 414 West Broadway Avenue
 P.O. Box 769
 Muskegon, Michigan 49443-0769
 (800) 742-9269 Phone
 (800) 742-9270 Fax



YPB-6
 June 2006
 Printed in USA