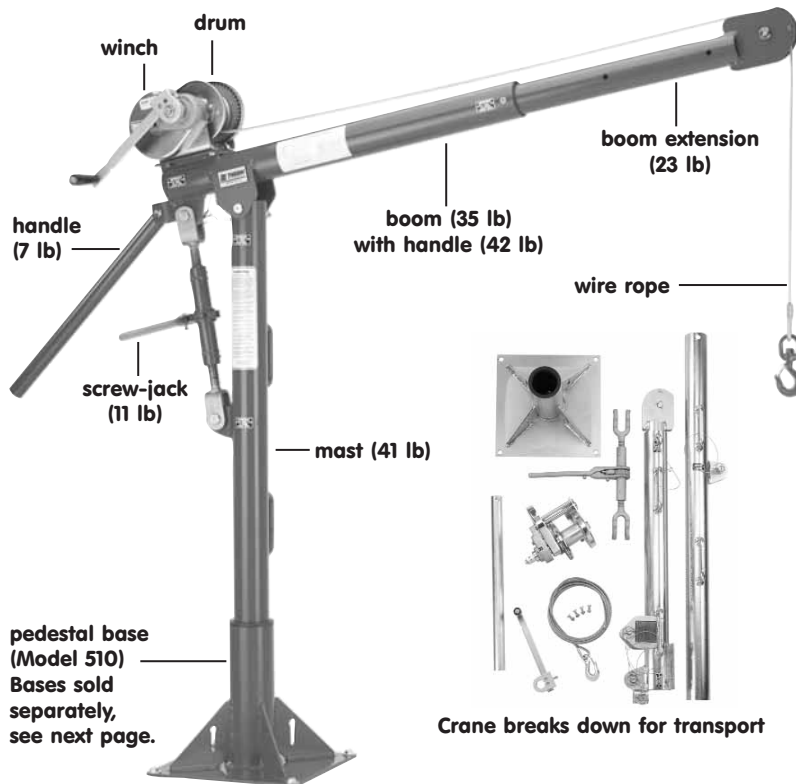

**Model 5110M1 with pedestal base**

**Series 5110  
Portable Davit  
Cranes**
**Hand or Power Winch Operation  
Up to 1000 lb capacity**
*Ordering your crane is as easy as 1...2...3... Select the option that best suits your needs for each item. Fill in the boxes below to create your crane part number.*

<b>1 Crane</b>	<b>2 Optional Winch</b>	<b>3 Finish*</b>
5110		

i.e. 5110M2GAL

\*Leave blank for standard powder coat finish

**4 Order your Base, Wire Rope Assembly and Optional Accessories separately. See next page.**
**■ Two-year Limited Warranty**
**Crane Model**

- **Crane Rotates 360°** on a pin and sleeve bearing in the base. Handle on the boom makes rotation easy.
- **Adjustable Boom** telescopes to 4 different lengths, and adjusts in height while under load with ratchet style screw-jack.
- **Crane Breaks Down** for storage or transport.

**1 Crane Model 5110 – Section 4**

base model	description	approx. ship wt.
5110 <sup>1</sup>	up to 1000 lb – portable davit	160 lb

Please contact factory or nearest Thern Distributor for firm fixed price and delivery.

<sup>1</sup> Base Model includes corrosion resistant electrostatic powder coated finish. Other finishes available see Option 3.

**Winch Models**

- **Hand Winch Operated Models** include spur gear or worm gear hand winch with brake for load control. Model M2 winch can be drill driven, 400 rpm max.
- **Power Winch Operated Models** include electric winch with pendant control and brake. Other power options available, please contact factory.
- **Quick Disconnect Anchor** for quickly attaching or removing wire rope equipped with a swaged ball fitting.

**2 Winch Options – Section 4**

winch	description	approx. ship wt.
M1	M4312PB-K – zinc plated spur gear hand winch	28 lb
M2 <sup>2</sup>	4WM2-K – worm gear hand winch	42 lb
M3	M4312PBSS-K – stainless steel spur gear hand winch	28 lb
E2 <sup>3</sup>	4WP2-K electric winch – 115/1/60 VAC with 6 ft pendant control, see pg. 10, model 4WP2 for details	85 lb
E4 <sup>3</sup>	4777-K electric winch – 115/1/60 VAC with 6 ft pendant control, see pg. 14, model 4777 for details	110 lb
E4DC <sup>3</sup>	4777DC-K electric winch – 12 volt DC with 10 ft pendant control, see pg 14, model 4777DC for details	105 lb

<sup>2</sup> Winch finish is powder coated, for epoxy finish contact factory.

<sup>3</sup> Winch finish is enamel, for epoxy finish contact factory.

**Optional Finishes**

- **Galvanized Finish** provides extra protection against corrosion.
- **Stainless Steel Models** are constructed from all stainless steel with an electro-polished finish for superior corrosion resistance.

**3 Optional Finish (crane only) – Section 4**

finish	description
GAL	galvanized finish – crane only
SS	stainless steel construction – crane only

**4 Series 5110 Bases, Wire Rope Assemblies and Accessories**
**INDEPENDENT BASES – sold separately**

- **Pedestal, Socket, or Wall** mount style.
- **Wheel Base** for floor crane operation. Base legs adjust in length and width. See Model 510R.
- **Important:** Base installation is purchaser's responsibility. Thern recommends consulting a civil engineer or other qualified professional. Contact factory for installation guidelines.

**Independent Bases – Section 4**

base	description	approx. ship wt.
510	pedestal base – powder coat finish (upright mount)	52 lb
510GAL	pedestal base – galvanized finish (upright mount)	52 lb
510SS	pedestal base – stainless steel (upright mount)	52 lb
510F	socket base – powder coat finish (flush mount)	45 lb
510FGAL	socket base – galvanized finish (flush mount)	45 lb
510SSF	socket base – stainless steel (flush mount)	45 lb
510W	wall mount base – powder coat finish	52 lb
510WGAL	wall mount base – galvanized finish	52 lb
510SSW	wall mount base – stainless steel	52 lb
510R	wheel base – enamel finish	313 lb

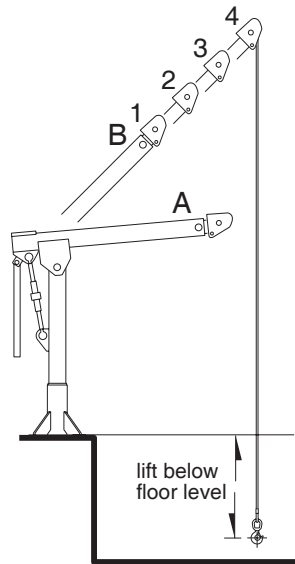
**Important:**

It is the owner's or operator's responsibility to determine the suitability of the equipment to its intended use. Study all applicable codes, manuals, and regulations. Be sure to read the Owner's Manual supplied with the equipment before operating it.

**WIRE ROPE ASSEMBLIES – sold separately**

- **Galvanized or Stainless Steel** wire rope assemblies with swaged ball fitting to work with the quick disconnect anchor on the winch.

**Wire Rope Assemblies – Section 9**

model number	wire rope diameter x length	approx. ship weight
galvanized aircraft cable with swivel hook and swaged ball fitting		
WA25-20NS	1/4 in x 20 ft	4 lb
WA25-28NS	1/4 in x 28 ft	5 lb
WA25-36NS	1/4 in x 36 ft	6 lb
WA25-45NS	1/4 in x 45 ft	7 lb
WA25-60NS	1/4 in x 60 ft	9 lb
WA25-75NS	1/4 in x 75 ft	10 lb
304 stainless steel wire rope with SS eye hook and swaged ball fitting - swivel hook also available please contact factory		
WS25-20NE	1/4 in x 20 ft	5 lb
WS25-28NE	1/4 in x 28 ft	5 lb
WS25-36NE	1/4 in x 36 ft	6 lb
WS25-45NE	1/4 in x 45 ft	7 lb
WS25-60NE	1/4 in x 60 ft	8 lb
WS25-75NE	1/4 in x 75 ft	10 lb

**ACCESSORIES – Section 4**

**Base Cover** – plastic cover fits in the mast hole in the base to help keep water from collecting inside the base when the crane is removed.



**Model No. TK3P**

**Cable Spool** – 316 stainless steel reel winds up wire rope when detached from crane.



**Model No. RW50 12 lb**

**Wire Rope Keeper** – metal bracket attaches to base or other structure to hold free end of the wire rope when detached from crane.



**Model No. B1766**

**Drill-Motor Drive** – 7 amp, 400 rpm drill-motor to power drive the hand winch. Only available for cranes configured with the M2 winch option. 120 VAC drill-motor includes 1-1/8" hex socket drive.



**Model No. ED120BD 12 lb**

**Series 5110 Performance Characteristics**

wire rope dia.	wire rope length	load rating for 5110M1 and M3				load rating for 5110M2, E2, E4, and E4DC				lift below floor level (min – max) <sup>1</sup>
		position 1	position 2	position 3	position 4	position 1	position 2	position 3	position 4	
1/4 in	20 ft	1000 lb	700 lb	600 lb	500 lb	1000 lb	700 lb	600 lb	500 lb	1 – 5 ft
1/4 in	28 ft	1000 lb	700 lb	600 lb	500 lb	1000 lb	700 lb	600 lb	500 lb	9 – 13 ft
1/4 in	36 ft	1000 lb	700 lb	600 lb	500 lb	1000 lb	700 lb	600 lb	500 lb	17 – 21 ft
1/4 in	45 ft	1000 lb	700 lb	600 lb	500 lb	1000 lb	700 lb	600 lb	500 lb	26 – 30 ft
1/4 in	60 ft	1000 lb	700 lb	600 lb	500 lb	1000 lb	700 lb	600 lb	500 lb	41 – 45 ft
1/4 in	75 ft	–	–	–	–	1000 lb	700 lb	600 lb	500 lb	56 – 60 ft

<sup>1</sup> Lift below floor level varies depending on boom position and base configuration. For longer lifts, please contact factory.

See Dimensions on Next Page

**5110 with pedestal base mounted upright**

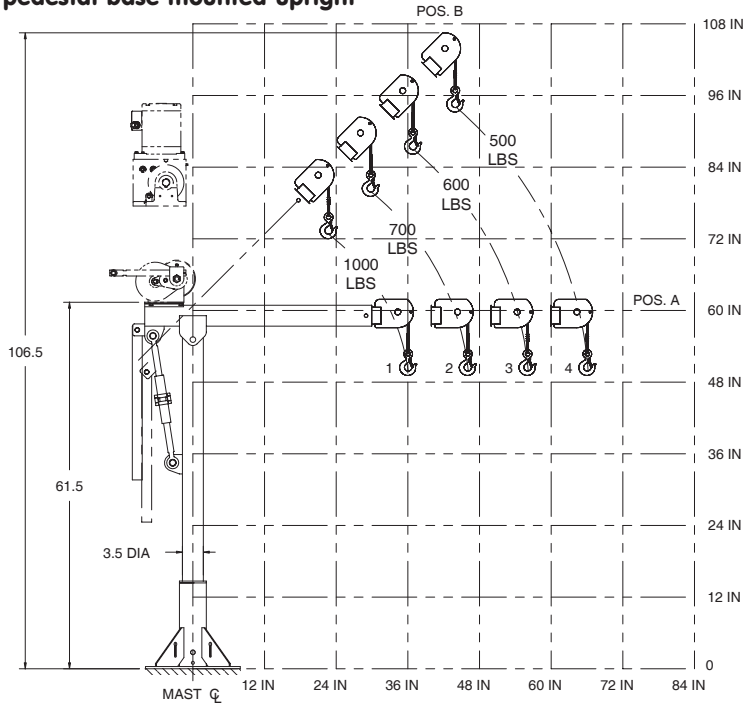

**5110 Upright – Height and Reach**

boom position	hook reach	hook height
A-1	36 in	50 in
A-2	46 in	50 in
A-3	56 in	50 in
A-4	66 in	50 in
B-1	23 in	73 in
B-2	30 in	80 in
B-3	37 in	87 in
B-4	44 in	94 in

Dimensions are for reference only and subject to change without notice.

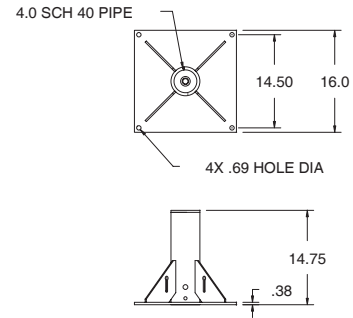

**5110 with wall mount base or socket base mounted flush**

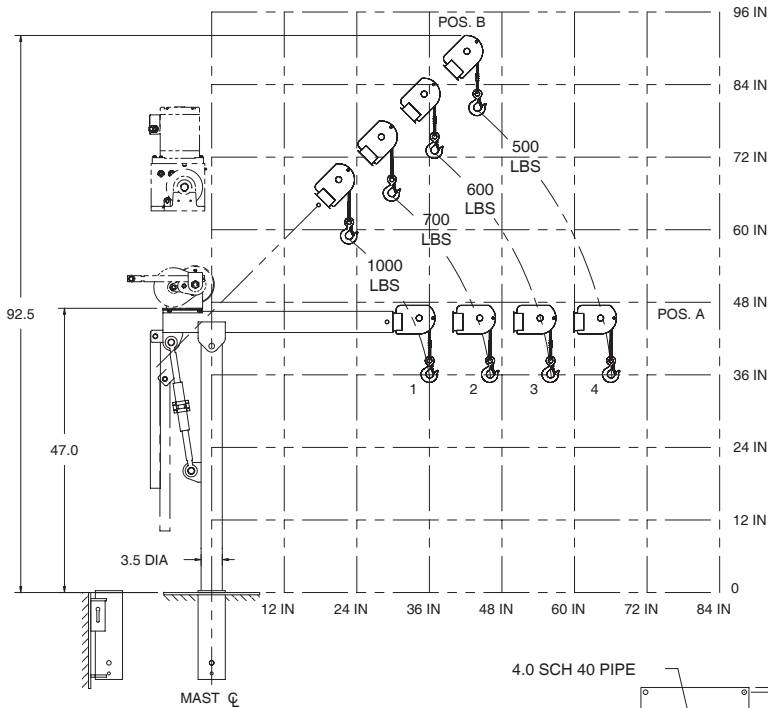

**5110 Flush – Height and Reach**

boom position	hook reach	hook height
A-1	36 in	36 in
A-2	46 in	36 in
A-3	56 in	36 in
A-4	66 in	36 in
B-1	23 in	59 in
B-2	30 in	66 in
B-3	37 in	73 in
B-4	44 in	80 in

Dimensions are for reference only and subject to change without notice.

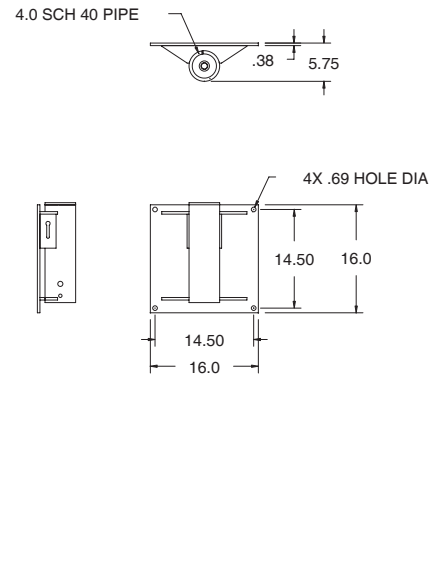

Cranes  
Section 4

See Additional Dimensions on Next Page

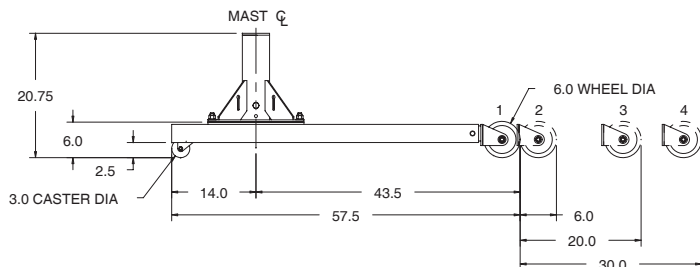
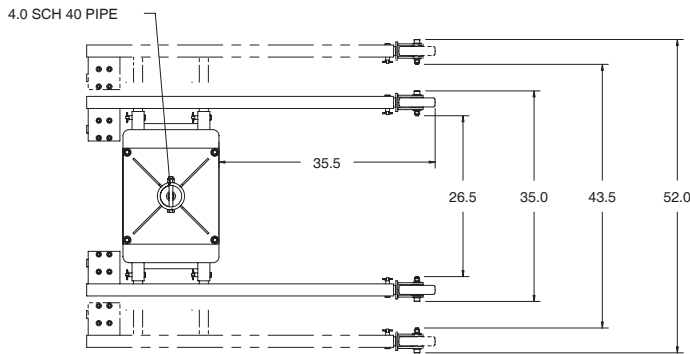
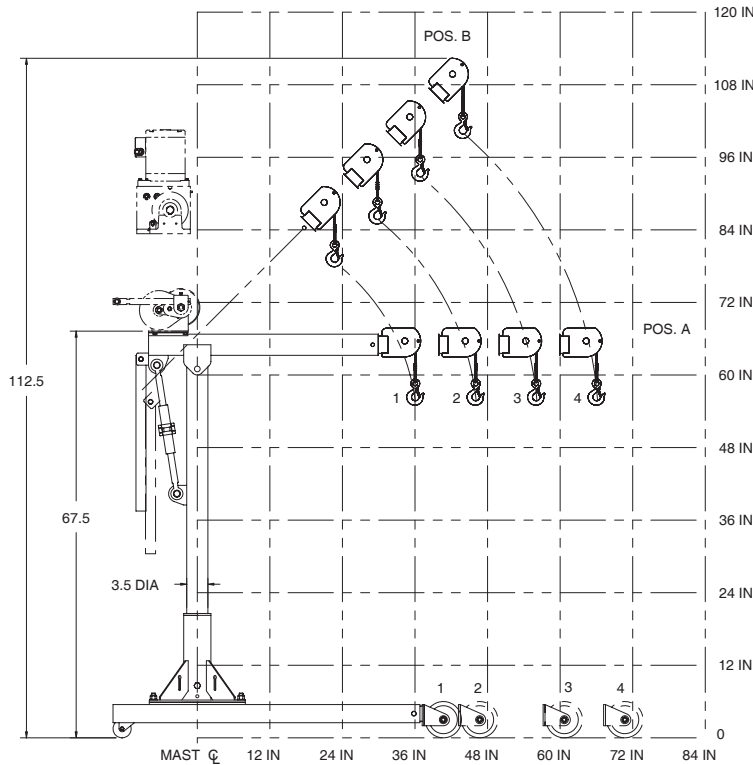
**5110 with Model 510R wheel base**

**5110 with 510R Wheel Base – Height and Reach**

boom position	hook reach	hook height
A-1	36 in	56 in
A-2	46 in	56 in
A-3	56 in	56 in
A-4	66 in	56 in
B-1	23 in	79 in
B-2	30 in	86 in
B-3	37 in	93 in
B-4	44 in	100 in

Dimensions are for reference only and subject to change without notice.

**Important:**

Crane DOES NOT rotate in base when assembled in 510R wheel base.

 Cranes  
 Section 4

Wheel Base sold separately for floor crane operation. See Wheel Base Model 510R on page 35.

*Authorized Sales & Service*  
**J. HERBERT CORPORATION**  
 Call 1-800-255-0588  
 407-846-0588 Fax: 846-1066  
 info@jherbertcorp.com

**Visit us online:**  
[www.jherbertcorp.com](http://www.jherbertcorp.com)

**Load Ratings for 5110 with 510R Wheel Base**

Crane Load Ratings	Leg Position 1	Leg Position 2	Leg Position 3	Leg Position 4
Boom Position 1	1000 lb	1000 lb	1000 lb	1000 lb
Boom Position 2	700 lb	700 lb	700 lb	700 lb
Boom Position 3	do not use	600 lb	600 lb	600 lb
Boom Position 4	do not use	500 lb	500 lb	500 lb

**Important:**

It is the owner's or operator's responsibility to determine the suitability of the equipment to its intended use. Study all applicable codes, manuals, and regulations. Be sure to read the Owner's Manual supplied with the equipment before operating it.