

PARTS, OPERATION AND MAINTENANCE MANUAL

for

MANUAL CHAIN HOIST MODELS

VL2-005
1/2 ton

VL2-010
1 ton

VL2-015
1-1/2 ton

VL2-020
2 ton

VL2-030
3 ton

VL2-050
5 ton

VL2-080
8 ton

VL2-100
10 ton

VL2-150
15 ton

VL2-200
20 ton

Including **S•COR•E** (Spark and Corrosion Resistant) Features
Unless otherwise noted, tons in this manual are metric tons (2,200 lbs.)

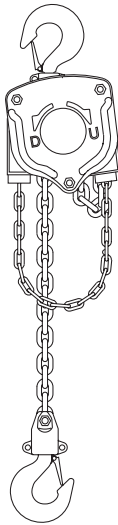

(Dwg. MHP0037)

1/2, 1, 1-1/2 and 2 ton



(Dwg. MHP0038)

3 and 5 ton

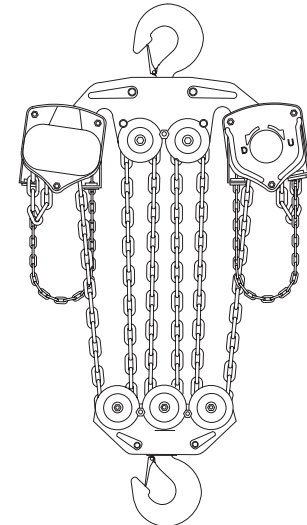

(Dwg. MHP0039)

15 ton

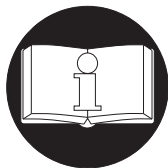

READ THIS MANUAL BEFORE USING THESE PRODUCTS. This manual contains important safety, installation, operation and maintenance information. Make this manual available to all persons responsible for the installation, operation and maintenance of these products.

WARNING

Do not use this hoist for lifting, supporting, or transporting people or lifting or supporting loads over people.

Always operate, inspect and maintain this hoist in accordance with American National Standards Institute Safety Code (ASME B30.16) and any other applicable safety codes and regulations.

Form MHD56012
Edition 8
July 2004
71116107
© 2004 Ingersoll-Rand Company

Authorized Sales & Service
J. HERBERT CORPORATION
Call 1-800-255-0588
407-846-0588 Fax: 846-1066
info@jherbertcorp.com
Visit us online:
www.jherbertcorp.com

 **Ingersoll-Rand®**

SAFETY INFORMATION

This manual provides important information for all personnel involved with the safe installation, operation and proper maintenance of this product. Even if you feel you are familiar with this or similar equipment, you should read this manual before operating the product.

Danger, Warning, Caution and Notice

Throughout this manual there are steps and procedures which, if not followed, may result in a hazard. The following signal words are used to identify the level of potential hazard.



DANGER

Indicates an imminently hazardous situation which, if not avoided, will result in death or serious injury.



WARNING

Indicates a potentially hazardous situation which, if not avoided, could result in death or serious injury.



CAUTION

Indicates a potentially hazardous situation which, if not avoided, may result in minor or moderate injury or property damage.

NOTICE

Indicates information or a company policy that relates directly or indirectly to the safety of personnel or protection of property.

Safety Summary



WARNING

- Do not use this hoist for lifting, supporting, or transporting people or lifting or supporting loads over people.
- Hoists are designed to provide a 4 to 1 safety factor.

Supporting structures and load-attaching devices used in conjunction with this hoist must provide an adequate safety factor to handle the rated load, plus the weight of the hoist and attached equipment. This is the customer's responsibility. If in doubt, consult a registered structural engineer.

Ingersoll-Rand hoists are manufactured in accordance with the latest ASME B30.16 standards.

The National Safety Council, Accident Prevention Manual for Industrial Operations, Eighth Edition and other recognized safety sources make a common point: Employees who work near cranes or assist in hooking on or arranging a load should be instructed to keep out from under the load. From a safety standpoint, one factor is paramount: conduct all lifting operations in such a manner that if there were an equipment failure, no personnel would be injured. This means keep out from under a raised load and keep out of the line of force of any load.

The Occupational Safety and Health Act of 1970 generally places the burden of compliance with the user, not the manufacturer. Many OSHA requirements are not concerned or connected with the manufactured product but are, rather, connected with the final installation. It is the owner's and user's responsibility to determine the suitability of a product for any particular use. It is recommended that all applicable industry, trade association, federal, state and local regulations be checked. Read all operating instructions and warnings before operation.

Rigging: It is the responsibility of the operator to exercise caution, use common sense and be familiar with proper rigging techniques. Refer to ASME B30.9 for rigging information, American Society of Mechanical Engineers, Three Park Avenue, New York, NY 10016.

WARNING TAG

Each hoist is supplied from the factory with the warning tag shown. If tag is not attached to your unit, order a new tag and install it. Refer to the parts list for the part number. Read and obey all warnings and other safety information attached to this hoist. Tag may be shown smaller than actual size.

⚠ WARNING

Failure to follow these warnings may result in death, severe injury or property damage:

- Read manual before using this product.
- Do not lift, lower or pull more than rated load.
- Do not lift people or loads over people.
- Do not operate with twisted or damaged chain or kinked, frayed or cut rope or strap.
- Do not operate lever hoist or puller with handle extension (cheaters).
- Do not operate if damaged or malfunctioning.
- Do not operate when chain, rope or strap cannot form straight line with load.
- Do not operate with other than manual power.
- Do not operate with open latch, twisted hook or without a latch.
- Always keep minimum of 3 wraps of wire rope or 2 wraps of strap on drum.
- Do not remove or obscure warning labels.



SAFE OPERATING INSTRUCTIONS

The following warnings and operating instructions have been adapted in part from American National Standard ASME B30.16 and are intended to avoid unsafe operating practices which might lead to injury or property damage.

Ingersoll-Rand recognizes that most companies who use hoists have a safety program in force in their plants. In the event that some conflict exists between a rule set forth in this publication and a similar rule already set by an individual company, the more stringent of the two should take precedence.

Safe Operating Instructions are provided to make an operator aware of dangerous practices to avoid and are not necessarily limited to the following list. Refer to specific sections in the manual for additional safety information.

1. Only allow personnel trained in safety and operation to operate hoist.
2. Only operate a hoist if you are physically fit to do so.
3. When a **“DO NOT OPERATE”** sign is placed on hoist, do not operate hoist until sign has been removed by designated personnel.
4. Before each shift, the operator should inspect hoist for wear or damage.
5. Never use a hoist which inspection indicates is worn or damaged.
6. Periodically, inspect hoist thoroughly and replace worn or damaged parts. Refer to **“INSPECTION”** section.
7. Lubricate hoist regularly. Refer to **“LUBRICATION”** section.
8. Do not use hoist if hook latch has been sprung or broken.
9. Check that hook latches are engaged before using.
10. Never splice a hoist chain by inserting a bolt between links.
11. Only lift loads less than or equal to rated capacity of hoist. Refer to **“SPECIFICATIONS”** section.
12. Never use the hoist chain as a sling.
13. Never operate a hoist when load is not centered under top hook. Do not **“side pull”** or **“yard.”**
14. Never operate a hoist with twisted, kinked, **“capsized”** or damaged load chain.
15. Do not force a chain or hook into place by hammering.
16. Never insert point of hook into a chain link.
17. Be certain load is properly seated in saddle of hook, and hook latch is engaged.
18. Do not support load on tip of hook.
19. Never run load chain over a sharp edge. Use a sheave.
20. When using two hoists to suspend one load, select two hoists each having a rated capacity equal to or more than the load. This provides adequate safety in the event of a sudden load shift.
21. Pay attention to the load at all times when operating hoist.
22. Always ensure that you, and all other people, are clear of load path. Do not lift a load over people.
23. Never use hoist for lifting or lowering people, and never allow anyone to stand on a suspended load.
24. Ease slack out of chain and sling when starting a lift. Do not jerk load.
25. Do not swing a suspended load.
26. Do not leave a load suspended when hoist is unattended or not in use.
27. Never weld or cut a load suspended by the hoist.
28. Never use hoist chain as a welding electrode.
29. Do not operate hoist if chain jumping, excessive noise, jamming, overloading or binding occurs.
30. Keep load from hitting load chain.
31. Only operate the hoist with manual power.
32. After use, or when in a non-operational mode, hoist should be secured against unauthorized and unwarranted use.

SPECIFICATIONS

General

The VL2 Manual Chain Hoist can be mounted to the suspension shaft of a trolley or a permanent mounting structure. The hoist is designed to lift and lower loads up to rated capacity with minimal effort.

To determine your hoist configuration refer to the capacity and serial number nameplate for serial and model number information.

Model Code Explanation

Model Code Example:	VL2-050-10-8V	VL2	-	050	-	10	-	8	V
Series									
Hoist Capacity									
S•COR•E									
Lift									
Hand Chain Drop									
Options									

Series	Hoist Capacity	S•COR•E	Lift: (Hoist load chain/hook travel)	Hand Chain Drop: (Hand chain is 2 ft. (0.6 m) less than lift)	Options
VL2	= 005, 010, 015, 020, 030, 050 , 080, 100, 150 and 200	- = Standard CP = Copper Plated SB = Solid Bronze	10 = Hook travel, 10 std , 15 and 20 ft. XX = Specify length	8 = Lift 10 ft. chain drop 8 ft. (standard) 13 = Lift 15 ft. chain drop 13 ft. 18 = Lift 20 ft. chain drop 18 ft. XX = Specify drop	V = Overload Clutch (standard) H = Zinc Plated hand chain S•COR•E N = Nickel plated load chain S•COR•E Z = Sand blast/carbozinc P = Marine Grade corrosion preventative finish S = Chain Container (fabric) -E = Meets European Machinery Directives

Model No.	Rated Capacity metric tons*	Pull to lift rated load		Load Chain size (mm)	Hand Chain O’Hauled to lift load 1 ft (0.3 m)		No. of chain falls	Hoist Net Weight (std. 10 ft. lift)	
		lb	kg		ft	m		lb	kg
VL2-005	1/2	55	25.0	5.0 x 15	25	7.6	1	20	9.0
VL2-010	1	73	33.2	6.3 x 19.2	28	8.5		36	16.4
VL2-015	1-1/2	74	33.6	7.1 x 21.2	57	17.4		45	20.4
VL2-020	2	76	34.5	8.0 x 24.2	73	22.3		50	22.7
VL2-030	3			7.1 x 21.2	112	34.1	2	52	23.6
VL2-050	5	85	38.6	9.0 x 27.2	181	55.2		94	42.6
VL2-080	8	90	40.9		272	82.9	3	150	68.2
VL2-100	10				362	110.3	4	188	85.5
VL2-150	15	2 x 90	2 x 41		2 x 272	2 x 82.9	6	395	179.5
VL2-200	20				2 x 362	2 x 110	8	485	220.4

* One metric ton equals 2200 lbs.

INSTALLATION

Prior to installing hoist, carefully inspect it for possible shipping damage. Hoists are supplied fully lubricated from the factory. Lubrication of the load chain is recommended before initial hoist operation.

WARNING

• Depending on model selected, hoist may weigh up to 485 lbs. (220 kg). If parts of the hoist are dropped, they can cause injury, death or property damage. Adequately support hoist during installation.

CAUTION

• Owners and users are advised to examine specific, local or other regulations, including ASME standards and/or OSHA Regulations which may apply to a particular type of use of this product before installing or putting hoist to use.

The VL2 manual chain hoist must be used in a vertical position to provide a straight line pull from top to bottom hook. The hoist must be positioned so that it does not contact the support members when in use. When operating in limited areas suitable lifting attachments or slings must be used to prevent hoist body and hand chain from being obstructed.

Initial Operating Checks

Operate hoist with a test load (10% of rated capacity) by raising and lowering this load several times. Verify brake operation with this light load prior to applying heavier loads.

NOTICE

• Each time a load is lifted, the operation of the brake should be checked by raising load slightly and stopping to ensure brake will hold load before continuing to lift.

Familiarize operators and personnel responsible for hoist installation and service with ASME B30.16 specifications and this manual prior to placing unit into service. All requirements of this specification, including testing should be met before approving hoist for operation.

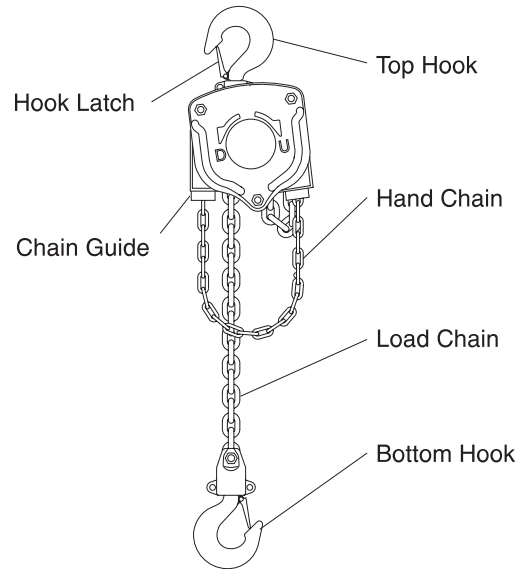

(Dwg. MHP0436)

Installing Chain Container

Refer to Dwg. MHP0321 on page 19. Position chain container to ensure minimum contact with handchain. On larger CC-8 and CC-9 style chain containers which use S-Hooks to support chain container, ensure hook ends are bent closed.

OPERATION

The four most important aspects of hoist operation are:

1. Follow all safety instructions when operating hoist.
2. Allow only personnel trained in safety and operation of this hoist to operate hoist.
3. Subject each hoist to a regular inspection and maintenance procedure.
4. Be aware of the hoist capacity and weight of load at all times.

WARNING

• Hoist is not designed or suitable for lifting, lowering or moving persons. Never lift loads over people.

Hoist Operation

When facing hand chain side of hoist:

Pull down on right hand chain (clockwise) to raise load.

Pull down on left hand chain (counterclockwise) to lower load.

On 15 and 20 ton hoists, use two operators, one on each of the two hand chains. To keep the load chain centered in the block assemblies, operate hoist units simultaneously and at the same speed. An equal amount of unloaded chain must be maintained under each hoist body.

WARNING

• Do not allow load chain, on 15 and 20 ton hoists, to accumulate on one side (under one hoist body). Excessive loading to load chain anchor may occur resulting in a falling load which can cause death, injury or property damage.

NOTICE

- The clicking sound of the pawl on the ratchet gear is normal when a load is being raised.

Storing the Hoist

1. Always store hoist in a no load condition.
2. Wipe off all dirt and water.
3. Oil the chain, hook pins and hook latch pins.
4. Hang in a dry place.
5. Before returning hoist to service follow instructions for Hoists not in Regular Service in “INSPECTION” section.

INSPECTION



WARNING

- All new, altered or modified equipment should be inspected and tested by personnel trained in safety, operation and maintenance of this equipment to ensure safe operation at rated specifications before placing equipment in service.

Frequent and periodic inspections should be performed on equipment in regular service. Frequent inspections are visual examinations performed by operators or service personnel and include observations made during routine equipment operation. Periodic inspections are thorough inspections conducted by personnel trained in the safety, operation and maintenance of this equipment. ASME B30.16 states inspection intervals depend upon the nature of the critical components of the equipment and severity of usage.

Careful inspection on a regular basis will reveal potentially dangerous conditions while still in the early stages, allowing corrective action to be taken before the condition becomes dangerous.

Deficiencies revealed through inspection, or noted during operation, must be reported to designated personnel trained in safety, operation and maintenance of this equipment. A determination as to whether a condition constitutes a safety hazard must be decided, and the correction of noted safety hazards accomplished and documented by written report before placing the equipment in service.

Records and Reports

Inspection records, listing all points requiring periodic inspection should be maintained for all load bearing equipment. Written reports, based on severity of service, should be made on the condition of critical parts as a method of documenting **periodic** inspections. These reports should be dated, signed by the person who performed the inspection, and kept on file where they are readily available for review.

NOTICE

- The external placement of coded marks on equipment identifying completed inspections and operationally certified equipment is an acceptable method of documenting periodic inspections in place of written records.

Load Chain Reports

Records should be maintained documenting the condition of load chain removed from service as part of a long-range load chain inspection program. Accurate records will establish a relationship between visual observations noted during frequent inspections and the actual condition of the load chain as determined by periodic inspection methods.

Frequent Inspection

The Manual Chain Hoist should be inspected at the beginning of each shift. Visual inspections should also be conducted during regular service for any damage or evidence of malfunction which appears between regular inspections.

1. OPERATION. Check for visual signs or abnormal noises which could indicate a potential problem. Do not operate a hoist unless the chain feeds through the hoist and hook block smoothly. Listen for “clicking”, binding or malfunctioning. The clicking sound of the pawl on the ratchet gear is normal when a load is being raised. If chain binds, jumps, or is excessively noisy, clean and lubricate the chain. If problem persists, replace the chain. Do not operate the hoist until all problems have been corrected. Check that hand chain moves freely and without binding or excessive drag. Hook should stop moving when hand chain stops moving.
2. HOOKS. Check for wear or damage, increased throat width, bent shank or twisting of hook. Replace hooks that exceed the throat opening discard width (15%) shown in Table 1 refer to Dwg. MHP0040 on page 6, or exceed a 10° twist refer to Dwg. MHP0111 on page 7. If hook latch snaps past tip of hook, hook is sprung and must be replaced. Check hook support bearings for lubrication and damage. Check hooks swivel easily and smoothly. Repair or lubricate as necessary.

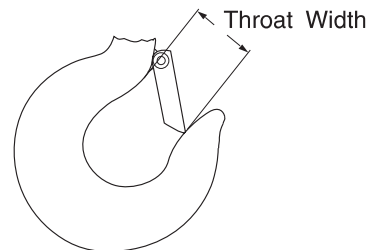

(Dwg. MHP0040)

Table 1: Hook Throat Dimension

Model No.	Throat Width		Discard Width	
	in.	mm	in.	mm
VL2-005	1.22	31	1.4	35.6
VL2-010	1.33	34	1.54	39.1
VL2-015	1.5	38	1.72	43.7
VL2-020	1.61	41	1.86	47.2
VL2-030	1.85	47	2.12	54
VL2-050	2.01	51	2.31	58.6
VL2-080	2.8	71	3.21	81.6
VL2-100				
VL2-150	3.54	90	4.07	103.5
VL2-200				

- HOOK LATCHES. Check operation of hook latches. Replace if broken or missing.
- CHAIN. Refer to Dwg. MHP0102 on page 7. Examine each link for bending, cracks in weld areas or shoulders, transverse nicks and gouges, weld splatter, corrosion pits, striation (minute parallel lines) and chain wear, including bearing surfaces between chain links. Replace a chain that fails any of the inspections. Check lubrication and lubricate if necessary. Refer to "Load Chain" in "LUBRICATION" section.

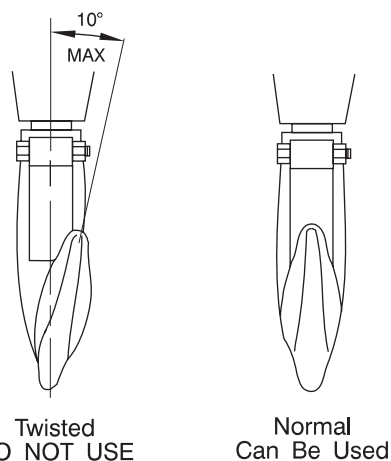

(Dwg. MHP0111)

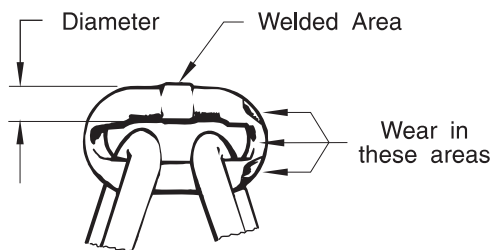

(Dwg. MHP0102)

CAUTION

• The full extent of chain wear cannot be determined by visual inspection. At any indication of chain wear inspect chain and load sheave in accordance with instructions in "Periodic Inspection."

• A worn load chain may cause damage to load sheave. Inspect load sheave and replace if damaged or worn.

- LOAD CHAIN REEVING. Refer to Dwg. MHP0042 on page 9. Make sure welds on standing links are away from load sheave. Reinstall chain if necessary. Make sure chain is not capsized, twisted or kinked. Adjust as required.

Periodic Inspection

According to ASME B30.16, frequency of periodic inspection depends on the severity of usage:

NORMAL	HEAVY	SEVERE
yearly	semiannually	quarterly

Disassembly may be required for HEAVY or SEVERE usage. Keep accumulative records of periodic inspections to provide a basis for continuing evaluation. Inspect all items in "Frequent Inspection." Also inspect the following:

- FASTENERS. Check rivets, capscrews, nuts, cotter pins and other fasteners on hooks, hoist body and chain bucket, if used. Replace if missing and tighten or secure if loose.
- ALL COMPONENTS. Inspect for wear, damage, distortion, deformation and cleanliness. If external evidence indicates the need, disassemble. Check gears, shafts, bearings, sheaves, chain guides, springs and covers. Replace worn or damaged parts. Clean, lubricate and reassemble.
- HOOKS. Inspect hooks for cracks. Use magnetic particle or dye penetrant to check for cracks. Inspect hook retaining parts. Tighten, repair or replace if necessary. Refer to the latest edition of ASME B30.10 (Hooks) for additional hook inspection information.
- CHAIN SHEAVES. Check for excessive wear or damage. Replace if necessary.
- BRAKES. Ensure proper operation. Brake must hold hoist rated capacity. If load test indicates the need, disassemble. Brake discs must be free of excess oil, any grease, unglazed, uniform in thickness and at least 5/64 in. (2 mm) thick. Check all other brake surfaces for wear, deformation or foreign deposits. Inspect pawl brake. Teeth of ratchet gear should be undamaged, and should stop gear rotation in the counterclockwise direction. Check pawl spring for damage. Clean and replace components as necessary.
- SUPPORTING STRUCTURE. If a permanent structure is used, inspect for continued ability to support load.
- LABELS AND TAGS. Check for presence and legibility. Replace if necessary.
- END ANCHOR. Ensure end anchor on chain hoist is engaged and unbent. Repair if damaged, replace if missing. Refer to "Attaching End of Load Chain" in "MAINTENANCE" section.
- LOAD CHAIN. Measure chain for stretching by measuring across five link sections all along chain. Refer to Dwg. MHP0041 on page 8 and Table 2. When any five links in the working length reach or exceed discard length shown in Table 2, replace entire chain. Always use a genuine **Ingersoll-Rand** replacement chain.

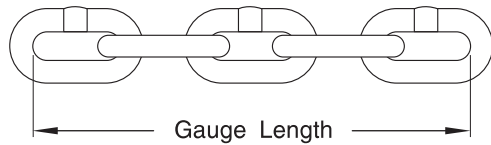

(Dwg. MHP0041)

Table 2: Load Chain Length Inspection

Model No.	Part No.	Chain Size	Normal Length		Discard Length	
		mm	in.	mm	in.	mm
VL2-005	LCCF005	5.0 x 15	2.95	75.0	3.03	77.0
VL2-010	LCCF010	6.3 x 19.2	3.76	95.5	3.85	97.9
VL2-015	LCCF015	7.1 x 21.2	4.17	106.0	4.28	108.7
VL2-020	LCCV020	8.0 x 24.2	4.72	120.0	4.84	123.0
VL2-030	LCCF015	7.1 x 21.2	4.17	106.0	4.28	108.7
VL2-050	LCCF025	9.0 x 27.2	5.35	136.0	5.47	139.0
VL2-080						
VL2-100						
VL2-150						
VL2-200						

Note: Nickel Plated load chain for the VL2 is designated by “ND” at the end of the part number.

Hoists not in Regular Service

1. A hoist that has been idle for a period of one month or more, but less than one year should be given an inspection conforming with requirements of “Frequent Inspection” before being placed in service.
2. A hoist that has been idle for a period of more than one year should be given a complete inspection conforming with requirements of “Periodic Inspection” before being placed in service.
3. Standby hoists should be inspected at least semiannually in accordance with requirements of “Frequent Inspection.” In abnormal operating conditions equipment should be inspected at shorter intervals.

TROUBLESHOOTING

This section provides basic troubleshooting information. Specific causes to problems are best identified by thorough inspections performed by personnel instructed in safety, operation and maintenance of this equipment. The chart below provides a brief guide to common hoist symptoms, probable causes and remedies.

Symptom	Cause	Remedy
Hoist will not lift load.	Hoist is overloaded.	Reduce load to within hoist rated capacity.
Hoist will not hold load.	Brake may be slipping.	Inspect brake. Replace brake discs or repair brake as described in the “MAINTENANCE” section.
	Hoist is overloaded.	Reduce load to within hoist rated capacity.
Load Chain Binds.	Damaged load chain, pinion shaft, gears or sheaves.	Disassemble hoist, inspect and repair or replace damaged components.
	Load chain not installed properly (twisted, kinked or “capsized”).	Remove load chain and re-install.
Hand Chain Binds.	Damaged hand chain, hand chain wheel, pinion shaft, gears, load chain, sheaves.	Disassemble hoist, inspect and repair or replace damaged components.
	Hand chain not installed properly (twisted or kinked).	Remove load chain and re-install.
Load Hook Latch does not work.	Latch broken.	Replace hook latch.
	Load hook bent or twisted.	Inspect load hook as described in “INSPECTION” section. Replace if necessary.

LUBRICATION

General

Thread lubricant or an anti-seize compound use is recommended for threaded shafts, capscrews and nuts. Unless otherwise stated, remove old lubricant, clean part with an acid free solvent and apply a new coating of lubricant to part before assembly.

Gears (11 and 14)

Remove U-nuts (40), on opposite side of hoist as the hand chain, and remove gear cover (17) and support plate (16). Remove old grease and replace with new. For temperatures -20° to 50° F (-29° to 10° C) use EP 1 grease or equivalent. For temperatures 30° to 120° F (-1° to 49° C) use EP 2 grease or equivalent.

Load Chain

WARNING

- Failure to maintain clean and well lubricated load chain may result in chain failure causing injury, death or substantial property damage.

1. Lubricate each link of chain weekly. Apply new lubricant over existing layer.
2. In severe applications or corrosive environments, lubricate frequently than normal.
3. Lubricate hook and hook latch pivot points with same lubricant used on load chain.
4. To remove rust or abrasive dust build-up, clean chain with an acid free solvent. After cleaning lubricate chain.
5. Use **Ingersoll-Rand LUBRI-LINK-GREEN®** or a SAE 50 to 90 EP oil.

MAINTENANCE

WARNING

- Never perform maintenance on hoist while it is supporting a load.
- Before performing maintenance, tag hoist:
WARNING - DO NOT OPERATE - EQUIPMENT BEING REPAIRED.
- Only allow personnel trained in operating and servicing this product to perform maintenance.
- After performing maintenance on the hoist, test to 125% of its rated capacity before returning to service. Testing to more than 125% of rated capacity might be required to comply with standards and regulations set forth in areas outside of the USA.

Installing New Load Chain

WARNING

- To prevent a falling load which can cause death, injury or property damage, hook (42) must be on left fall of load chain (47) and right fall must be attached to hoist body with end anchor (21 and 22). Right and left are designated when viewed from hand chain side of hoist.

NOTICE

- Do not remove old load chain from hoist. Old load chain can be used to install new load chain.

1. Remove end of load chain from end anchor (21 and 22).
2. Make a “C” link in new load chain by grinding through one side of end link. On 1/2 to 2, 8, 15 and 20 ton hoists the load chain must have an even number of links, not counting the “C” link, to avoid twisting. On 3, 5 and 10 ton hoists the load chain must have an odd number of links, not counting the “C” link, to avoid twisting.
3. Using a “C” link, join old load chain to new load chain. If old load chain was installed correctly, the “C” link assures end link of new load chain will be correctly reeved through the hoist. Be sure welds of “standing” links on new load chain are facing away from hoist load sheave(s) (6). Refer to Dwg. MHP0042 on page 9.
4. Run new load chain to its anchor point. On smaller units, use hand chain (46) to move load chain. On larger units, load chain (47) installation can be speeded up by unscrewing U-nuts (40), removing gear cover (17), support plate (16) and taking out 2nd gear set (14). With gear set (14) removed, load chain (47) can be pulled by hand through hoist body and hook blocks.

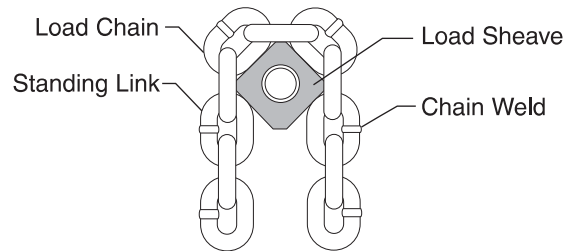

(Dwg. MHP0042)

5. Remove “C” link and old load chain.
6. Anchor load chain:
 - a. On 1/2 to 2 ton and 8 ton hoists, load end of load chain (47) is attached to bottom hook block.
 - b. On 3, 5 and 10 ton hoists load end of load chain (47) is attached to top hook frame.
 - c. On 15 and 20 ton hoists, load end of load chain (47) to attached to end anchor (21 and 22) of second hoist body.For information on connecting unloaded end of load chain (47) refer to “Attaching End of Load Chain” section.

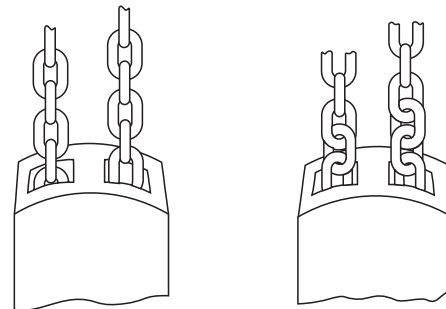

Appearance of chain that is Not Twisted

Appearance of chain that Is Twisted

(Dwg. MHP0020)

7. Check for the following:
 - a. Load chain did not become twisted, when reeving load chain (47) between idler sheaves on the bottom and top hook assembly. Refer to Dwg. MHP0020 on page 9.
 - b. Load chain (47) is reeved between load sheave (6) and chain guides (7).

Capsized Hook

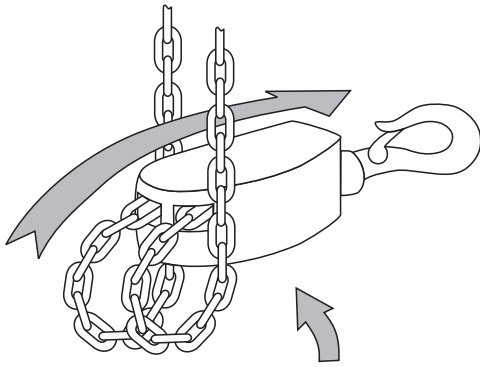

Make certain the bottom block has NOT been flipped through the chain falls

(Dwg. MHP0043)

Attaching End of Load Chain

Refer to Dwg. MHP0410 on page 10.

1. Push end pin (20) "in", towards end spring (19). Remove end anchor A (21).
2. Slide end link of load chain (47) on end anchor A (21) shaft.
3. Place end anchor A (21) shaft into end anchor B (22) guide hole.
4. Reinstall end anchor A (21) on end pin (20). Depress and align end pin (20) in side plate 1 (1) hole. When released end pin (20) should spring into position and slide into hole in side plate (1). Ensure load chain (47) is not twisted, kinked or "capsized." Refer to Dwg. MHP0043 on page 10.
5. Connect other end of load chain (47) as described in "Installing New Load Chain" section.

Brake Adjustment

1. Unscrew nuts (40) and remove wheel cover (38) so that handwheel (31) is exposed.
2. Remove cotter pin (34) and tighten pinion nut (33) (clockwise). Hold load chain (47), if necessary, to keep pinion shaft (13) from rotating.
3. Back off pinion nut (33) approximately 1/8th of a turn (counterclockwise) and reinsert cotter pin (34).

Overload Clutch Adjustment

1. Suspend the **VL2** hoist.
2. Remove wheel cover (38), cotter pin (34), pinion nut (33) and washer (32).
3. Apply adjusting load shown in Table 3 to hoist.
4. Remove all slack from load chain.
5. Pull on hand chain to lift load approximately 2 feet (0.6 m) off the floor.
6. Using overload clutch adjusting socket part number 71112064 (refer to Dwg. MHP0225 on page 10) adjust overload clutch to required setting.
 - a. Tightening nut (82) will increase clutch overload limit.
 - b. Loosen nut (82) to decrease clutch overload limit.

Overload clutch should begin to slip with loads shown in Table 3.
7. When desired clutch overload limit has been achieved bend one of the outer tabs on washer (81) into a slot in nut (82). Install washer (32) and pinion nut (33).
8. Tighten pinion nut (33).

Table 3: Overload Clutch Test Loads

Model No.	Adjustment Load (150% of rated capacity)	
	lbs.	kgs.
VL2-005	1,650	750
VL2-010	3,300	1,500
VL2-015	4,950	2,250
VL2-020	6,600	3,000
VL2-030	9,900	4,500
VL2-050	16,500	7,500
VL2-080	26,400	12,000
VL2-100	33,000	15,000
VL2-150	49,500	22,500
*VL2-200	33,000 each hoist	15,000 each hoist

* Each hoist body must be tested separately.

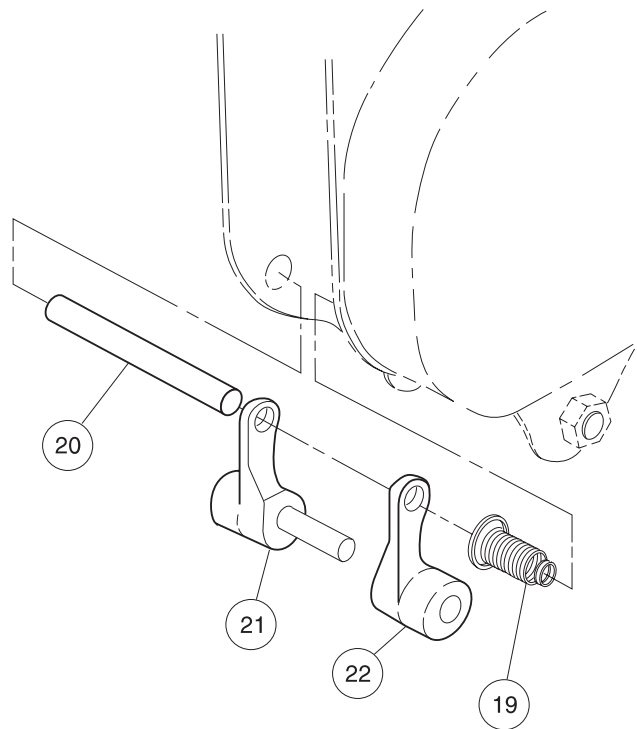

(Dwg. MHP0410)

NOTICE

• Proper adjustment of overload clutch requires use of a special tool (Part Number 71112064). Refer to Dwg. MHP0225 on page 10.

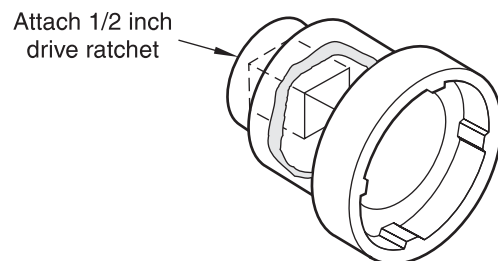

(Dwg. MHP0225)

General Disassembly

The following instructions provide necessary information to disassemble, inspect, repair, and assemble the hoist. Hoist assembly parts drawings are provided in “PARTS” section.

If a hoist is being completely disassembled for any reason, follow the order of the topics as they are presented. It is recommended that all maintenance work be performed on a bench.

In the process of disassembling the hoist, observe the following:

1. Never disassemble hoist any further than is necessary to accomplish needed repair. A good part can be damaged during the course of disassembly.
2. Never use excessive force when removing parts. Tapping gently around the perimeter of a cover or housing with a soft hammer, for example, is sufficient to break the seal.
3. Do not apply heat to a part to free it for removal unless part being heated is already worn or damaged beyond repair and no additional damage will occur to other parts. In general, the hoist is designed to permit easy disassembly and assembly. Use of heat or excessive force should not be required.
4. Keep work area as clean as practical, to prevent dirt and other foreign matter from getting into bearings or other moving parts.
5. When grasping a part in a vise, always use leather-covered or copper-covered vise jaws to protect the surface of the part and help prevent distortion. This is particularly true of threaded members, machined surfaces and housings.
6. Do not remove any part which is press fit in or on a subassembly unless removal of that part is necessary for repairs or replacement.

Hoist Disassembly

Brake Disc Replacement

1. Unscrew U-nuts (40). Remove wheel cover (38).
2. Lift hand chain guides (35) off stay bolts on side plate 1 (1). Remove hand chain (46) from handwheel (31).
3. Remove cotter pin (34), unscrew pinion nut (33) and remove washer (32).
4. Remove handwheel (31) by holding load chain (46) and rotating handwheel (31) counterclockwise until it can be lifted off pinion shaft (13).
5. Remove brake cover (30) and brake disc A (27).
6. Remove ratchet gear (29) and brake disc B (28).

Overload Clutch Disassembly

1. Refer to previous instructions for removal of wheel cover (38).
2. Use a small punch to bend tab on washer (81) out of slot in nut (82).
3. Firmly grip outside of overload clutch assembly then use clutch adjusting socket part number 71112064 to remove nut (82) from supporter (78).
4. Separate remaining parts of overload clutch assembly.

Cleaning, Inspection and Repair

Use the following procedures to clean, inspect and repair components of the hoist.

Cleaning

Clean all hoist component parts in an acid free solvent (except for brake discs). Use of a stiff bristle brush will facilitate removal of accumulated dirt and sediments on gears and frames. Dry each part using low pressure, filtered compressed air.

Inspection

All disassembled parts should be inspected to determine their fitness for continued use. Pay particular attention to the following:

1. Inspect all gears for worn, cracked, or broken teeth.
2. Inspect shafts for ridges caused by wear. If ridges caused by wear are apparent on shafts, replace shaft.
3. Inspect all threaded items and replace those having damaged threads.
4. Measure thickness of brake discs. If brake discs do not have uniform thickness or are less than 5/64 in. (2 mm) thick replace brake discs.

Repair

Actual repairs are limited to removal of small burrs and other minor surface imperfections from gears and shafts. Use a fine stone or emery cloth for this work.

1. Worn or damaged parts must be replaced. Refer to applicable parts listing for specific replacement parts information.
2. Inspect all remaining parts for evidence of damage. Replace or repair any part which is in questionable condition. The cost of the part is often minor in comparison with the cost of redoing the job.
3. Smooth out all minor nicks, burrs or galled spots on shafts, bores, pins and bushings.
4. Examine all gear teeth carefully, remove nicks and burrs.
5. Polish edges of all shaft shoulders to remove small nicks which may have been caused during handling.
6. Remove all nicks and burrs caused by lockwashers.

Hoist Assembly



• **The brake will not operate properly if there is too much oil on brake discs (27 and 28). Excessive oil or grease on brake components could cause load to slip.**

1. Dip replacement brake discs (27 and 28) in ISO VG32 hydraulic oil or SAE 10 oil for two seconds. Wipe off excess oil.
2. Place brake disc B (28) over hub (26). Brake disc B (28) has a smaller outside diameter than brake disc A (27).
3. Install ratchet gear (29) on hub (26) so recessed face fits over brake disc B. Teeth of ratchet gear (29) must engage pawl (24). Ratchet gear (29) should not rotate counterclockwise and should “click” when rotated clockwise.
4. Place brake disc A (27) on ratchet gear (29).
5. Place brake cover (30) over stay bolts on side plate 1 assembly (1).
6. With brake surface of handwheel (31) towards brake disc A (27), place handwheel (31) on pinion shaft (13). Rotate handwheel (31) clockwise until clicking occurs. Hold load chain (47) if necessary.
7. Place washer (32) over pinion (13). Install pinion nut (33) and cotter pin (34) using “Brake Adjustment.”

8. Install hand chain (46) in handwheel (31). Make sure hand chain (46) is seated properly.
9. Install "looped" end of a hand chain guide (35) over each of the two upper stay bolts on side plate 1 (1). Hand chain guides (35) must be positioned like two "Ls" pointing inward ("L _J").
10. Place wheel cover (38) over stay bolts. Free ends of chain guides (35) go on outside of wheel cover (38).
11. Install U-nuts (40).

Gears (14)

On 1-1/2, 3, 5, 8, 10, 15 and 20 ton units, each hoist body must have one gear without a "circle" and one gear with a "circle." The 1/2, 1 and 2 ton units do not use gears with a circle. Refer to Dwg. MHP0044 on page 12.

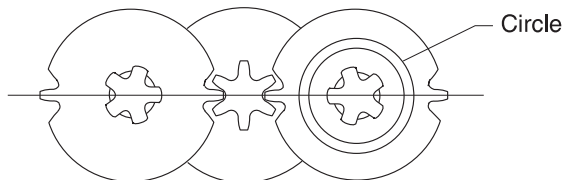

(Dwg. MHP0044)

Note: The 1/2 ton hoist has a center pinion gear with only five teeth.

Hand Chain Adjustment or Replacement



• When cutting weld side of a hand chain link, do not cut or nick opposite side. A damaged link must be replaced to prevent premature failure. A falling hand chain can cause injury.

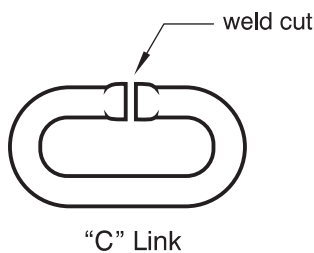

(Dwg. MHP0016)

1. To create a "C" link, cut welded side of link with a hacksaw. Clamp one side of "C" link in a vise and bend it open by using a pliers to grip the exposed part of link. Refer to Dwgs. MHP0014 and MHP0016 on page 12.

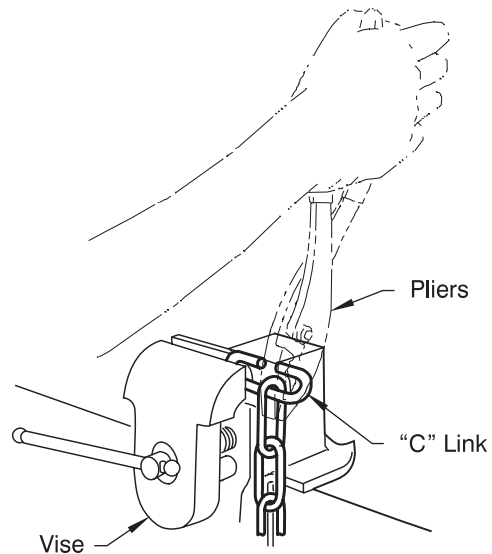

(Dwg. MHP0014)

2. If you are replacing the hand chain, disconnect it at the "C" link and carefully remove the hand chain.
3. When replacing a hand chain, cut a length 2 times the required hand chain drop plus about one foot (305 mm). For adjustments, remove or add a length of chain twice the difference in hand chain height. To prevent hand chain from twisting, maintain an even number of links, by removing or adding an even number of links.
4. If you are replacing hand chain, run new hand chain up through left hand chain guide, around handwheel, making sure hand chain is seated in handwheel pockets, and back down through right hand chain guide.
5. Connect hand chain ends with 'C' link(s), making total number of links even, and bend 'C' link(s) shut.
6. Make sure hand chain is not twisted. If twisted, untwist or open a 'C' link and remove one hand chain link if necessary.

Overload Clutch Assembly

1. Install supporter (78) on pinion shaft (13). Set cone wheel (79) in handwheel (31). Install spring (94) and ball (93) in hole in handwheel. Position parts on supporter (78) making sure ball and spring remain in place. Notch in supporter must line up with ball and spring hole.
2. Install cone spring (80) with dished surface towards brake discs (27) and (28).
3. Install washer (81) on hub of supporter (78) so tab locates in supporter slot. Outer tabs on washer (81) must face outward away from cone spring (80).
4. Install nut (82) on supporter (78) until finger tight.
5. Install washer (32) and nut (33) on pinion shaft (13).
6. Adjust overload clutch as described in the "Overload Clutch Adjustment" section.

Load Test

Prior to initial use, all new, extensively repaired, or altered hoists shall be load tested by or under the direction of a person trained in operation and maintenance of this hoist, and a written report furnished confirming rating of hoist. Test hoist to 125% of rated hoist capacity. Testing to more than 125% is required to test overload clutch and may be necessary to comply with standards and regulations set forth in areas outside of the USA.

15 AND 20 TON TOP AND BOTTOM HOOK ASSEMBLY DRAWING

15 ton VL2 Top and Bottom Hook

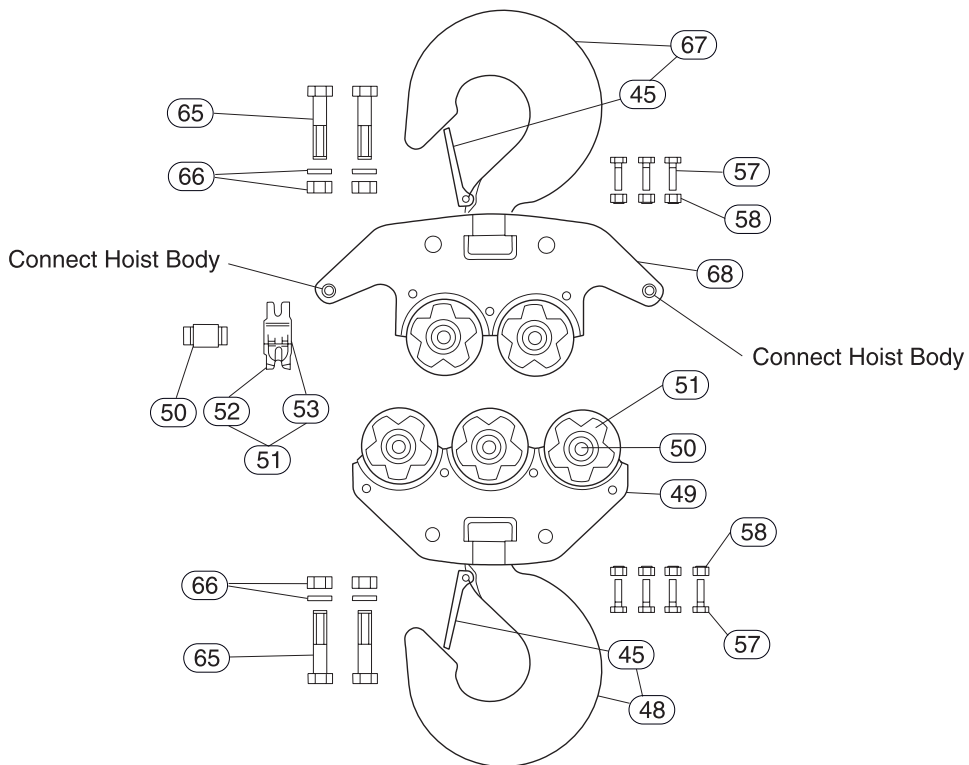

(Dwg. MHP0046)

20 ton VL2 Top and Bottom Hook

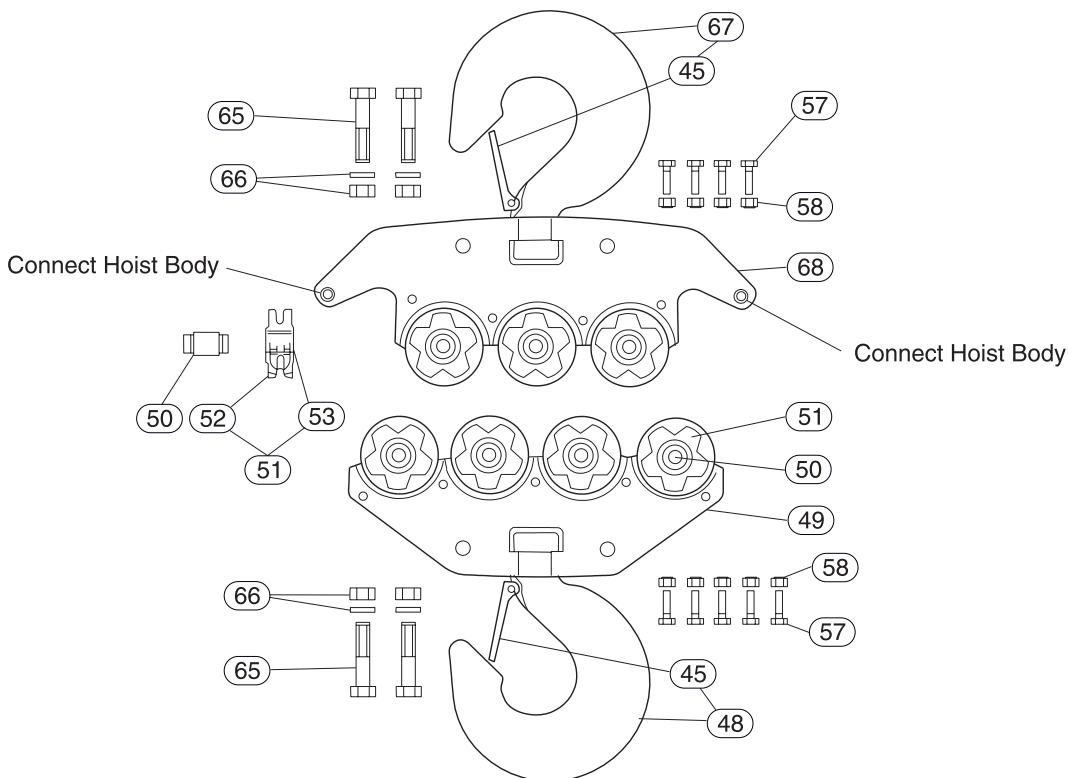

(Dwg. MHP0047)

HOIST ASSEMBLY PARTS DRAWING

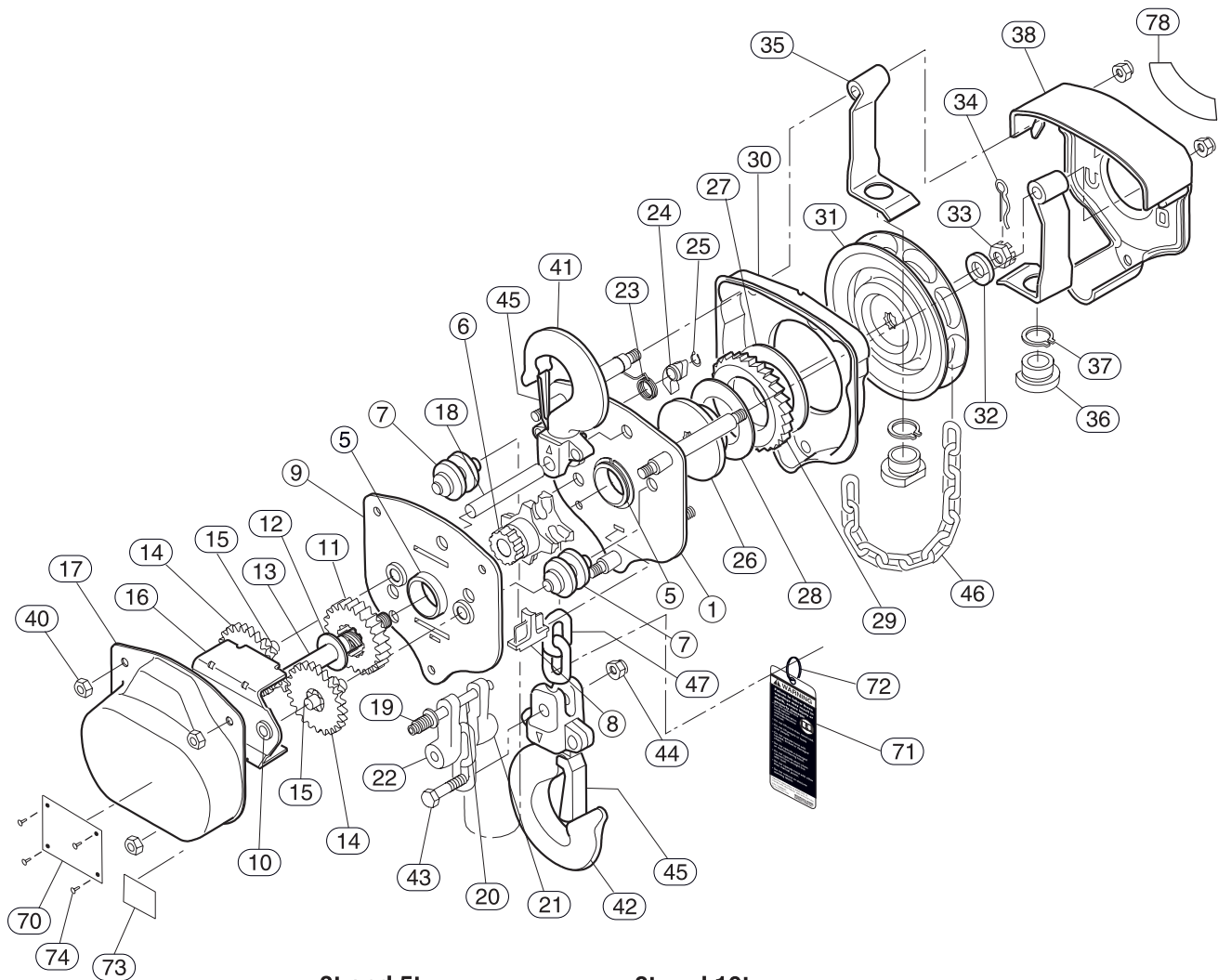

**3t and 5t
Top Hook**

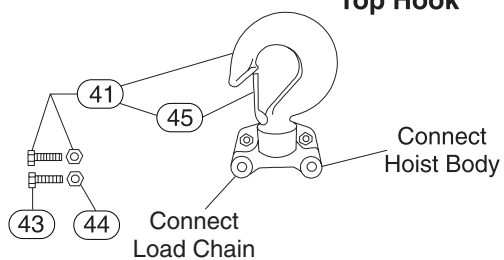

**8t and 10t
Top Hook**

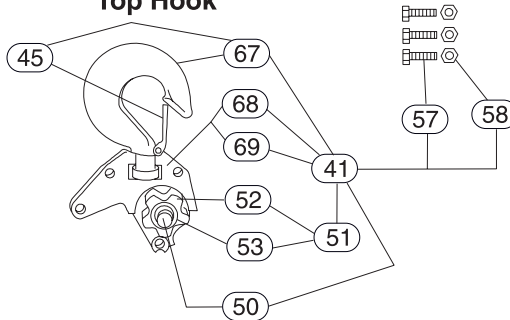

**3t, 5t and 8t
Bottom Hook**

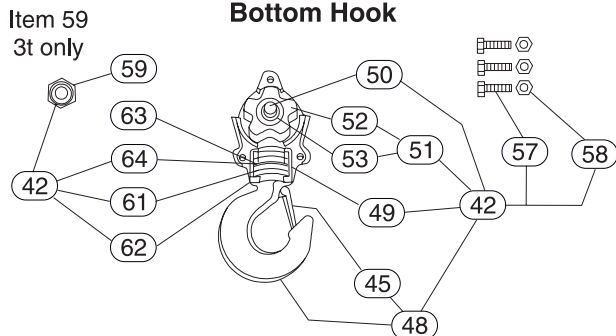

**10 ton
Bottom Hook**

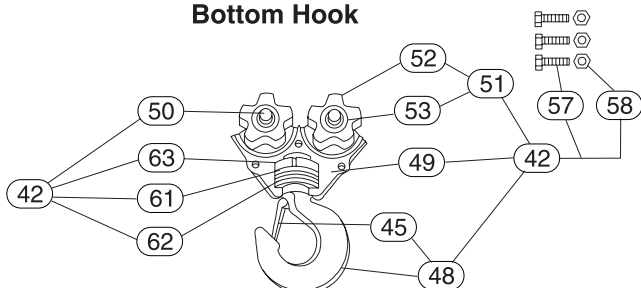

(Dwg. MHP0045)

HOIST ASSEMBLY PARTS LIST

ITEM NO.	DESCRIPTION OF PART	QTY. TOTAL	PART NO.					
			1/2 ton	1 ton	1-1/2 ton	2 ton	3 ton	5, 8, 10, 15 & 20 ton
1	Side Plate 1 Assembly (Incl's item 5)	1(2)	71029169	71029201	71029177	71029185	71029177	71029193
5	Needle Bearing w/Retainer Ring	2(4)	2372782	2372824		2372869	2372824	2372903
6	Load Sheave	1(2)	2372784	2372826	2372852	2372871	2372852	2372905
7	Load Chain Guide	2(4)	2372785	2372827		2372872	2372827	2372872
8	Chain Stripper	1(2)	2372786	2372828		2372873	2372828	2372873
9	Side Plate 2 Assembly	1(2)	2372787	2372829	2372853	2372874	2372853	2372906
10	Gear Bushing	4(8)	2372788			2372875	2372788	2372875
11	1st Gear	1(2)	2372789	2372830	2372854	2372876	2372854	2372907
12	Pinion Washer	1(2)	2372790	—				
13	Pinion Shaft	1(2)	2372791	2372831		2372877	2372831	2372877
14	2nd Gear Set (Plain/Plain)	1(2) Set(s)	71490270	71490288	—	71490304	—	
	2nd Gear Set (Plain/Circle)		—		71490296	—	71490296	71490312
15	3rd Gear	2(4)	2372793	2372833		2372879	2372833	2372909
16	Support Plate	1(2)	2372794	2372834	2372856	2372880	2372856	2372910
17	Gear Cover	1(2)	2372795	2372835	2372857	2372881	2372857	2372911
18	Hook Pin	1(2)	2372796	2372836		2372882	2372836	2372912
19	End Spring	1(2)	2372797					
20	End Pin	1(2)	2372798	2372837		2372883	2372837	2372883
21	End Anchor A	1(2)	2372799	2372838		2372884	2372838	2372884
22	End Anchor B	1(2)	2372800	2372839		2372885	2372839	2372885
23	Spring	1(2)	2372801	2372840	2372858	2372886	2372858	2372913
24	Pawl	1(2)	2372802			2372887	2372802	2372887
25	Snap Link	1(2)	2372803			2372888	2372803	2372888
26	Hub	1(2)	2372804	2372841		2372889	2372841	2372889
• 27	Brake Disc	1 set	71112353			71112361	71112353	71112361
• 28								
29	Ratchet Gear	1(2)	2372807			2372891	2372807	2372891
30	Brake Cover	1(2)	2372808	2372842	2372859	2372892	2372859	2372914
31	Handwheel	1(2)	2372809	2372843	2372860	2372893	2372860	2372915
	Handwheel, Copper Plated*	1(2)	2372809-CP	2372843-CP	2372860-CP	2372893-CP	2372860-CP	2372915-CP
	Handwheel (Overload Clutch)	1(2)	Refer to page 19					
	Handwheel Assembly with Overload Clutch* (Incl's items 31 thru 34 and 78 thru 82)	1(2)						
	Handwheel Assembly with Overload Clutch, Copper Plated * (Incl's items 31 thru 34 and 78 thru 82)	1(2)						
32	Washer	1(2)	2372810					
33	Pinion Nut	1(2)	2372811					
34	Cotter Pin	1(2)	2372812					
35	Hand Chain Guide (2 piece)	2(4)	71026546	71026553		71026561	71026553	71026579
	Hand Chain Guide (1 piece)	1(2)	12901			9967	12901	9967
• 36	Nylon Ring	2(4)	71026595					
	Bushing*	2(4)	2982-1					
37	Snap Ring	2(4)	51398					
38	Wheel Cover	1(2)	71028955	71028963	71028971	71028989	71028971	71028997
	Wheel Cover *		12545-4	12545-3		12545-2	12545-1	12545
40	U-Nut	6(12)	2372814			2372895	2372814	2372895

HOIST ASSEMBLY PARTS LIST (CONTINUED)

ITEM NO.	DESCRIPTION OF PART	QTY. TOTAL	PART NO.					
			1/2 ton	1 ton	1-1/2 ton	2 ton	3 ton	5, 8, 10, 15 & 20 ton
• 41	Top Hook Set (Incl's Item 45 and items 43 and 44 on 3 ton hoists)	1	2372815	2372845	2372862	2372896	2372922	Refer to Parts List Continuation
	Top Hook Set, Copper Plated (Copper Plated Hook and Hook Frames)*		2372815-CP	2372845-CP	2372862-CP	2372896-CP	2372922-CP	
	Top Hook Set, Solid Bronze (Solid Bronze Hook and Copper Plated Hook Frames)*		2372815-SB	2372845-SB	2372862-SB	2372896-SB	2372922-SB	
• 42	Bottom Hook Set (Incl's item 45)	1	2372817	2372847	2372864	2372898	2372924	
	Bottom Hook Set, Copper Plated (Copper Plated Hook and Hook Frames)*		2372817-CP	2372847-CP	2372864-CP	2372898-CP	2372924-CP	
	Bottom Hook Set, Solid Bronze (Solid Bronze Hook and Copper Plated Hook Frames)*		2372817-SB	2372847-SB	2372864-SB	2372898-SB	2372924-SB	
• 43	Chain Bolt	1 (2)	Order Kit 71490684	Order Kit 71490692		Order Kit 71490700	Order Kit 71492201	
• 44	U-Nut	1 (2)						
• 45	Hook Latch for Regular and Copper Plated Hook	1	2372850	2372865	2372901	2372925		
	Hook Latch (Solid Bronze Hook)		51502	52377	52377	51202		
46	Hand Chain	As Req'd	HCCB005			HCCV020	HCCB005	HCCV020
	Hand Chain, Zinc Plated*		HCCB005ZP			HCCV020ZP	HCCB005ZP	HCCV020ZP
47	Load Chain	As Req'd	LCCF005	LCCF010	LCCF015	LCCV020	LCCF015	LCCF025
	Load Chain, Nickel Plated*		LCCF005ND	LCCF010ND	LCCF015ND	LCCF020ND	LCCF015ND	LCCF025ND
57	Yoke Bolt (Copper Plated and solid bronze only)	1	71069033	54560	71069033	Refer to Parts List Continuation		
58	Yoke Nut (Copper Plated and solid bronze only)	1	50852					
70	Model Label	1	Order Label Kit item 92					Refer to Parts List Continuation
71	Warning Tag	1(2)	Order Label Kit item 92					
72	Tag Ring	1(2)	50040					
73	Chain Installation Label	1(2)	Order Label Kit item 92					
74	Rivet	4	Use standard pop rivet					
75	Bolt*	1	71031314					
76	Washer*	1	12632					
77	Nut*	1	71061584					
78	Capacity Label	1	Order Label Kit item 92					
92	Label Kit (Incl's items 70, 71, 72 and 73)	1	71112437	71112445	71112452	71112460	71112478	Refer to Parts List Continuation

* S•COR•E (Spark and Corrosion Resistant) feature.

() Items 43 and 44 quantities in parenthesis are for 3 and 5 ton hoist, other quantities in parentheses are for 15 and 20 ton hoists, which use two manual chain hoist bodies.

• Recommended spare.

HOIST ASSEMBLY PARTS LIST (CONTINUED)

ITEM NO.	DESCRIPTION OF PART	QTY. TOTAL	PART NO.						
			3 ton	5 ton	8 ton	10 ton	15 ton	20 ton	
• 41	Top Hook Set (Incl's items 50, 51, 57, 58 and 65 thru 69)	1	Refer to Previous Parts List	2372938	2372954	2372966	71037089	71037097	
	Top Hook Set, Copper Plated (Copper Plated Hook)*			2372938-CP	2372954-CP	2372966-CP	71037089-CP	71037097-CP	
	Top Hook Set, Solid Bronze (Solid Bronze Hook)*			2372938-SB	2372954-SB	2372966-SB	71037089-SB	71037097-SB	
• 42	Bottom Hook Set (Incl's items 48, 49, 50, 51, 57, 58, 59, 61 thru 67)	1		2372940	2372956	2372968	71037105	71037113	
	Bottom Hook Set, Copper Plated (Copper Plated Hook)*			2372940-CP	2372956-CP	2372968-CP	71037105-CP	71037113-CP	
	Bottom Hook Set, Solid Bronze (Solid Bronze Hook)*			2372940-SB	2372956-SB	2372968-SB	71037105-SB	71037113-SB	
• 43	Chain Bolt	1 (2)		Order Kit 71490718			—		
• 44	U-Nut	1 (2)					—		
• 45	Hook Latch Kit for Regular and Copper Plated Hook	2		2372941	2372957	2372969	71029045		
	Hook Latch Kit (Solid Bronze Hook)			50597	50779		—		
48	Bottom Hook Only	1	2372928	2372944	2372960	2372972	71108815	71108823	
49	Bottom Frame	2	2372930	2372946	2372962	2372974	71029078	71029086	
	Bottom Frame, Copper Plated*		2372930-CP	2372946-CP	2372962-CP	2372974-CP	—		
50	Axle	See ()	2372931 (1)	2372947 (1)	2372947 (2)	2372947(3)	2372947 (5)	2372947 (7)	
51	Idler Sheave with Needle Bearing (Incl's items 52 and 53)	See ()	2372932 (1)	2372948 (1)	2372948 (2)	2372948 (3)	2372948 (5)	2372948 (7)	
52	Idler Sheave (no Bearing)	See ()	Order item 51						
53	Needle Bearing for Axle	See ()	2372933 (1)	2372949 (1)	2372949 (2)	2372949 (3)	2372949 (5)	2372949 (7)	
57	Yoke Bolt	See ()	2372783 (2)	2372825 (3)	2372870 (5)	2372904 (6)	71029136 (7)	71029136 (9)	
	Additional Yoke Bolt (Copper Plated and Solid Bronze only)*	2	54558	54561	—				
58	Yoke Nut	See ()	2372816 (2)	2372846 (3)	2372863 (5)	2372897 (6)	2372897 (7)	2372897 (9)	
	Additional Yoke Nut (Copper Plated and Solid Bronze only)*	2	54559	54562	—				
59	Nut	1	2372918	—					
60	Axle Washer	2	2373137	—					
61	Thrust Bearing	1	2372934	2372950	2372963	2372975	—		
62	Thrust Washer	1	2372935	2372951	2372964	2372976	—		
63	C-Link	2	2372936	2372952	2372965	2372977	—		
64	O-Link	1	2372937	2372953	—				
65	Bolt B (for Clevis)	4	—			71029102			
66	Nut and Washer (for item 65)	4	—			71029144			
67	Top Hook	1	—		2372958	2372970	71108815	71108823	
68	Top Hook Frame A	1	Not Sold Separately		2372959	2372971	71029227	71029129	
	Top Hook Frame A, Copper Plated*				2372959-CP	2372971-CP	—		
69	Top Hook Frame B	1			2372980	2372981	71029227	71029129	
	Top Hook Frame B, Copper Plated*				2372980-CP	2372981-CP	—		
70	Model Label	1(2)	Refer to Previous Parts List						
71	Warning Tag	1							
74	Rivet	4(8)							
78	Capacity Label	1							
92	Label Kit (incl's items 70 thru 73)	1							
			Order Label Kit item 92						
			Use standard pop rivet						
			Order Label Kit item 92						
			71112486	71112494	71112502	71112510	71112528		

* S•COR•E (Spark and Corrosion Resistant) feature.

() Items 43 and 44 quantities in parenthesis are for 3 and 5 ton hoist, other quantities in parentheses are for 15 and 20 ton hoists, which use two manual chain hoist bodies.

• Recommended spare.

HOIST OVERLOAD CLUTCH ASSEMBLY DRAWING AND PARTS LIST

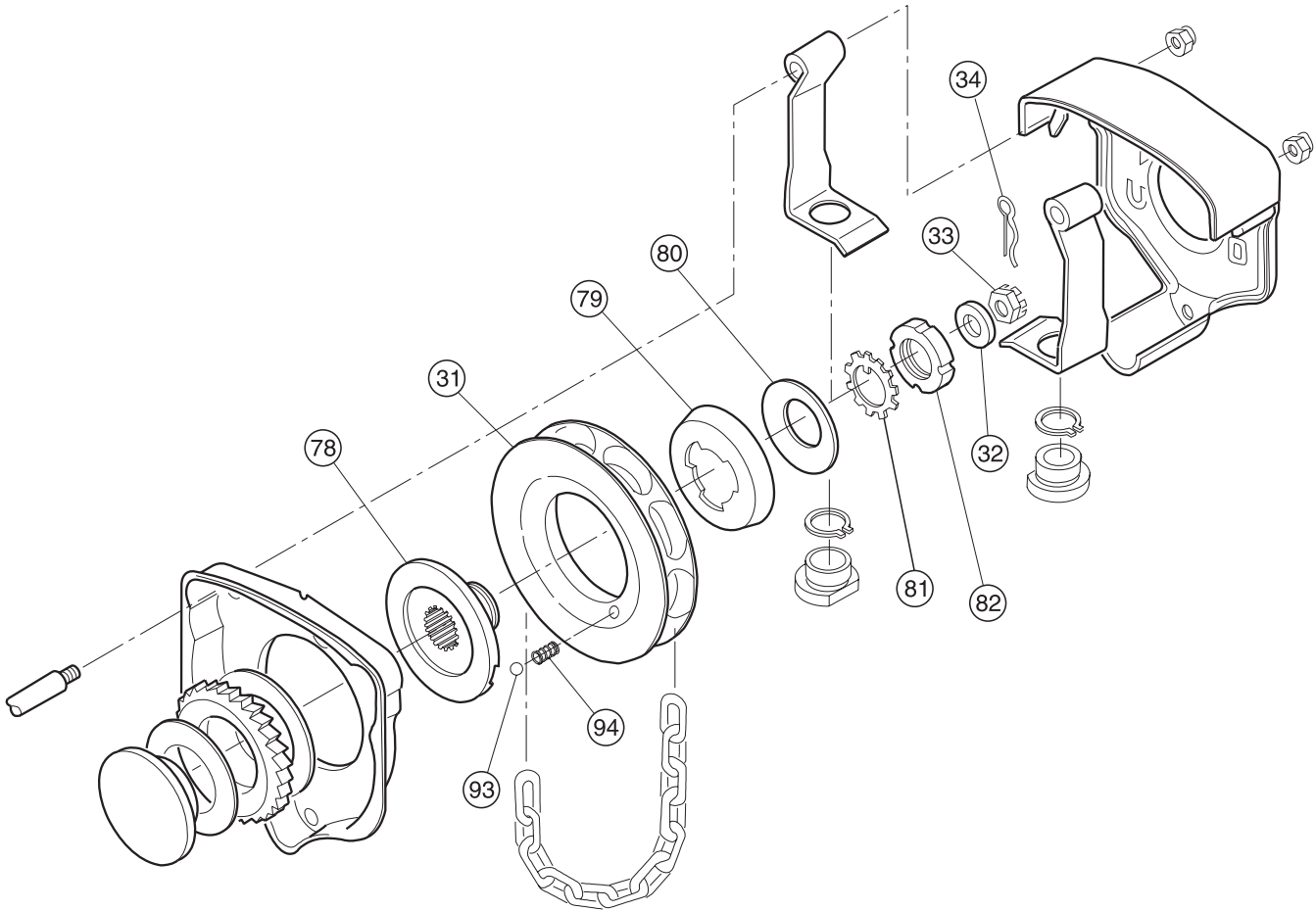

(Dwg. MHP0322)

Refer to Hoist Assembly Parts List on pages 15 and 16 for items shown on drawing.

ITEM NO.	DESCRIPTION OF PART	QTY. TOTAL	PART NUMBER					
			1/2 ton	1 ton	1-1/2 ton	2 ton	3 ton	5, 8, 10, 15 & 20 ton
31	Handwheel Assembly with Overload Clutch (Incl's items 31 thru 34, 78 thru 82, 93 and 94)	1(2)	71487052	71487060	71487078	71487086	71487078	71487094
	Handwheel Assembly with Overload Clutch, Copper Plated* (Incl's items 31 thru 34, 78 thru 82, 93 and 94)	1(2)	71487052-CP	71487060-CP	71487078-CP	71487086-CP	71487078-CP	71487094-CP
	Handwheel (Overload Clutch)	1(2)	71486872	71486880	71486898	71486906	71486898	71486914
	Handwheel, Copper Plated*	1(2)	71486872-CP	71486880-CP	71486898-CP	71486906-CP	71486898-CP	71486914-CP
78	Supporter	1	Not Sold Separately Order Item 31					
79	Cone Wheel	1						
80	Cone Spring	1						
81	Washer	1						
82	Nut	1						
93	Ball**	1						
94	Spring**	1						

* S•COR•E (Spark and Corrosion Resistant) feature.

** Refer to page 21 for VL2 Hoist Revisions.

() Quantities in parentheses are for 15 and 20 ton hoist, which use two manual chain hoist bodies.

CHAIN CONTAINER ASSEMBLY (OPTIONAL)

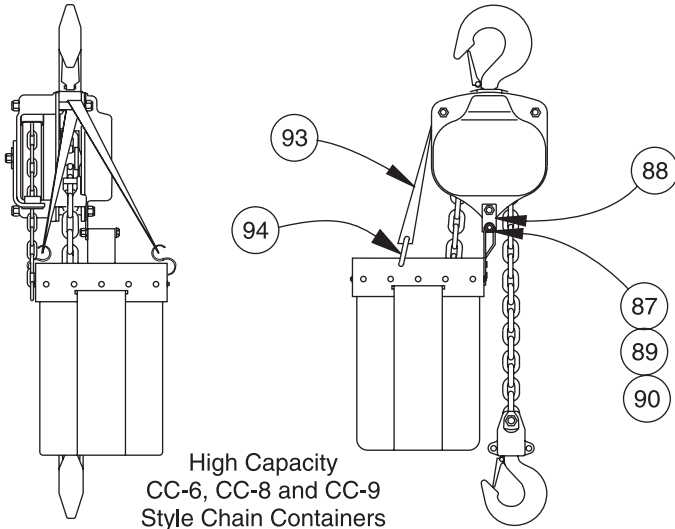
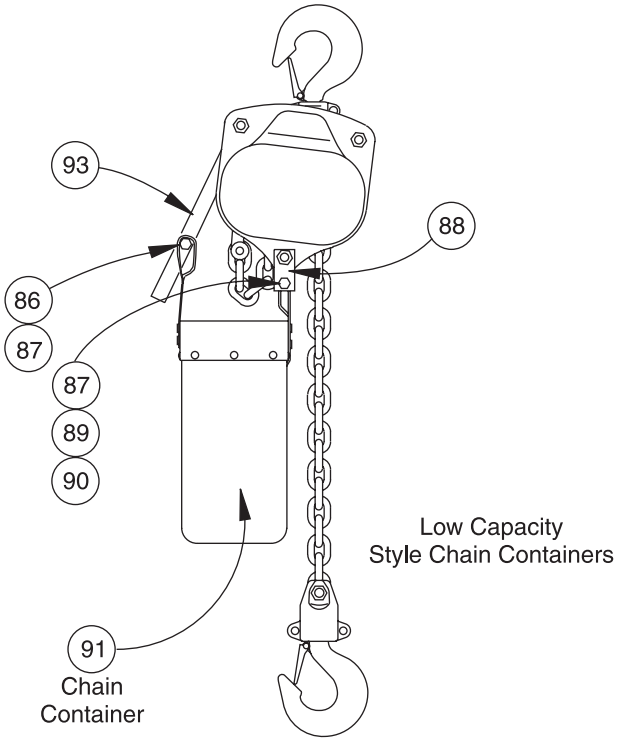
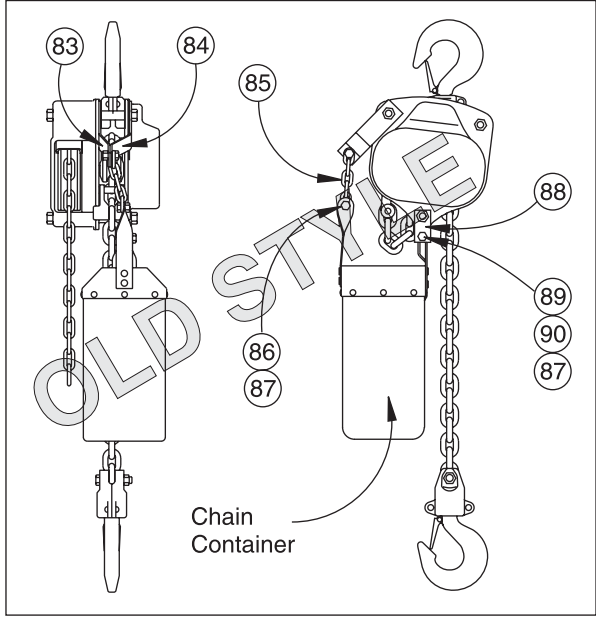

(Dwg. MHP0321)

ITEM NO.	DESCRIPTION OF PART	PART NUMBER			
		All Hoist Capacities			
		QTY. TOTAL	Low Capacity Chain Containers	QTY. TOTAL	High Capacity Chain Containers CC-6, CC-8 and CC-9
—	Bracket Kit	1	22863*	1	22864**
86	Capscrew	2	53972	2	53972
87	Nut	2	54171	2	54171
88	Bracket	1	12064-2	1	12064-2
89	Capscrew	2	71125413	1	71125413
90	Washer	5	53978	3	53978
91	Chain Container	1	Refer to Chain Container Chart	1	Refer to Chain Container Chart
93	Strap	1	22862	1	22865
94	S-Hook	—	—	2	52120

* Includes items 86 through 90 and 93.
 ** Includes items 86 through 90, 93 and 94.

Old Style

Parts for this style chain container assembly may be obsolete or out of production and may not be available.

ITEM NO.	DESCRIPTION OF PART	QTY. TOTAL	PART NUMBER						
			1/2 ton	1 ton	1-1/2 ton	2 ton	3 ton	5 ton	8, 10, 15 & 20 ton
—	Bracket Kit (Incl's items 83 and 86 through 90)	1	12586-1				12586-2	12586-3	12586-4
83	Bracket	1	8725-3						
84	Bracket	1	8725-2						
85	Chain	As Req'd	HCCB005						
86	Capscrew	2	52303						
87	Nut	3	51682						
88	Bracket	1	12064-1			12064-2	12064-1	12064-2	
89	Capscrew	1	53546						
90	Washer	1	53978						
91	Chain Container	1	Refer to Chain Container Chart						

Chain Container Chart

Model Number	Chain Container Part Number and Chain Length Capacity																	
	Low Capacity												High Capacity					
	71128029		71128037		71128052		71128045		71128060		71128078		CC-8		CC-6		CC-9	
	ft.	m	ft.	m	ft.	m	ft.	m	ft.	m	ft.	m	ft.	m	ft.	m	ft.	m
VL2-005	20	6	41	12.5	53	16	77	23.5	101	30.8	167	51	214	65.2	250	76.2	428	130.5
VL2-010	13	4	26	8	34	10.4	49	15	64	19.5	105	32	111	33.8	158	48	261	79.6
VL2-015	10	3	20	6	26	8	38	11.6	50	15.2	82	25	95	29	124	37.8	202	61.6
VL2-020	—	—	16	5	21	6.4	30	9	40	12.2	66	20	78	23.8	98	29.8	165	50.3
VL2-030	—	—	10	3	13	4	19	5.8	25	7.6	41	12.5	47	14.3	62	19	101	30.8
VL2-050	—	—	—	—	—	—	12	3.7	15	4.6	25	7.6	29	8.8	38	11.6	62	19
VL2-080	—	—	—	—	—	—	—	—	10	3	17	5.2	19	5.8	25	7.6	41	12.5
VL2-100	—	—	—	—	—	—	—	—	—	—	12	3.7	14	4.3	19	5.8	31	9.4

ACCESSORIES

Chain Lubricant	LUBRI-LINK-GREEN
Overload Clutch Adjusting Socket	71112064

VL2 HOIST REVISIONS

VL2 Hoists manufactured prior to 1990 were supplied with a clip which was installed on wheel cover (38) and was held in position by nut (40). The clip is not required and is no longer offered as a replacement part. Lack of this part will not affect hoist performance.

Overload clutches were supplied as an optional feature (not standard) on older versions of the VL2 hoist. Older hoists that were equipped with an overload clutch did not use overload clutch ball (93) and spring (94). Supporter (78) and handwheel (31) are completely interchangeable, between older and newer hoists.

CHAINING INFORMATION

1/2, 1, 1-1/2 and 2 ton Hoists
Single chain fall

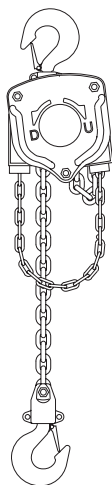

(Dwg. MHP0037)

3 and 5 ton Hoists
Two chain falls



(Dwg. MHP0038)

8 ton Hoist
Three chain falls

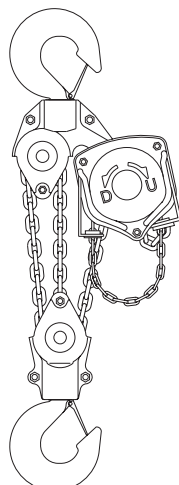

(Dwg. MHP0443)

10 ton Hoist
Four chain falls



(Dwg. MHP0444)

15 ton Hoist
Six chain falls

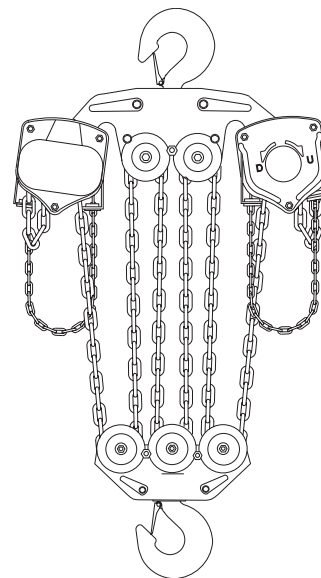

(Dwg. MHP0039)

Note:

The 20 ton hoist is similar to the 15 ton hoist but uses one extra idle sheave on the top and bottom hook frames and has eight chain falls.

PARTS ORDERING INFORMATION

Use of other than genuine **Ingersoll-Rand** replacement parts may result in decreased hoist performance and may invalidate the warranty. For prompt service and genuine **Ingersoll-Rand** parts provide your nearest Distributor with the following:

1. Complete model number as it appears on the nameplate:
VL2 plus capacity (VL2-XXX).
2. Part number and part name as shown in manual.
3. Quantity required.

The hoist nameplate is located on the gear cover. Example shown is for a 3 ton **VL2** hoist.

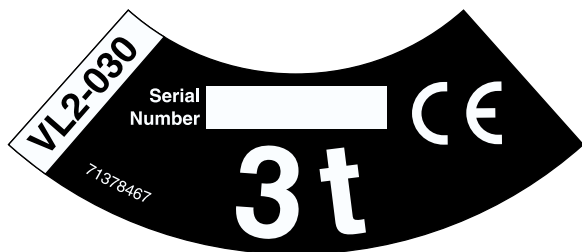

For your convenience and future reference it is recommended that the following information be recorded.

Hoist Model Number: _____

Hoist Serial Number: _____

Date Purchased: _____

Return Goods Policy

Ingersoll-Rand will not accept any returned goods for warranty or service work unless prior arrangements have been made and written authorization has been provided from the location where the goods were purchased. Hoists returned with opened, bent or twisted hooks, or without chain and hooks, will not be repaired or replaced under warranty.

NOTICE

- Continuing improvement and advancement of design may cause changes to this hoist which are not included in this manual. Manuals are periodically revised to incorporate changes. Always check manual edition number on front cover for latest issue.
- If your hoist has special finish requirements for painted parts, please specify when ordering.

Disposal

When the life of the hoist has expired, it is recommended that hoist be disassembled, degreased and parts separated as to materials so that they may be recycled.

SERVICE NOTES

WARRANTY

Ingersoll-Rand Company (I-R) warrants to the original user its Hoists and Winches (Products) to be free of defects in material and workmanship for a period of one year from the date of purchase. **I-R** will repair, without cost, any Product found to be defective, including parts and labor charges, or at its option, will replace such Products or refund the purchase price less a reasonable allowance for depreciation, in exchange for the Product. Repairs or replacements are warranted for the remainder of the original warranty period.

If any Product proves defective within its original one year warranty period, it should be returned to any Authorized Hoist and Winch Service Distributor, transportation prepaid with proof of purchase or warranty card.

This warranty does not apply to Products which **I-R** has determined to have been misused or abused, improperly maintained by the user, or where the malfunction or defect can be attributed to the use of non-genuine **I-R** parts.

I-R makes no other warranty, and all implied warranties including any warranty of merchantability or fitness for a particular purpose are limited to the duration of the expressed warranty period as set forth above. I-R's maximum liability is limited to the purchase price of the Product and in no event shall I-R be liable for any consequential, indirect, incidental, or special damages of any nature rising from the sale or use of the Product, whether based on contract, tort, or otherwise.

Note: Some states do not allow limitations on incidental or consequential damages or how long an implied warranty lasts so that the above limitations may not apply to you.

This warranty gives you specific legal rights and you may also have other rights which may vary from state to state.

IMPORTANT NOTICE

It is our policy to promote safe delivery of all orders.

This shipment has been thoroughly checked, packed and inspected before leaving our plant and receipt for it in good condition has been received from the carrier. Any loss or damage which occurs to this shipment while enroute is not due to any action or conduct of the manufacturer.

Visible Loss or Damage

If any of the goods called for on the bill of lading or express receipt are damaged or the quantity is short, do not accept them until the freight or express agent makes an appropriate notation on your freight bill or express receipt.

Concealed Loss or Damage

When a shipment has been delivered to you in apparent good condition, but upon opening the crate or container, loss or damage has taken place while in transit, notify the carrier's agent immediately.

Damage Claims

You must file claims for damage with the carrier. It is the transportation company's responsibility to reimburse you for repair or replacement of goods damaged in shipment. Claims for loss or damage in shipment must not be deducted from the

Ingersoll-Rand invoice, nor should payment of **Ingersoll-Rand** invoice be withheld awaiting adjustment of such claims as the carrier guarantees safe delivery.

You may return products damaged in shipment to us for repair, which services will be for your account and form your basis for claim against the carrier.

Authorized Sales & Service

J. HERBERT CORPORATION

Call 1-800-255-0588

407-846-0588 Fax: 846-1066

info@jherbertcorp.com

Visit us online:

www.jherbertcorp.com

