OWNER'S MANUAL SUPPLEMENT

ELECTRIC CHAIN HOIST ER and NER SERIES

**8 Ton through 20 Ton Capacity
4.7 HP MOTOR VERSION**

Code, Lot and Serial Number

⚠ WARNING

This equipment should not be installed, operated or maintained by any person who has not read and understood all the contents of this manual. Failure to read and comply with the contents of this manual can result in serious bodily injury or death, and/or property damage.

HARRINGTON
HOISTS AND CRANES

IMPORTANT INFORMATION ON HOW TO USE THIS MANUAL

This OWNER'S MANUAL SUPPLEMENT is intended for use *in combination* with the "Owner's Manual for Electric Chain Hoist ER and NER Series 1/8 through 5 Ton Capacity". Refer to the Table of Contents below to determine the location(s) of information pertaining to your hoist. References to the "Owner's Manual for Electric Chain Hoist ER and NER Series 1/8 through 5 Ton Capacity" will be designated by the use of the acronym "EROM".

Table of Contents

Section	Page Number/Location
1.0 Important Information and Warnings.....	EROM
1.1 Terms and Summary	EROM
1.2 Warning Tags and Labels	EROM
2.0 Technical Information.....	4
2.1 Specifications	4
2.2 Dimensions	5
3.0 Preoperational Procedures	6
3.1 Fill Gear Box with Oil	6
3.2 Chain	6
3.3 Mounting Location	8
3.4 Mounting the Hoist	9
3.5 Electrical Connections	9
3.6 Preoperational Checks and Trial Operation	12
4.0 Operation.....	EROM
4.1 Introduction	EROM
4.2 Shall's and Shall Not's for Operation	EROM
4.3 Hoist Controls	EROM

Section	Page Number/Location
5.0 Inspection.....	13 and EROM
5.1 General	EROM
5.2 Inspection Classification	EROM
5.3 Frequent Inspection	EROM
5.4 Periodic Inspection	EROM
5.5 Occasionally Used Hoists	EROM
5.6 Inspection Records	EROM
5.7 Inspection Methods and Criteria	13 and EROM
6.0 Maintenance & Handling.....	16 and EROM
6.1 Count/Hour Meter	EROM
6.2 Lubrication	16 and EROM
6.3 Motor Brake	16 and EROM
6.4 Load Chain	16 and EROM
6.5 Friction Clutch and Mechanical Load Brake with Friction Clutch	EROM
6.6 Storage	EROM
6.7 Outdoor Installation	EROM
7.0 Troubleshooting	EROM
8.0 Material Safety Data Sheets.....	EROM
8.1 ER Model Gear Box Oil	EROM
8.2 ER Model Load Chain Grease	EROM
9.0 Warranty.....	EROM
10.0 Parts List.....	20

2.0 Technical Information

2.1 Specifications

2.1.1 Product Code

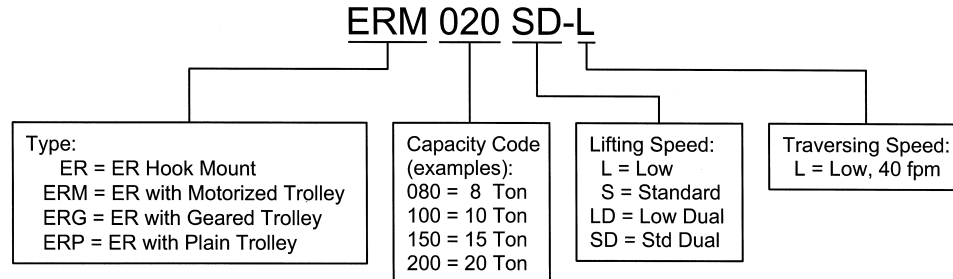

2.1.2 8 through 20 ton hoists are available in one standard specification:

- Dual Speed Motor
- Mechanical Load Brake/Friction Clutch Combination
- Count/Hour Meter
- Upper/Lower Limit Switch

2.1.3 Operating Conditions and Environment

Temperature range: -4° to +104°F (-20° to +40°C)

Relative Humidity: 85% or less

Enclosure Rating: Hoist Meets IP 55, Pendant Meets IP65

Supply Voltage: Standard 208-230/460V-3-60, Optional 575V-3-60, Special Voltages Available

Hoist Speed:	Single	Dual
ASME Duty Classification:	H4	H4
Intermittent Duty Rating:	60% ED	40%/20% ED
	360 starts/hour	120/240 starts/hour
Short Time Duty Rating:	60 min.	30/10 min.

Table 2-1 Hoist Specifications

	Capacity (Ton)	Product Code	Lifting Speed (ft/min)	Motor		Load Chain Wire Diameter (mm) x Chain Fall Lines	Load Sheave Pockets	Net Weight (lbs.)	Weight for One Addnl. FT. of Lift (lbs.)	
				Output (hp)	Current Draw (amps)					
					208V or 230V					460V
Single Speed	8	ER080S	8	4.7	18.3	9.2	4	439	5.9	
	10	ER100L	6							11.2 x 3
	10	ER100L-LG		11.2 x 4	496	8.1				
	10	ER100S	12	11.2 x 4	683					
	15	ER150S	8	11.2 x 6	897	12.1				
	20	ER200S	6	11.2 x 8	1065	16.1				
Dual Speed	8	ER080SD	8/3	4.7/1.6	19.6/9.4	9.8/4.7	4	485	5.9	
	10	ER100LD	6/2							11.2 x 3
	10	ER100LD-LG		11.2 x 4	542	8.1				
	10	ER100SD	12/4	11.2 x 4	772					
	15	ER150SD	8/3	11.2 x 6	985	12.1				
	20	ER200SD	6/2	11.2 x 8	1153	16.1				

2.2 Dimensions

Table 2-2 Hoist Dimensions

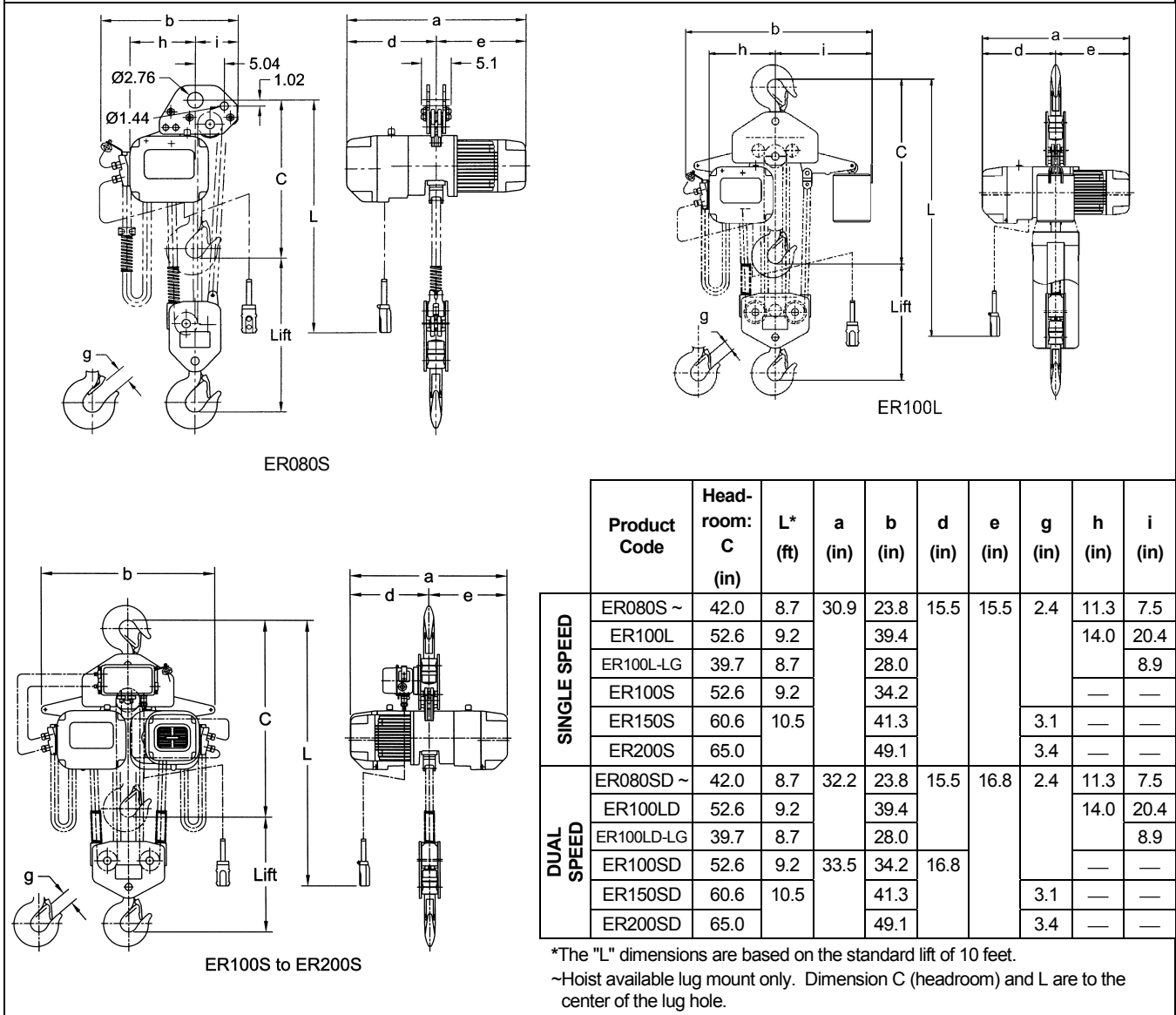

Table 2-3 Hook Dimensions*

Capacity Code	Hook	a	b	c	d	e	g
080S	B	3.3	2.2	2.9	1.9	3.3	2.4
100L, 100S	T & B	3.3	2.2	2.9	1.9	3.3	2.4
150S	T & B	4.1	2.8	3.4	2.4	3.9	3.1
200S	T & B	4.6	3.3	3.9	2.8	4.3	3.4

T = Top Hook
 B = Bottom Hook
 Units = in.

*Refer to EROM Section 5.7 for inspection dimensions and limits.

3.0 Preoperational Procedures

3.1 Fill Gear Box with Oil

- 3.1.1 **CAUTION** DO NOT use any oil or quantity other than that listed below.
- 3.1.2 For a new hoist the correct quantity and type of oil is supplied with the hoist in separate containers. Remove the fill plug from the top of the hoist and connect the flexible pour tube to the oil container. Pour in all of the oil from the separate containers, then replace the fill plug.
- 3.1.3 Refer to Section 6.2 of the **EROM** when replacing the gear oil or checking the gear oil level.

Capacity Code	Quarts	Liters
080S, 100L	3.17	3.0
100S, 150S, 200S	6.34 (3.17 per hoist body)	6.0 (3.0 per hoist body)

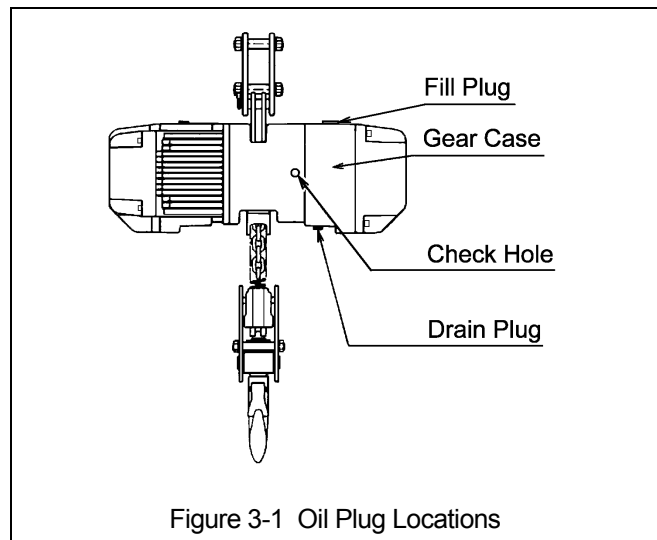

Figure 3-1 Oil Plug Locations

ER Gear Oil:

- Harrington standard: Antoil super B (NIPPON OIL)
- Acceptable equivalent: Meropa No.68 (TEXACO)

3.2 Chain

- 3.2.1 The quantity and location of the chain components including chain springs and stoppers depends on the hoist model and capacity. Never operate the hoist with incorrect, missing or damaged chain components. Refer to the hoist's nameplate, Table 3-2, and Figure 3-2 and ensure that all chain components are in the correct location and properly installed.
- 3.2.2 When the hoist is used without a chain container, the free end of the chain is attached to the hoist body as shown in Figure 3-2. Connect the "no load" end of the chain to Chain Guide A and the pre-installed socket bolt and lock nut. Make sure the chain remains free of twists and the chain Stopper is installed on the correct link. Refer to Table 3-2 for proper placement of Stopper.

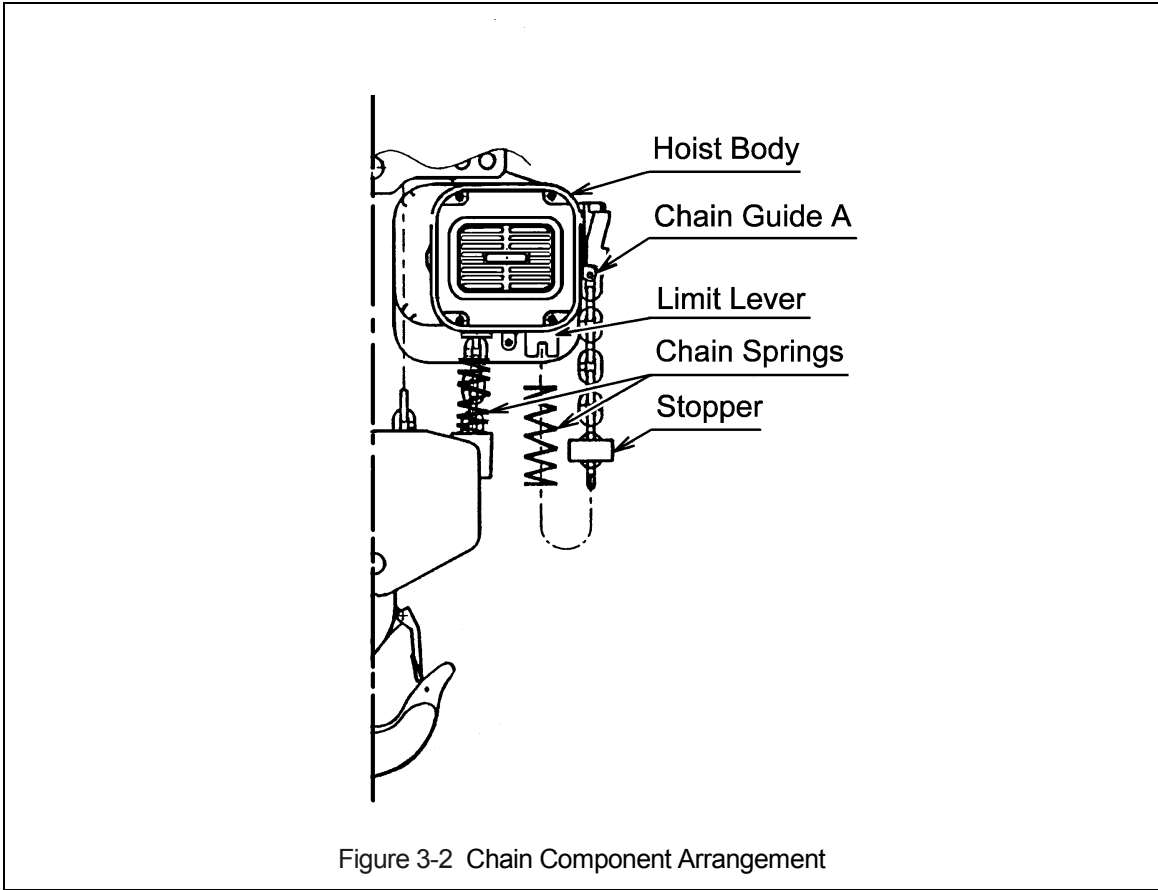

Figure 3-2 Chain Component Arrangement

Capacity Code	Without Chain Container	With Chain Container
080S, 100L, 100S, 150S, 200S	9 th link from the free end	3 rd link from the free end

3.2.3 When the optional canvas chain container(s) is used, unfold it fully and install it on the hoist body(ies) as shown in Figure 3-3. In this case the free end of the chain is not attached to the hoist body and the chain stopper is installed on the third link from the free end. To place the chain into the chain container(s), feed the chain into the chain container(s) beginning with the free end. Take care to avoid twisting or tangling the chain. NEVER put all the chain into the container(s) at once. Lumped or twisted chain may activate the down limit switch and stop the hoist during lowering.

3.2.4 **CAUTION** Each chain container indicates the maximum length of the load chain that can be stored in the container. The amount of chain the container must hold is equal to the lift on the hoist. DO NOT use a chain container with a storage capacity less than the lift length on the hoist. If all of the chain can not be stored in the container, the limit switch will not operate properly.

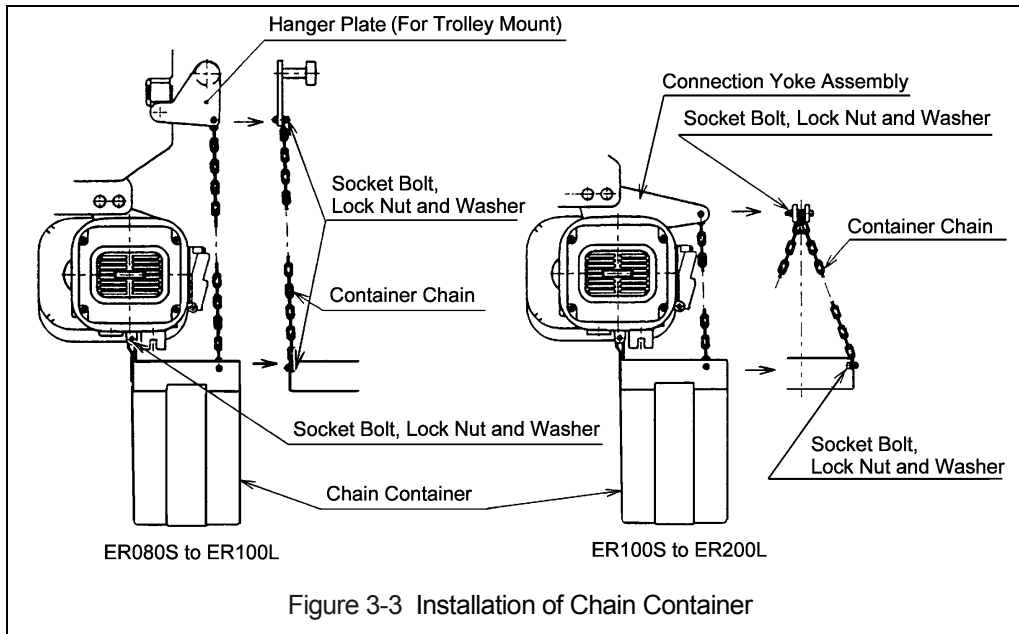

Figure 3-3 Installation of Chain Container

- 3.2.5 When using an optional steel chain container, refer to the instructions and/or assembly drawing(s) provided with the container for correct assembly and attachment.
- 3.2.6 **⚠ WARNING** Verify that the load chain is not twisted or tangled prior to operating the hoist. Make sure the bottom hook is not capsized. See Figures 3-4. Correct all chain irregularities before conducting the first hoist operation.
- 3.2.7 Lubricate the entire length of the load chain with the supplied tube(s) of grease per the instructions in Section 6.2.1.

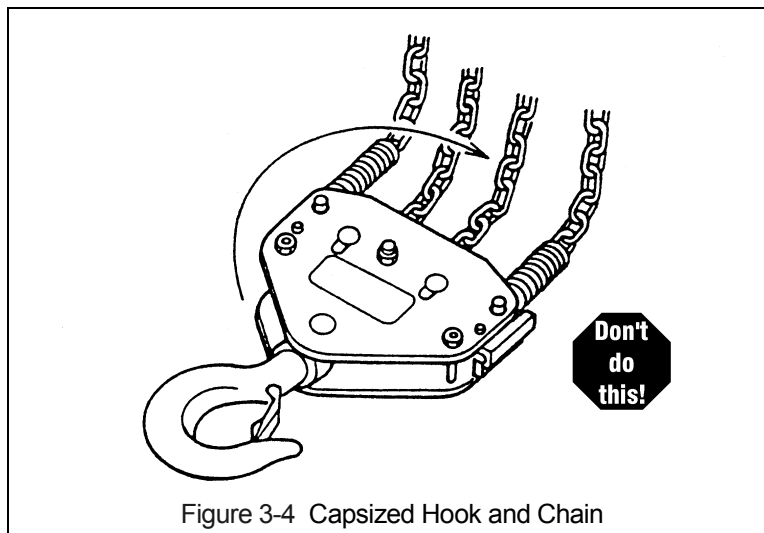

Figure 3-4 Capsized Hook and Chain

3.3 Mounting Location

- 3.3.1 **⚠ WARNING** Prior to mounting the hoist ensure that the suspension and the supporting structure are adequate to support the hoist and its loads. If necessary consult a professional that is qualified to evaluate the adequacy of the suspension location and its supporting structure.

- 3.3.2 **NOTICE** See Section 6.7 of the **EROM** for outdoor installation considerations.

3.4 Mounting the Hoist

- 3.4.1 Manual Trolley - Follow instructions in Owner's Manual provided with the trolley.
- 3.4.2 Motorized Trolley - Follow instructions in Owner's Manual provided with the trolley.
- 3.4.3 Hook Mounted to a Fixed Location - Attach the hoist's top hook to the fixed suspension point.
- 3.4.4 Lug Mounted ER080S and ER100L-LG – To maintain proper balance when the hoist is not loaded, it is necessary to install a stabilizing shaft to prevent the hoist from pivoting on the main support shaft. Refer to Table 2-2 for the size and location of the main support and stabilizing holes in the hoist's top suspension plates.
- 3.4.5 **WARNING** Ensure that the fixed suspension point rests on the center of the hook's saddle and that the hook's latch is engaged.

3.5 Electrical Connections

- 3.5.1 **CAUTION** Ensure that the voltage of the electric power supply is proper for the hoist or trolley.
- 3.5.2 **DANGER** Before proceeding, ensure that the electrical supply for the hoist or trolley has been de-energized (disconnected). Lock out and tag out in accordance with ANSI Z244.1 "Personnel Protection -Lockout/Tagout of Energy Sources".
- 3.5.3 This instruction applies to installations where the hoist is installed hook mounted to a fixed suspension point or installed on a manual trolley. In this case the hoist is controlled by a pendant with two push buttons – one for raising and one for lowering. Refer to the appropriate trolley Owner's Manual if the hoist is installed on a motorized trolley.

Pendant Cord

The Pendant Cord connects to the hoist via a 5-pin (5P) Plug and Socket. Make this connection as follows:

- Refer to Figure 3-5 or 3-6 depending on the Product Code.
- For ER080S and ER100L - Insert the 5P Plug into the 5P Socket on the hoist body and hand tighten the Screw Coupling. Install the strain relief cable to the bottom of the hoist body.
- For ER100S, ER150S and ER200S - Insert the 5P Plug into the 5P Socket on the switch box and hand tighten the Screw Coupling. Install the strain relief cable onto the cord strain relief stopper located at the 5P socket.

Power Supply Cable - Hoist Connection

The Power Supply Cable connects to the hoist via a 4-pin (4P) plug and socket or a direct fitting depending on the product code. Make this connection as follows:

- Refer to Figure 3-5 or 3-6 depending on the product code.
- For ER080S and ER100L insert the 4P plug of the Power Supply Cable into the 4P Socket on the hoist and hand tighten the screw coupling.
- For ER100S, ER150S, and ER200S – The power supply cable should be pre-installed to the switch box and properly connected.
- Install the Cable Support Arm (pre-installed on the Power Supply Cable) on to the Socket Holder or Switch Box depending on the product code. Use the pre-installed Machine Screws and Lock Washers.
- Use care to avoid twisting or kinking the Power Supply Cable.

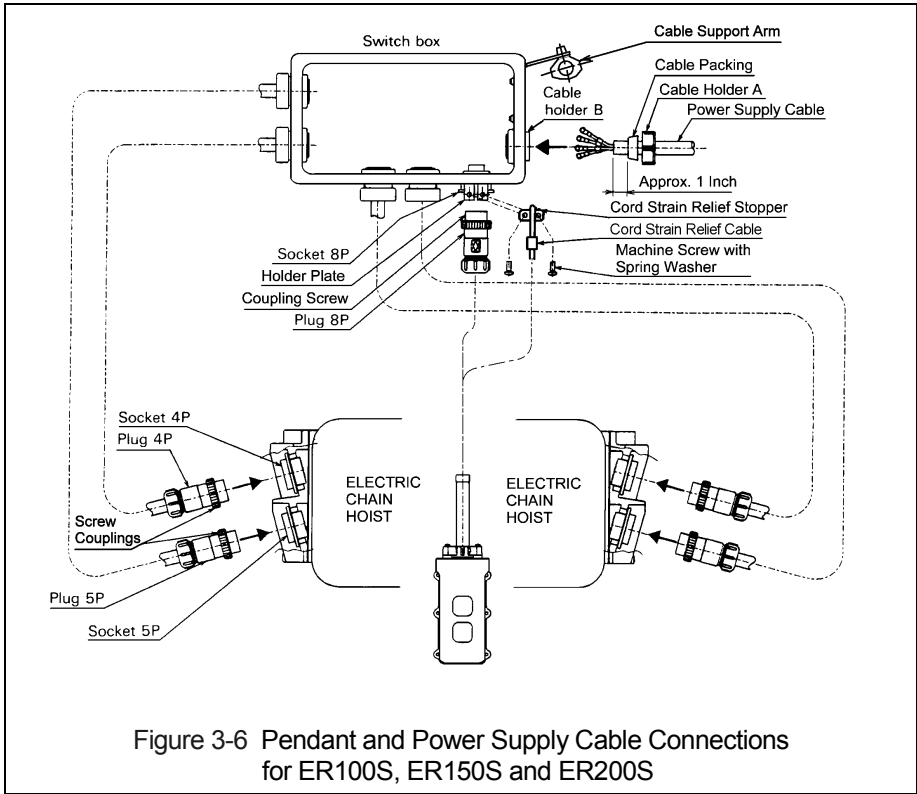
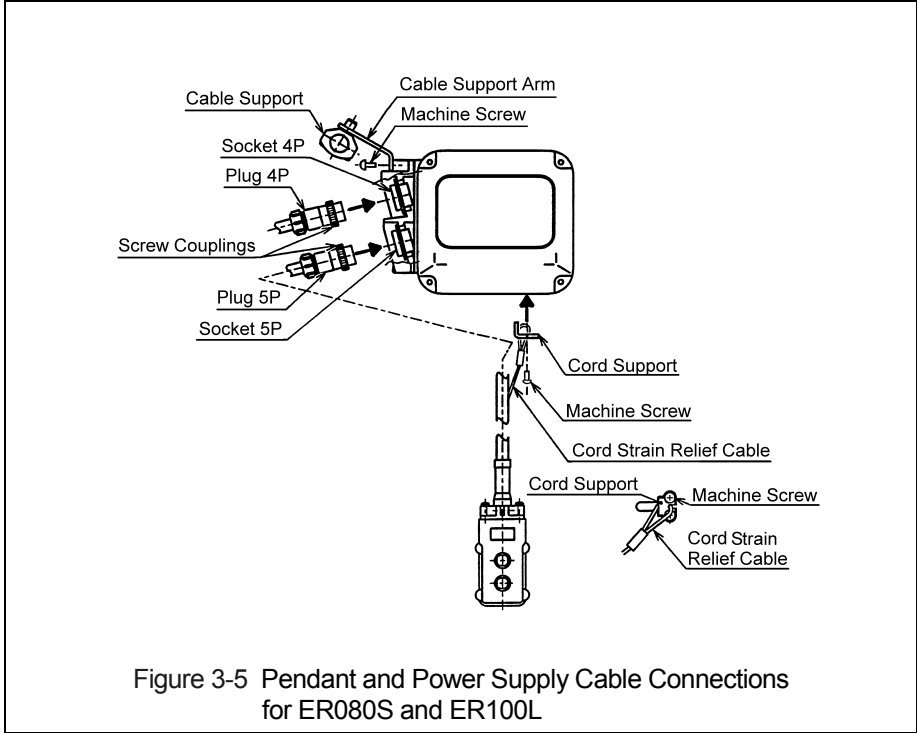

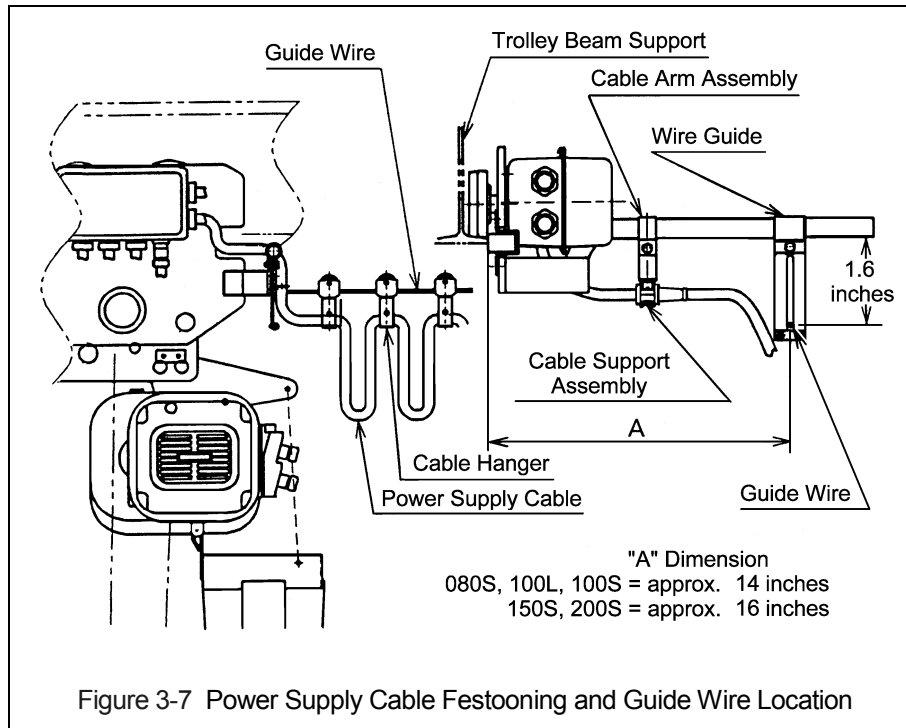

Figure 3-7 Power Supply Cable Festooning and Guide Wire Location

Power Supply Cable - Installation

If the hoist is hook mounted to a fixed support ensure that the Power Supply Cable is properly installed and supported between the hoist and the electrical power supply.

If the hoist is installed on a manual trolley, then the Power Supply Cable must be installed along the beam that the trolley runs on. For curved beams a special cable suspension system will be needed, and this instruction does not apply. For straight beams install the Power Supply Cable as follows:

- Refer to Figure 3-7.
- Install the Cable Hangers on to the Power Supply Cable spacing them every 5 feet.
- Install a Guide Wire system parallel to the Bridge Beam. Pass the Guide Wire through the Cable Hangers and the Wire Guide.
- Make sure the Guide Wire is properly tensioned and the Power Supply Cable is not twisted or kinked.

3.5.4 Connection to Electrical Power Source - The red, white, and black wires of the Power Supply Cable should be connected to an Electric Power Disconnect Switch or Circuit Breaker. This connection should be made so that the hoist is phased properly. Refer to Section 3.6.11 for instructions on how to check for correct power supply phase connection.

3.5.5 Fuse/Breaker Capacity -The hoist's power supply should be equipped with overcurrent protection such as fuses, which should be selected for 110% to 120% of total listed full load amperage, and should be dual element time-delay fuses. Refer to the motor nameplate(s) for the full load amperage draw.

3.5.6 **⚠ DANGER** Grounding - An improper or insufficient ground connection creates an electrical shock hazard when touching any part of the hoist or trolley. In the Power Supply Cable the ground wire will be either Green with Yellow stripe or solid Green. It should always be connected to a suitable ground connection. Do not paint the trolley wheel running surfaces of the beam as this can affect grounding.

3.6 Preoperational Checks and Trial Operation

- 3.6.1 Refer to the hoist's nameplate and record the hoist's Code, Lot and Serial Number in the space provided on the cover of this manual.
- 3.6.2 **⚠ WARNING** Confirm the adequacy of the rated capacity for all slings, chains, wire ropes and all other lifting attachments before use. Inspect all load suspension members for damage prior to use and replace or repair all damaged parts.
- 3.6.3 **⚠ WARNING** Verify and correct all chain irregularities prior to operating the hoist. Refer to Section 3.2 of this manual.
- 3.6.4 Measure and record the “k” dimension of all hooks on hoist. See Table 5-4 under Section 5 “Inspection”, of this manual.
- 3.6.5 Ensure that the hoist is properly installed to either a fixed point, or trolley, whichever applies.
- 3.6.6 If hoist is installed on a trolley, ensure that
- trolley is properly installed on the beam, and
 - stops for the trolley are correctly positioned and securely installed on the beam.
- 3.6.7 Ensure that all nuts, bolts and split pins (cotter pins) are sufficiently fastened.
- 3.6.8 Pull down on the Pendant and ensure that the Cord Strain Relief Cable takes the force, not the Pendant Cord.
- 3.6.9 **⚠ CAUTION** Check supply voltage before everyday use. If the voltage varies more than 10% of the rated value, electrical devices may not function normally.
- 3.6.10 Confirm proper operation.
- Before operating read and become familiar with Section 4 – Operation in the **EROM**.
 - Before operating ensure that the hoist (and trolley) meets the Inspection, Testing and Maintenance requirements of ANSI/ASME B30.16.
 - Before operating ensure that nothing will interfere with the full range of the hoist's (and trolley's) operation.
- 3.6.11 Proceed with trial operation to confirm proper operation.
- Verify that the controls agree with hoist direction. Make sure that depression of the up button lifts the load chain and depression of the down button lowers the load chain hook. If the load chain does not move in the correct direction when the push buttons are pushed, the power supply is phased incorrectly. In this case, turn off the power source or breaker switch then reverse any two of the three wires at the power source. The hook will then move in accordance with the directions of the push button.
 - Perform inspections per Section 5.2, “Frequent Inspections” in the **EROM**.

5.0 Inspection

NOTICE

The information listed in this section is intended to supplement Section 5.7 of the EROM.

Table 5-3 Hoist Inspection Methods and Criteria			
Use this table in conjunction with Table 5-3 of the EROM. The entries in this table replace in their entirety the corresponding entries in Table 5-3 of the EROM.			
Item	Method	Criteria	Action
Hooks - Fretting wear	Measure	The "u" and "t" dimensions should not be less than discard value listed in Table 5-4	Replace.
Hooks - Stretch	Measure	The "k" dimension should not be greater than 1.15 times that measured and recorded at the time of purchase (See Section 3.6). If recorded "k" values are not available for hooks when new, use nominal "k" values from Table 5-4 .	Replace.
Load Chain - Pitch and Wire Diameter	Measure	The "P" dimension should not be greater than maximum value listed in Table 5-5 . The "d" dimension should not be less than minimum value listed in Table 5-5 .	Replace. Inspect Load and Idle Sheaves.
Load Chain – Reeving and Evening	Visual	Chain should be reeved properly through Load and Idle Sheaves - refer to Section 6.4 . Chain, Chain Springs, Stoppers, and Chain Pin should be installed properly - refer to Section 3.2 . For double body hoists, chain should be evenly distributed – equal length of chain in each chain container or equal lengths of chain on no-load side of each hoist body.	Reeve/Install chain properly. Lower hook until lower limit switch is activated on both hoist bodies.

Table 5-3 Hoist Inspection Methods and Criteria

Use this table in conjunction with Table 5-3 of the EROM. The entries in this table replace in their entirety the corresponding entries in Table 5-3 of the EROM.

Item	Method	Criteria	Action
Motor Brake	Measure, Visual	Motor brake gap should be adjusted to the distance shown in Table 6-3 before measuring the brake wear. Brake lining dimension "A" should not be less than discard value listed in Table 5-6 . Refer to Section 6.3 of the EROM for gaining access to motor brake and for adjustment and inspection procedures. Braking surfaces should be clean, free of grease/oil and should not be glazed.	Adjust, Repair or Replace as required.

Table 5-4 Top Hook & Bottom Hook Dimensions

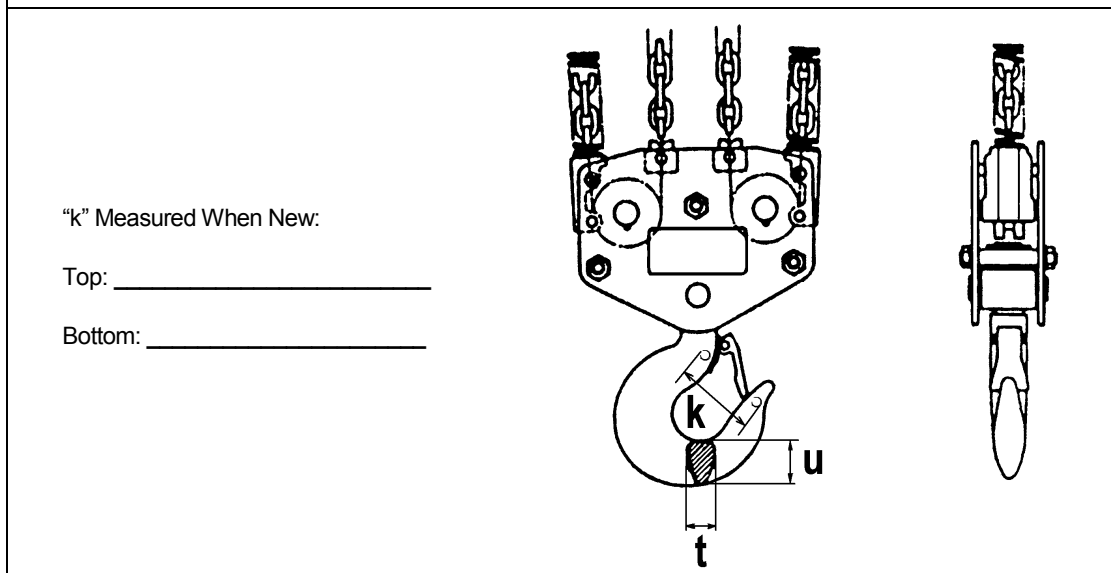

Capacity Code	Nominal "k" Dimension* inch (mm)	"u" Dimension inch (mm)		"t" Dimension inch (mm)	
		Standard	Discard	Standard	Discard
080S, 100L, 100S	4.72(120)	2.87(73)	2.60(66)	1.89(48)	1.69(43)
150S	5.04(128)	3.43(87)	3.07(78)	2.36(60)	2.13(54)
200S	5.57(141.5)	3.92(99.5)	3.54(90)	2.76(70)	2.48(63)

* These values are nominal since the dimension is not controlled to a tolerance. The "k" dimension should be measured when the hook is new - this becomes a reference measurement. Subsequent measurements are compared to this reference to make determinations about hook deformation/stretch. See Section 5.7 of EROM, "Hooks - Stretch".

Table 5-5 Chain Wear Dimensions				
Capacity Code	"P" Dimension inch (mm)		"d" Dimension inch (mm)	
	Standard	Discard	Standard	Discard
080S, 100L, 100S, 150S, 200S	6.75 (171.5)	6.85 (174.1)	0.44 (11.2)	0.40 (10.1)

Table 5-6 Motor Brake Wear Dimensions				
<p>NOTICE Brake must be properly adjusted before measuring "A". See Section 6.3 of EROM</p>				
Capacity Code	"A" Dimension - inch (mm)			
	Single Speed		Dual Speed	
	Standard	Discard	Standard	Discard
080S, 100L, 100S, 150S, 200S	0.83 (21)	0.77 (19.5)	1.54 (39)	1.48 (37.5)

6.0 Maintenance and Handling

6.2 Lubrication

6.2.1 Load Chain

- Refer to 6.2.1 of the EROM.

6.2.2 Hooks and Suspension Components:

- Refer to 6.2.2 of the EROM.

6.2.3 Gear Box:

- Refer to 6.2.3 of the EROM except use the following table for checking oil level.

Table 6-3 Criteria for Checking Hoist Gear Oil Level		
Capacity Code	Oil Level (Hoist at level position)	
	Min	Max
080S, 100L, 100S, 0150S, 200S	1" below bottom edge of check hole	Even with bottom edge of check hole.

6.3 Motor Brake - Use the table below in conjunction with Section 6.3 of the EROM. This table replaces Table 6-3 of the EROM.

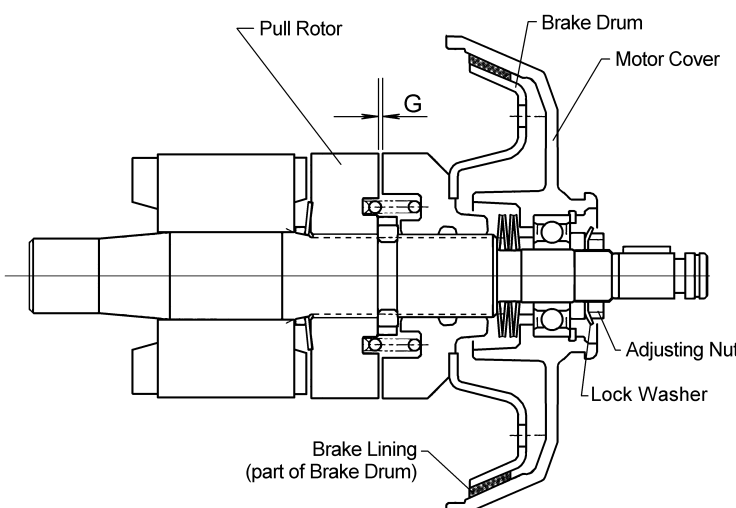
Table 6-3 Motor Brake Gap	
	
Capacity Code	Brake Gap (G) inch (mm)
080S, 100L, 100S, 150S, 200S	0.032 (0.8)

6.4 Load Chain

6.4.1 Lubrication and Cleaning – refer to Section 6.2 of EROM.

6.4.2 Load Chain Replacement for ER080S and ER100L:

- 1) **⚠ CAUTION** The hoist must be properly powered and operational in order to perform the following procedures.
- 2) **⚠ WARNING** Be certain that the replacement chain is obtained from Harrington and is the exact size, grade and construction as the original chain. The new load chain must have an odd number of links so that both its end links have the same orientation. If the load chain is being replaced due to damage or wear out, destroy the old chain to prevent its reuse.
- 3) **⚠ CAUTION** When replacing load chain, check for wear on mating parts, i.e. Load Sheave, Chain Guides and Idle Sheaves, and replace parts if necessary.
- 4) For hoists without a chain container, remove the socket bolt, lock nut, and attach the no-load side of the chain to Chain Guide A.
- 5) Remove the Stopper and Chain Spring from the no-load side of the chain for reuse on the new chain. Inspect and replace any damaged or worn parts.
- 6) Using an open link, attach the new chain to the end link of the old chain on the no-load side. The end link of the new load chain should be connected so that the welded portions of the load chain's standing links are oriented to the outside as they pass over the Load Sheave. Refer to Figure 6-3.
- 7) Operate the hoist down to move the new chain through the hoist body. Stop when a sufficient amount of new chain is accumulated on the load side.
- 8) Complete reeving as follows:
 - For ER080S pull down on Part ② until new chain is fed through the upper and lower idle sheaves. Secure the new chain at Part ② directly below the upper suspension plates to prevent the new chain from running back through the idle sheaves. Remove the open link attaching the new chain to the old chain.
 - For ER100L pull up on Part ② until the new chain is fed through the upper and lower idle sheaves. Secure the new chain at Part ② directly above the lower idle sheave to prevent the new chain from running back through the idle sheaves. Remove the open link attaching the new chain to the old chain.
- 9) Remove the Snap Ring and Chain Pin that attach the old chain to the chain holder for use on the new chain. Inspect and replace any damaged or worn parts.
- 10) Connect the end link of the new chain to the chain holder with the Chain Pin and Snap Ring. Ensure that the chain remains free of twists. Attach the remaining chain components to the chain referring to Section 3.2 for the proper locations. For hoists without a chain container, attach the no-load side of the chain to Chain Guide A with the socket bolt, and lock nut. See Figure 3-2.
- 11) **⚠ WARNING** Make sure the Stopper and Chain Springs are properly installed. Refer to Section 3.2.
- 12) After installation has been completed, perform steps outlined in Section 3.6 "Preoperational Checks and Trial Operation".

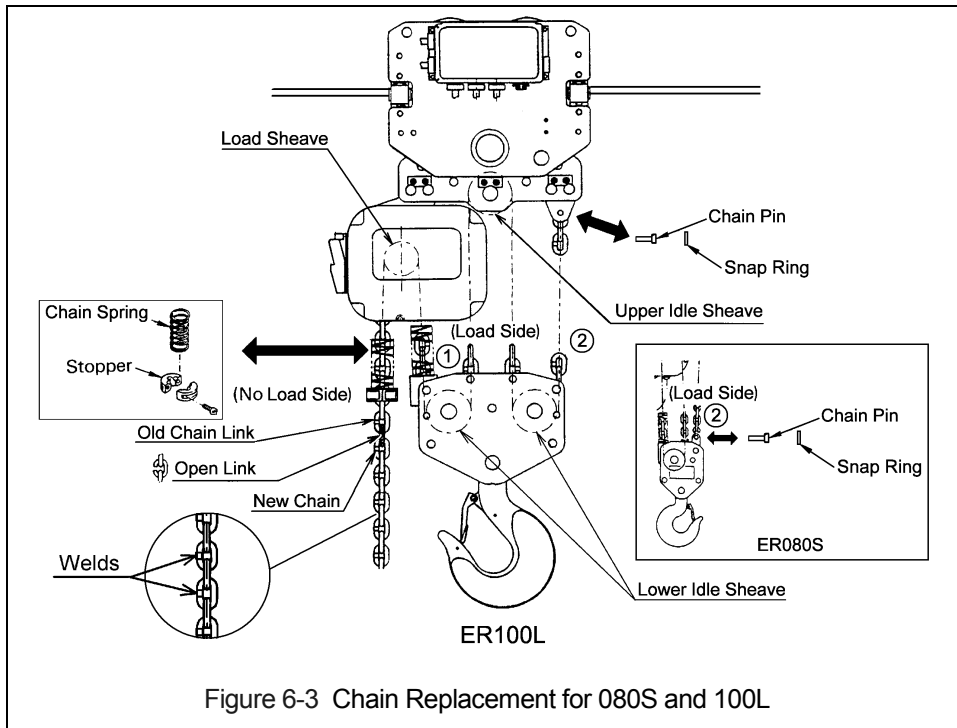
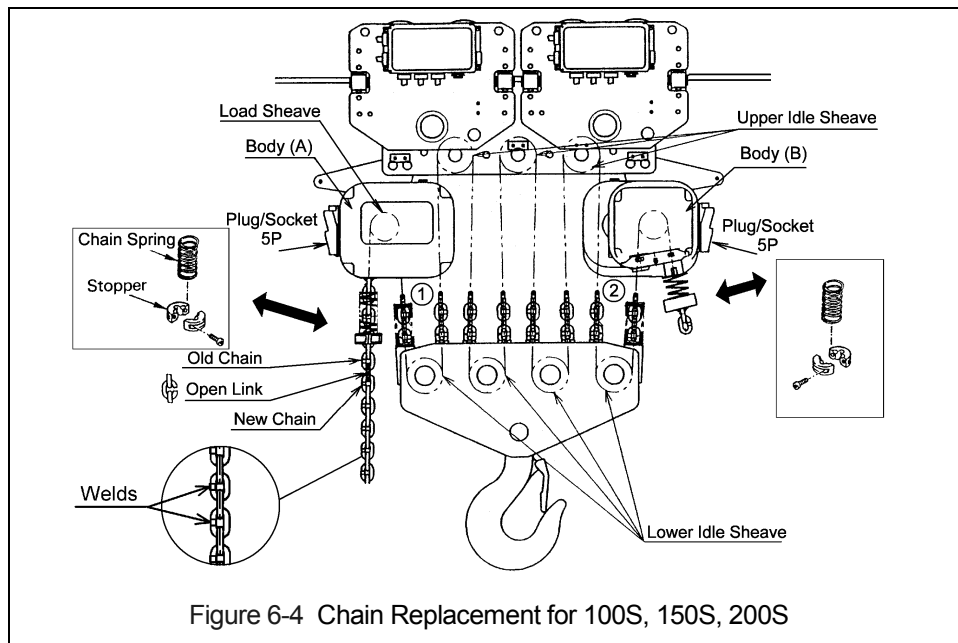

Figure 6-3 Chain Replacement for 080S and 100L

6.4.3 Load Chain Replacement for ER100S, ER150S and ER200S:

- 1) **⚠ CAUTION** The hoist must be properly powered and operational in order to perform the following procedures.
- 2) **⚠ WARNING** Be certain that the replacement chain is obtained from Harrington and is the exact size, grade and construction as the original chain. The new load chain must have an odd number of links so that both its end links have the same orientation. If the load chain is being replaced due to damage or wear out, destroy the old chain to prevent its reuse.
- 3) **⚠ CAUTION** When replacing load chain, check for wear on mating parts, i.e. Load Sheave, Chain Guides and Idle Sheaves, and replace parts if necessary.
- 4) For hoists without chain containers, remove the socket bolts, lock nuts, and attach the end links of the chain to Chain Guide A on both hoist bodies.
- 5) Remove the Stopper and Chain Spring from one end of the old chain. Inspect and replace any damaged or worn parts.
- 6) Using an open link, attach the new chain to the end link of the old chain where the Stopper and Chain Spring were removed. The end link of the new load chain should be connected so that the welded portions of the load chain's standing links are oriented to the outside as they pass over the Load Sheave. Refer to Figure 6-4.
- 7) Install the Stopper and Chain Spring to the free end of the new chain. Refer to Section 3.2 in this supplement for the correct location.
- 8) Disable Hoist Body B by unplugging its 5P plug. Operate Hoist Body A in the down direction to move the new chain through the hoist until a sufficient quantity of chain has accumulated between the hoist bodies. Re-enable Hoist Body B by re-inserting its 5P plug.
- 9) Disable Hoist Body A by unplugging its 5P plug. Operate Hoist Body B in the up direction to move the new chain through the hoist until a sufficient quantity of new chain has passed through Hoist Body B. Re-enable Hoist Body A by re-inserting its 5P plug.
- 10) Remove the open link attaching the new chain to the old chain.

- 11) Remove the remaining Stopper and Chain Spring from the old chain. Inspect and replace any damaged or worn parts. Install the Stopper and Chain Spring to the end of the new chain. Refer to Section 3.2 in this supplement for correct location.
- 12) For hoists without a chain container, attach the ends of the chain to Chain Guide A on each body with the socket bolt, and lock nut (see Figure 3-2). Ensure that all chain parts remain free of twists and correct any if found.
- 13) Even out the chain by operating the hoist down until the down Limit Switch on both hoist bodies is activated.
- 14) **⚠ WARNING** Make sure the Stopper and Chain Springs are properly installed. Refer to Section 3.2 in this supplement.
- 15) After installation has been completed, perform steps outlined in Section 3.6 "Preoperational Checks and Trial Operation".



10.0 8 to 20 Ton Parts List

When ordering Parts, please provide the Hoist code number, lot number and serial number located on the Hoist nameplate (see fig. below).

Reminder: Per sections 1.1 and 3.5.1 to aid in ordering Parts and Product Support, record the Hoist code number, lot number and serial number in the space provided on the cover of this manual.

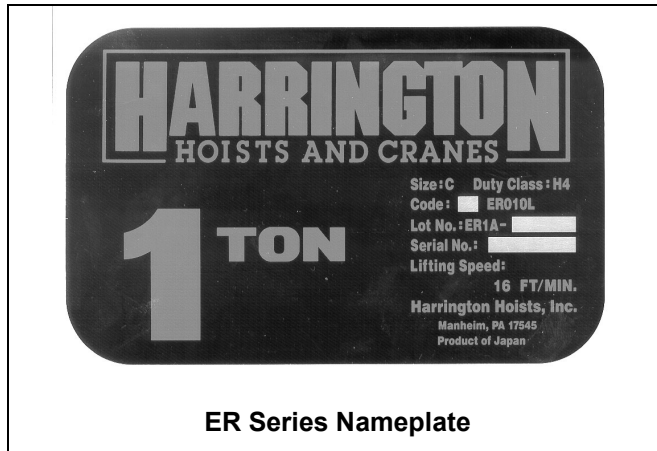

The parts list is arranged into the following sections:

Section

Parts Common to Plate Suspension (lug mount) and Hook Mount.	Page
10.1 Housing and Motor Parts.....	22
10.2 Gearing Parts.....	26
10.3 Chaining Parts.....	28
10.4 Bottom Hook Parts 8 & 10 Ton.....	30
10.5 Bottom Hook Parts 15 & 20 Ton.....	32
10.6 Electric Parts.....	34
10.7 Push Button Control Station Parts.....	36
10.8 Chain Container Parts 8 & 10(L) Ton.....	38
10.9 Chain Container Parts 10(S) thru 20 Ton.....	39
Parts for Plate Type Suspension Type.	
10.10 Push Button Type Control Station and Cable Parts.....	40
10.11 Top Suspension Plate Parts 8 & 10 Ton.....	44
10.12 Top Suspension Plate Parts 15 & 20 Ton.....	46
Parts for Hook Mount.	
10.13 Hook Type Control Station and Cable Parts.....	48
10.14 Top Hook Parts.....	50

In the column "Parts Per Trolley" a designator is used for parts that apply only to a particular model or option.

Refer to Section 2.1 for ER Hoist model numbers and additional descriptions.

The designators are:

S = Single Speed

D = Dual Speed

This Page Intentionally Left Blank

10.1 Housing and Motor Parts

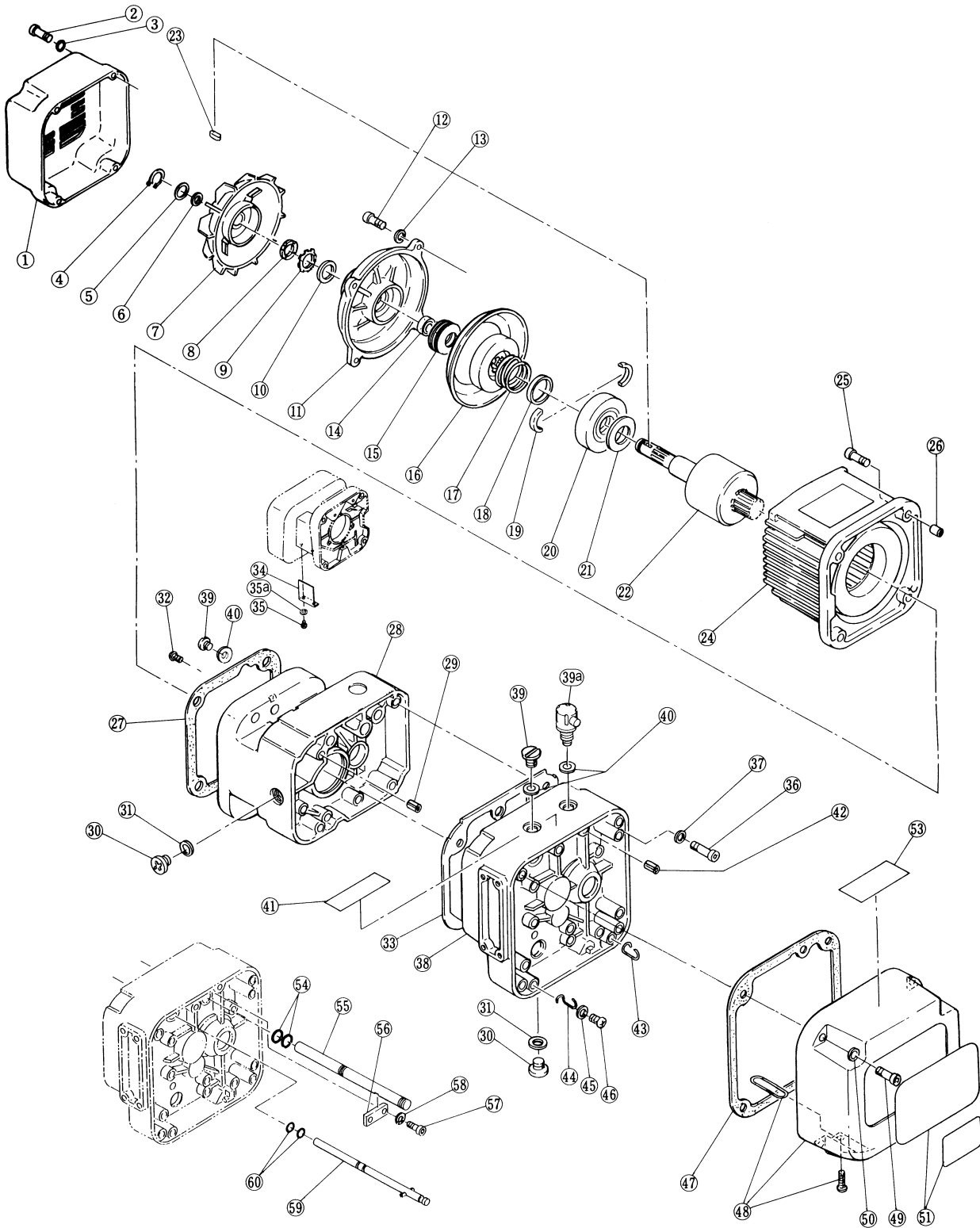

Figure 10-1 Housing and Motor Parts

10.1 Housing and Motor Parts

Figure No.	Part Name	Single Body Hoist			Double Body Hoist				
		Parts Per Hoist		080S	100L	Parts Per Hoist	100S	150S	200S
1	Fan Cover	S	1	ER1ES9107			2	ER1ES9107	
		D	1	ER1EB9107				ER1EB9107	
2	Socket Bolt		4	9091279			8	9091279	
3	Toothed Lock Washer		4	9679711			8	9679711	
4	Snap Ring		1	9047124			2	9047124	
5	Fan Washer		1	ER1ES9322			2	ER1ES9322	
6	O-Ring		1	9013318			2	9013318	
7	Fan		1	ER1ES9108			2	ER1ES9108	
8	Nut		1	ES217015			2	ES217015	
9	Lock Washer		1	ES218015			2	ES218015	
10	Spacer		1	ES216S015			2	ES216S015	
11	Motor Cover Assembly	S	1	ER1ES2106		S	2	ER1ES2106	
		D	1	ER1EB2106		D	2	ER1EB2106	
12	Socket Bolt		4	90912115			8	90912115	
13	Spring Lock Washer		4	9012713			8	9012713	
14	Collar M		1	ES192015			2	ES192015	
15	Coned Disk Spring M		4	ES191015			8	ES191015	
16	Brake Drum Assembly	S	1	ER1ES5212		S	2	ER1ES5212	
		D	1	ER1EB5212		D	2	ER1EB5212	
17	Brake Spring	S	1	ES214015		S	2	ES214015	
		D	1	ES214D015		D	2	ES214D015	
18	Collar		1	ES506015			2	ES506015	
19	Thrust Disc		2	ES505015			4	ES505015	
20	Pull Rotor		1	ES503015			2	ES503015	
21	Coned Disk Spring		1	ES504015			2	ES504015	
22	Motor Shaft with Rotor	S	1	ER1ES5502		S	2	ER1ES5502	
		D	1	ER1EB5502		D	2	ER1EB5502	
23	Key		1	ER1DS9320			2	ER1DS9320	
24	Motor Frame with Stator 208-230/460V-3-60	S	1	A1KHM20S5A		S	2	A1KHM20S5A	
		D	1	A1KHM20B5A		D	2	A1KHM20B5A	
	Motor Frame with Stator 575V-3-60	S	1	A1KHA20S5A		S	2	A1KHA20S5A	
		D	1	A1KHA20B5A		D	2	A1KHA20B5A	
25	Socket Bolt		4	90912137			8	90912137	
26	Set Pin S		2	ER1ES9138			4	ER1ES9138	
27	Packing M		1	ER1ES9118			2	ER1ES9118	
28	Body C		1	ER1ES9099			2	ER1ES9099	
29	Set Pin S		2	ES120010S			4	ES120010S	
30	Oil Plug		2	E3S111003			4	E3S111003	
31	Plug Packing		2	E3S112003			4	E3S112003	
32	Pan Head Machine Screw		1	9798543			2	9798543	
33	Packing G		1	ER1ES9116			2	ER1ES9116	
34	Body Protector		1	ER1FR9055			2	ER1FR9055	
35	Socket Bolt		2	9091272			4	9091272	
36	Socket Bolt		5	90912135			10	90912135	
37	Toothed Lock Washer		5	9679711			10	9679711	
38	Gear Case M		1	ER1ES9102			2	ER1ES9102	
39	Oil Plug B		1	ER1BS9135			2	ER1BS9135	
39a	Oil Cap Assembly		1	ER1BS1175			2	ER1BS1175	
40	Eyebolt Packing		3	ES127005S			6	ES127005S	

10.1 Housing and Motor Parts

Figure No.	Part Name	Single Body Hoist			Double Body Hoist					
		Parts Per Hoist		080S	100L	Parts Per Hoist	100S	150S	200S	
41	Name Plate OM		1	ER1BS9891			2	ER1BS9891		
42	Spring Pin		1	E3S129005S			2	E3S129005S		
43	Cover Suspender A		1	ER1BS9431			2	ER1BS9431		
44	Cover Suspender B		1	ER1BS9432			2	ER1BS9432		
45	Washer		2	ER1BS9436			4	ER1BS9436		
46	Machine Screw w/ Spring Washer		2	ES650005S			4	ES650005S		
47	Packing C		1	ER1ES9117			2	ER1ES9117		
48	Controller Cover Assembly		1	ER1ES1104			2	ER1ES1104		
49	Socket Bolt		4	9091276			8	9091276		
50	Toothed Lock Washer		4	9679711			8	9679711		
51	Name Plate B	S	1	80084	A1GHM1Q Q9A3	S	2	A1GHM1QI 9A3	A1GHM1PI 9A3	A1GHM2QI 9A3
		D	1	80085		D	2			
	Name Plate B (Blank)	D	1		A1CHM20 S9A5	D	2	A1CHM20S9A5		
	Name Plate D	D	1		A1GHM1Q S9A6	D	2	A1GHM1Q S9A6	A1GHM1P S9A6	A1GHM2Q S9A6
53	Warning Label EE		1	E2D866125			2	E2D866125		
54	O Ring		2	9013317			4	9013317		
55	Connection Shaft		1	ER1ES9121			2	ER1ES9121		
56	Plate A		1	ER1ES9123			2	ER1ES9123		
57	Socket Bolt		2	9091249			4	9091249		
58	Toothed Lock Washer		2	9012709			4	9012709		
59	Fixing Shaft Assembly		1	ER1ES1122			2	ER1ES1122		
60	O Ring		2	9013307			4	9013307		

This Page Intentionally Left Blank

10.2 Gearing Parts

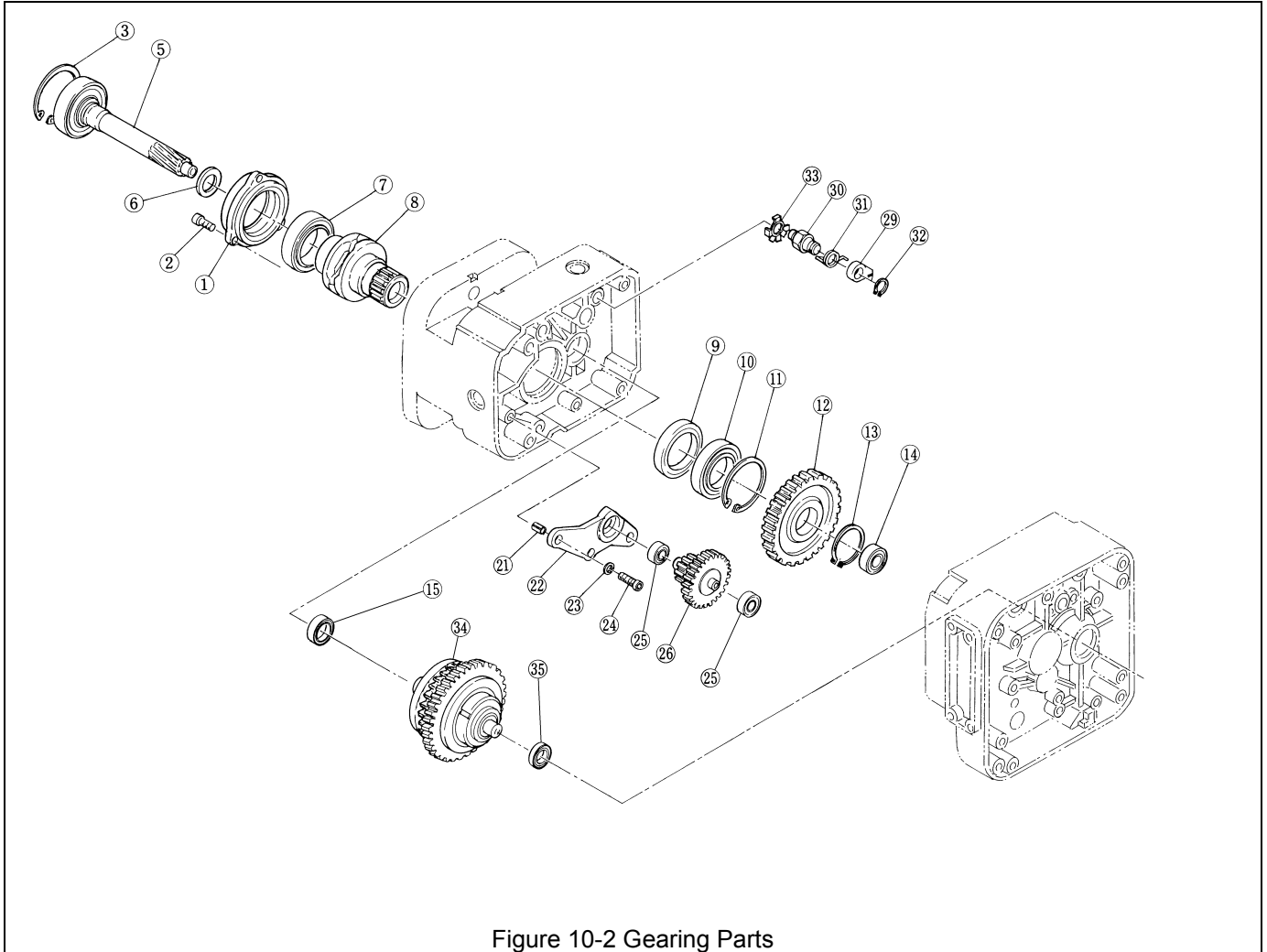

Figure 10-2 Gearing Parts

10.2 Gearing Parts

Figure No.	Part Name	Single Body Hoist			Double Body Hoist		
		Parts Per Hoist	080S	100L	Parts Per Hoist	100S	150S
1	Bearing Holder		2	ER1ES9110		2	ER1ES9110
2	Socket Bolt		3	9091249		6	9091249
3	Snap Ring		1	9047280		2	9047280
5	Pinion Assembly		1	ER1ES5220		2	ER1ES5220
6	Oil Seal		1	ES221015		2	ES221015
7	Ball Bearing		1	9000611		2	9000611
8	Load Sheave		1	ER1EM9241		2	ER1EM9241
9	Oil Seal		1	ES232015		2	ES232015
10	Ball Bearing		1	9000110		2	9000110
11	Snap Ring		1	9047280		2	9047280
12	Load Gear	S	1	ER1EM9240	S	2	ER1EM9240
		D	1	ER1EL9240	D	2	ER1EL9240
13	Snap Ring		1	9047150		2	9047150
14	Ball Bearing		1	9000304		2	9000304
15	Ball Bearing		1	9000405		2	9000405
21	Set Pin	S	0		S	0	
		D	2	ES120010S	D	4	ES120010S
22	Gear Plate	S	0		S	0	
		D	1	ER1FS9261	D	2	ER1FS9261
23	Spring Lock Washer	S	0		S	0	
		D	3	9012711	D	6	9012711
24	Socket Bolt	S	0		S	0	
		D	3	9091275	D	6	9091275
25	Ball Bearing	S	0		S	0	
		D	2	9000302	D	4	9000302
26	Gear B Assembly	S	0		S	0	
		D	1	ER1EL5262	D	2	ER1EL5262
29	Pawl		1	ES268010S		2	ES268010S
30	Pawl Shaft		1	ER1ES9286		2	ER1ES9286
31	Pawl Spring		1	ER1ES9290		2	ER1ES9290
32	Snap Ring		1	9047116		2	9047116
33	Pawl Shaft Washer		1	ER1ES9294		2	ER1ES9294
34	Mechanical Brake with Friction Clutch Set	S	1	ER1EM1274		2	ER1EM1274
		D	1	ER1EP1274		2	ER1EP1274
35	Ball Bearing		1	9000304		2	9000304

10.3 Chaining Parts

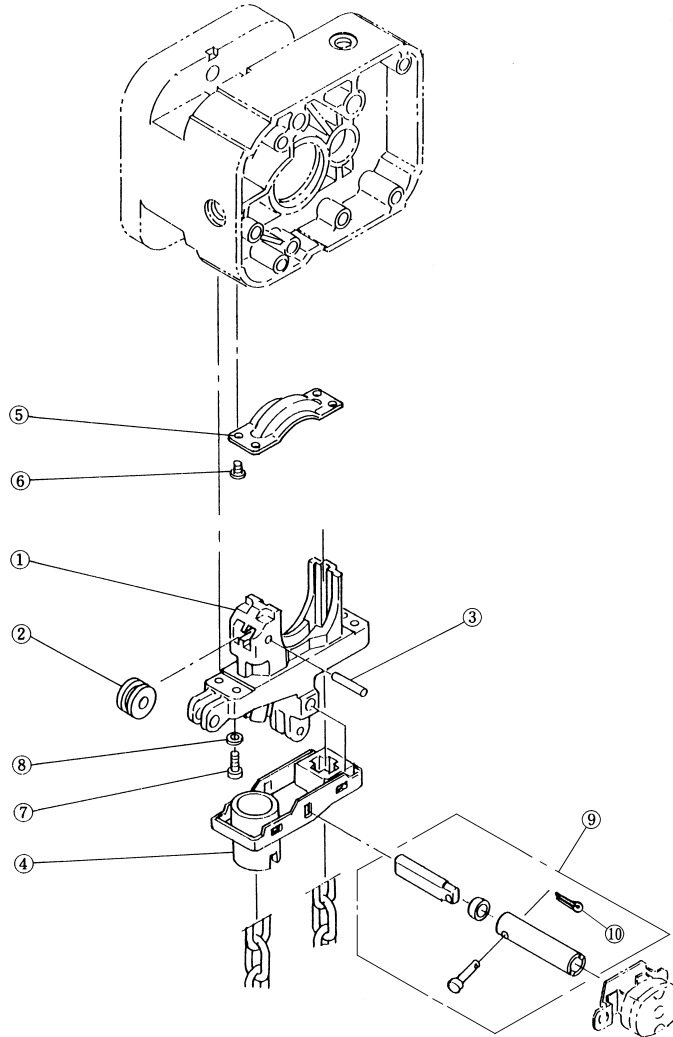

Figure 10-3 Chaining Parts

Figure No.	Part Name	Single Body Hoist		Double Body Hoist			
		Parts Per Hoist	080S	100L	Parts Per Hoist	100S	150S
1	Chain Guide AL	1	ER1EM9330		2	ER1EM9330	
2	Guide Roller	1	ER1EM9333		2	ER1EM9333	
3	Roller Pin	1	ER1ES9334		2	ER1ES9334	
4	Limit Lever Assembly	1	ER1EM5335		2	ER1EM5335	
5	Chain Guide B	1	ER1EM9332		2	ER1EM9332	
6	Machine Screw with Spring Washer	4	E6F151003		8	E6F151003	
7	Socket Bolt	4	9091274		8	9091274	
8	Spring Lock Washer	4	9012711		8	9012711	
9	Lever Pin Coupling Assembly	1	ER1ES1338		2	ER1ES1338	
10	Split Pin	1	9009410		2	9009410	

This Page Intentionally Left Blank

10.4 Bottom Hook Parts 8 & 10 TON

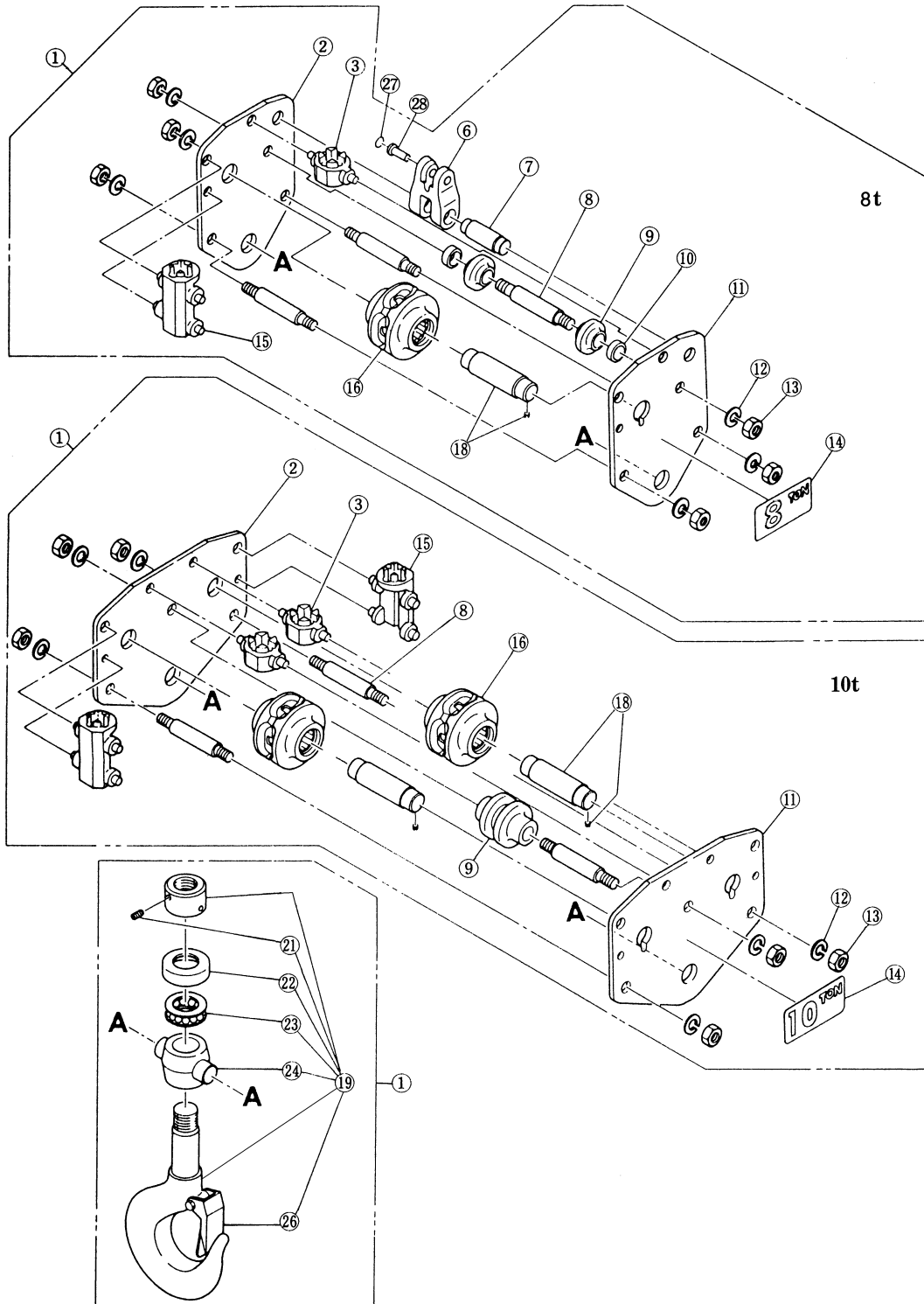

Figure 10-4 Bottom Hook Parts

10.4 Bottom Hook Parts 8 & 10 Ton

Figure No.	Part Name	Parts Per Hoist	080S	100L & 100S
1	Bottom Hook Complete Set	1	ER1HS1121	ER1IS1121
2	Bottom Suspension Plate B	1	E6S035075	E6S035100
3	Bottom Cross Guide	(X)	E6S067075 (1)	E6S067075 (2)
4	Snap Ring	1	9047121	
6	Chain Holder	1	E6S039075	
7	Chain Holder Pin	1	E6S040075	
8	Bottom Stay Bolt	3	E6S038075	
9	Guide Roller	2	E6S062075	
		1		E6S063100
10	Bottom Collar	2	E6S065075	
11	Bottom Suspension Plate A	1	E6S034075	E6S034100
12	Spring Washer	6	E6S082075	
13	Nut	6	E6S081075	
14	Name Plate A	1	80053	ER1IS9069
15	Bottom Chain Guide	(X)	E6S066075 (1)	E6S066075 (2)
16	Bottom Idle Sheave Assembly	(X)	ER1HS1052 (1)	ER1HS1052 (2)
18	Bottom Shaft Assembly	(X)	E6S5054075 (1)	E6S5054075 (2)
19	Bottom Hook Assembly	1	ER1IS2121	
21	Stopper Screw	1	J1TB01110016	
22	Bearing Cover	1	E6S023100	
23	Thrust Bearing	1	ES022100	
24	Bottom Yoke	1	E6S030100	
26	Latch Kit Assembly	1	M2071100	
27	Snap Ring	1	9047121	
28	Chain Pin	1	E6S041075	

10.5 Bottom Hook Parts 15 & 20 Ton

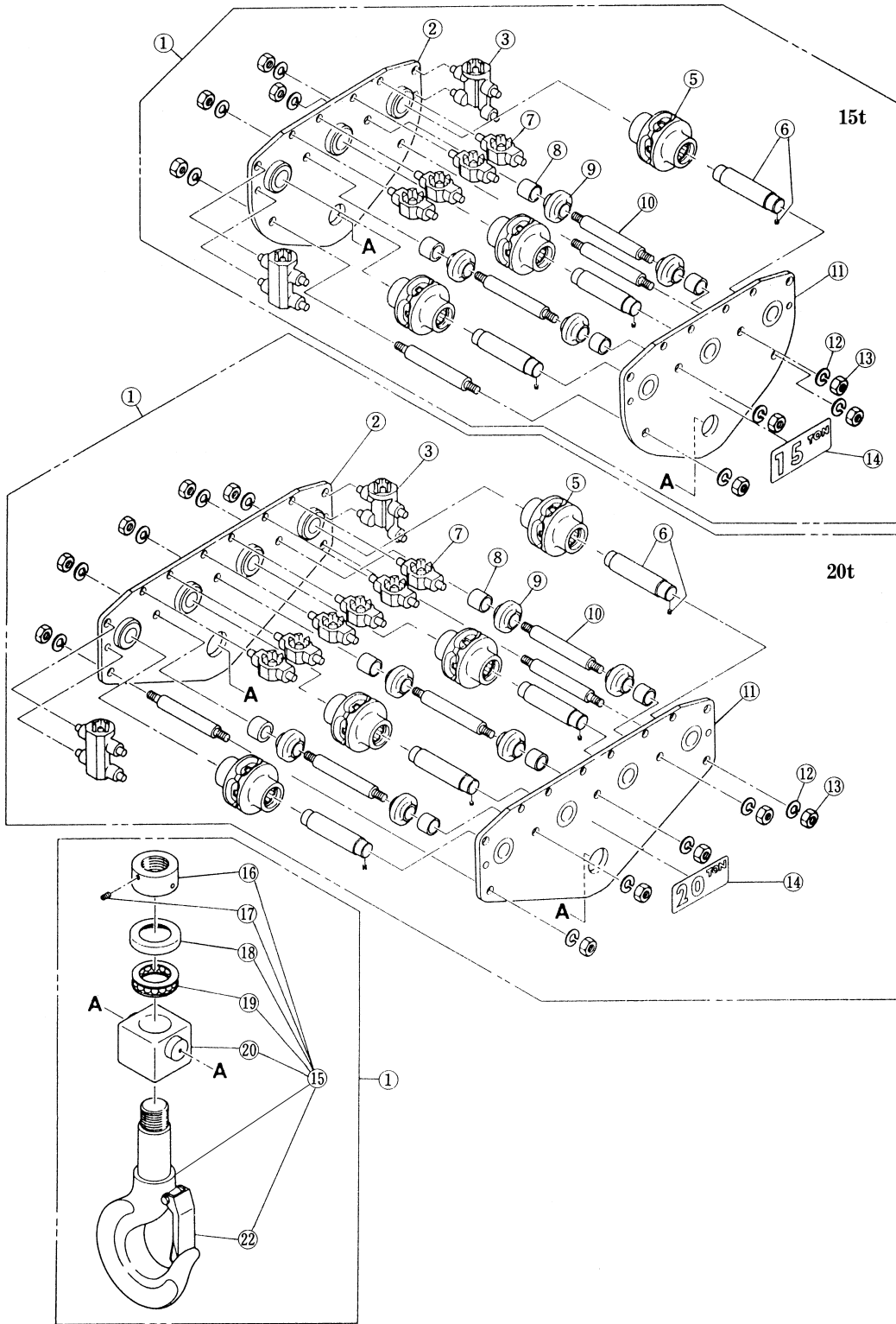

Figure 10-5 Bottom Hook Parts

10.5 Bottom Hook Parts 15 & 20 Ton

Figure No.	Part Name	Parts Per Hoist	150S	200S
1	Bottom Hook Complete Set	1	ER1JS1121	ER1KS1121
2	Bottom Suspension Plate B Assembly	1	E6S5035150	E6S5035200
3	Bottom Chain Guide	2	E6S066150	E6S066150
5	Bottom Idle Sheave Assembly	(X)	ER1HS1052 (3)	ER1HS1052 (4)
6	Bottom Shaft Assembly	(X)	E6S5054075 (3)	E6S5054075 (4)
7	Bottom Cross Guide	(X)	E6S067150 (4)	E6S067150 (6)
8	Bottom Collar	(X)	E6S065150 (4)	E6S065150 (6)
9	Guide Roller	(X)	E6S062075 (4)	E6S062075 (6)
10	Bottom Stay Bolt	(X)	E7S038150 (4)	E7S038150 (7)
11	Bottom Suspension Plate A Assembly	1	ER1JS5034	ER1KS5034
12	Spring Washer	(X)	E6S082075 (8)	E6S082075 (14)
13	Nut	(X)	E6S081075 (8)	E6S081075 (14)
14	Name Plate A	1	ER1JS9069	ER1KS9069
15	Bottom Hook Assembly	1	ER1JS2121	ER1KS2121
16	Hook Nut	1	E6S024150	E6S024200
17	Stopper Screw	1	J1TB01110016	
18	Bearing Cover	1	E6S023150	E6S023200
19	Thrust Bearing	1	ES022150	ES022200
20	Bottom Yoke	1	E6S030150	E6S030200
22	Latch Kit Assembly	1	M2071150	M2071200

10.6 Electric Parts

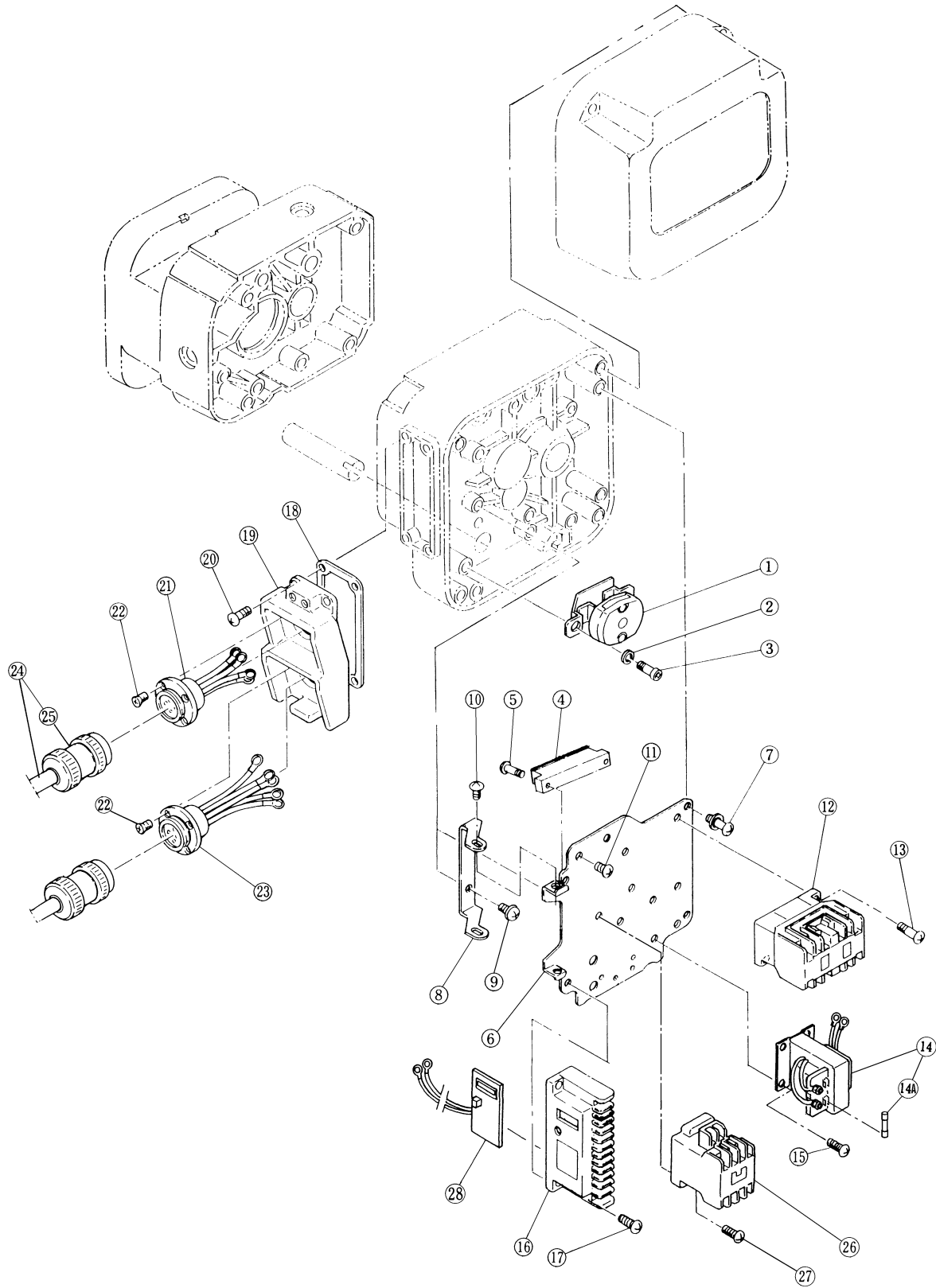

Figure 10-6 Electric Parts

10.6 Electric Parts

Figure No.	Part Name	Parts Per Hoist		080S	100L	Parts Per Hoist		100S	150S	200S
1	Limit Switch Assembly		1	ER1ES2551			2		ER1ES2551	
2	Spring Washer		3	9012709			6		9012709	
3	Socket Bolt		3	9091247			6		9091247	
4	Terminal Plate 6P	S	1	ECP1306AA		S	2		ECP1306AA	
		D	2			D	4			
5	Machine Screw with Spring Washer	S	2	MS556010		S	4		MS556010	
		D	4			D	8			
6	Plate		1	ER1EB9441			2		ER1EB9441	
7	Plate Screw		4	ER1BS9445			8		ER1BS9445	
8	Hinge		1	ER1ES9442			2		ER1ES9442	
9	Machine Screw with Spring Washer		2	E6F151003			4		E6F151003	
10	Pan Head Machine Screw		2	ER1BS9443			4		ER1BS9443	
11	Machine Screw with Spring Washer		2	MS554010			4		MS554010	
12	Electromagnetic Contactor		1	MGC23306B			2		MGC23306B	
13	Machine Screw with Spring Washer		4	MS555010			8		MS555010	
14	Transformer 230/460V		1	TRF63M601			2		TRF63M601	
	Transformer 575V		1	TRF33K601			2		TRF33K601	
14a	Fuse – Secondary 110V		1	9006272			2		9006272	
15	Machine Screw with Spring Washer		4	MS555010			8		MS555010	
16	Terminal Plate 3P		1	ECP1303AA			2		ECP1303AA	
17	Machine Screw with Spring Washer		2	MS555010			4		MS555010	
18	Terminal Cover Packing		1	ER1BS9512			2		ER1BS9512	
19	Socket Holder		1	ER1BS9511			2		ER1BS9511	
20	Machine Screw with Spring Washer		4	ES656003			8		ES656003	
21	Socket 4P Assembly		1	ER1ES1523			2		ER1ES1523	
22	Tapping Flat Head Machine Screw		8	ES558003			16		ES558003	
23	Socket 5P Assembly (Single Speed)	S	1	ER1ES1564		S	2		ER1ES1564	
		D	1	ER1EB1564		D	2		ER1EB1564	
24	Power Supply Cable Assembly (Manual Trolley ONLY)		1	ER1HS1771G						
	Power Supply Cable Assembly (Hook & Lug Mount ONLY)		1	ER1HS1771						
25	Plug 4P		1	ECP2304AA						
26	Electromagnetic Contactor - High Speed	D	1	MGC13226B		D	2		MGC13226B	
27	Machine Screw with Spring Washer	D	2	MS556010		D	4		MS556010	
28	CH Meter - Trans. Secondary = 110V		1	ECP91CHAB			2		ECP91CHAB	

10.7 Push Button Control Station Parts

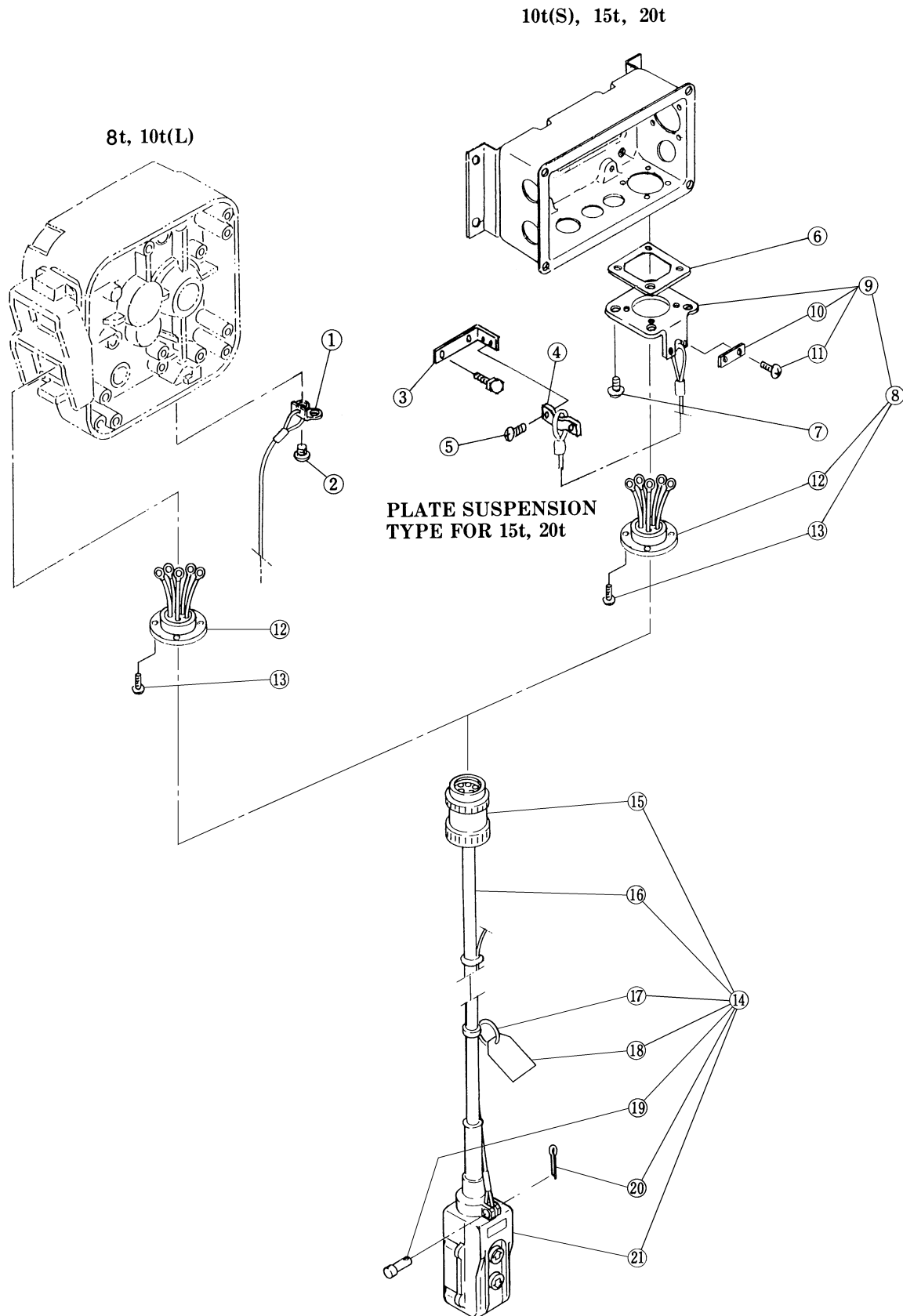
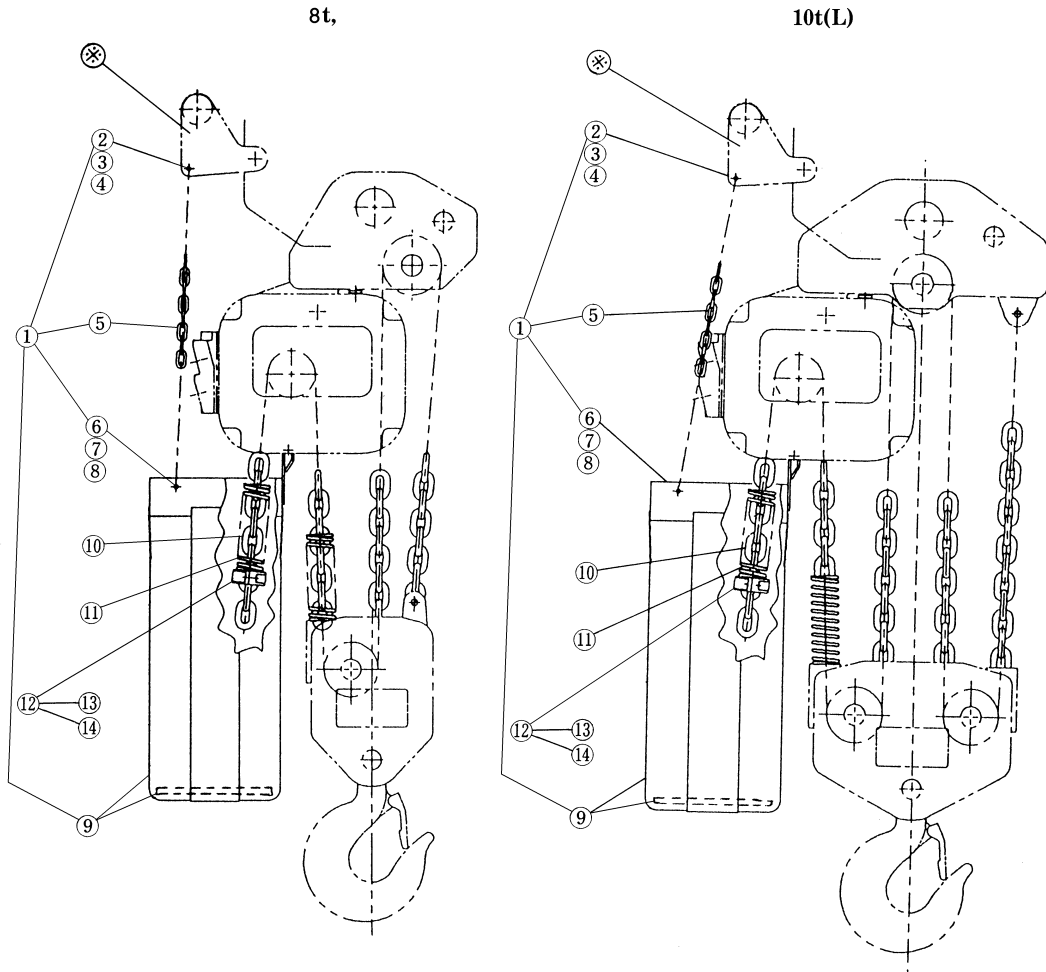

Figure 10-7 Push Button Control Station Parts

10.7 Push Button Control Station Parts

Figure No.	Part Name	Parts Per Hoist		080S	100L	Parts Per Hoist		100S	150S	200S
1	Cord Support Wire Stopper		1	ER1BS9535						
2	Machine Screw with Spring Washer		2	M6F554010						
3	Connection Plate S						1		MR1JS9225	
4	Cord Support Wire Stopper						1	E6L614010S		
5	Machine Screw with Spring Washer						2	E6F151003		
6	Terminal Cover Packing						1	MS527010		
7	Machine Screw with Spring Washer						4	MS554010		
8	Socket 5P Complete Set						1	ER1IS1811		
9	Socket Holder						1	MS529010		
	Cord Chain Stopper						1	M6F530010		
	Machine Screw with Spring Washer						2	MS554010		
12	Socket 5P Assembly		1	ER1ES1564						
13	Tapping Flat Head Machine Screw		4	ES558015			4	ES558015		
14	Push Button Cord 3C Assembly - Hook Mount (8 Ton Lug Mount)	S	1	ER1HS1781		S	1	ER1IS1781	ER1IS1781G	
		D	1	ER1HB1781		D	1	ER1IB1781	ER1IB1781G	
	Push Button Cord 3C Assembly - Hoist w/Push Trolley	S	1	ER1HS1781		S	-			
		D	1	ER1HB1781		D	-			
	Push Button Cord 3C Assembly - Hoist w/Geared Trolley	S	1	ER1HS1781		S	1	ER1IS1781G	ER1JS1781	
		D	1	ER1HB1781		D	1	ER1IB1781G	ER1JB1781	
15	Plug 5P		1	E3S613003			1	E3S613003		
16	Push Button Cord 3C	S	1	16/3P		S	1	16/3P		
		D	1	16/4P		D	1	16/4P		
17	Tag Holder		1	E3S787003			1	E3S787003		
18	Warning Tag PB		1	WTAG7			1	WTAG7		
19	Cord Support Pin B		1	ES628003			1	ES628003		
20	Split Pin		1	9009402			1	9009402		
21	2 Push Button Switch S Assembly	S	1	ES1615S003		S	1	ES1615S003		
		D	1	ECP311BAB		D	1	ECP311BAB		

10.8 Chain Container Parts 8 & 10(L) Ton



※ Refer Trolley Parts List

Figure 10-8 Chain Container Parts 8 & 10(L) Ton

Figure No.	Part Name	Parts Per Hoist	080S	100L
1	Chain Container Kit	1		BK075H2
2	Socket bolt	2		9091274
3	U nut	2		ES857005S
4	Washer	2		ES247005S
5	Container Chain	2		ES875075
6	Socket Bolt	2		9091272
7	U Nut	2		ES857005S
8	Washer	2		ES247005S
9	Chain Container L	1		ER1HS5931
10	Load Chain	FT		LCER025
11	Chain Spring	2		ES047D025
12	Stopper Assembly	2		ES1045025
13	Socket Bolt	2		9091274
14	Spring Washer	2		9012711

10.9 Chain Container Parts 10(S) thru 20 Ton

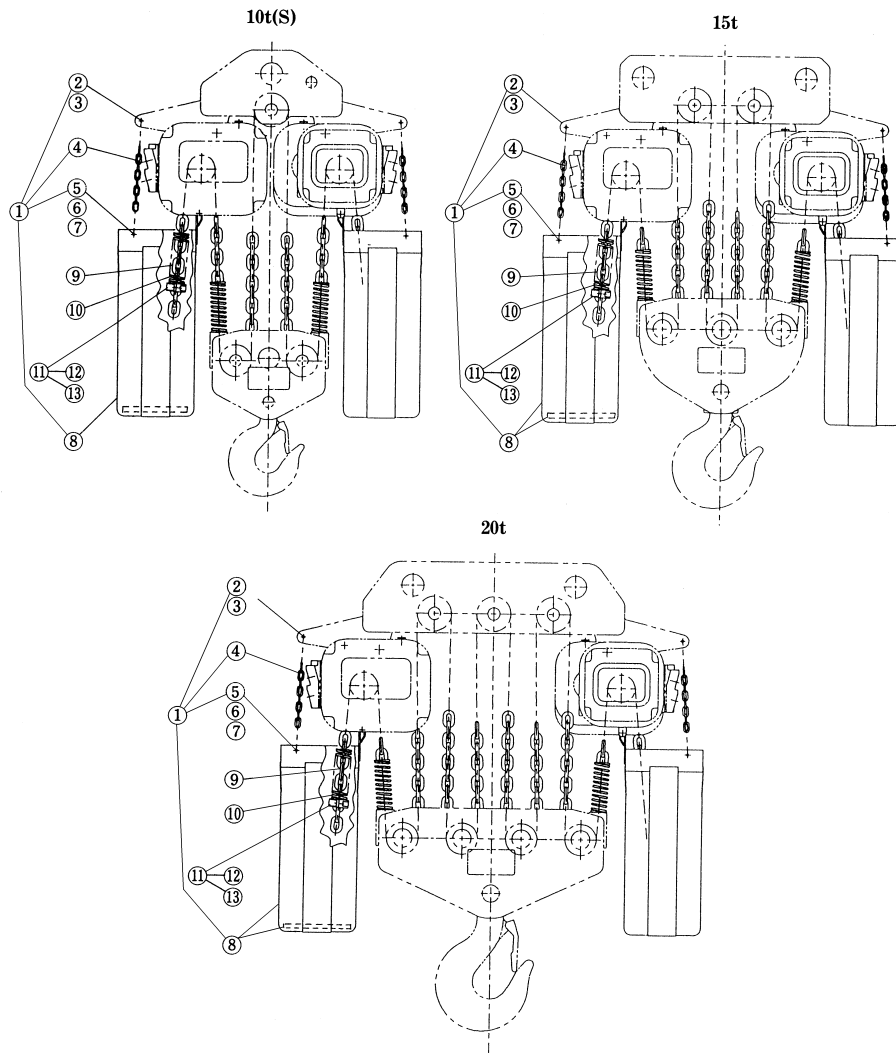

Figure 10-9 Chain Container Parts 10(S) & 20 Ton

Figure No.	Part Name	Parts Per Hoist	100S	150S	200S
1	Chain Container Kit	2		BK100H2	
2	Socket Bolt	2		9091281	
3	U Nut	2		ES857005S	
4	Container Chain	4		ES875100	
5	Socket Bolt	4		9091272	
6	U Nut	4		ES857005S	
7	Washer	4		ES247005S	
8	Chain Container L	2		ER1HS5931	
9	Load Chain	FT		LCER025	
10	Chain Spring	4		ES047D025	
11	Stopper Assembly	4		ES1045025	
12	Socket Bolt	4		9091274	
13	Spring Washer	4		9012711	

10.10 Push or Geared Type Control Station and Cable Parts

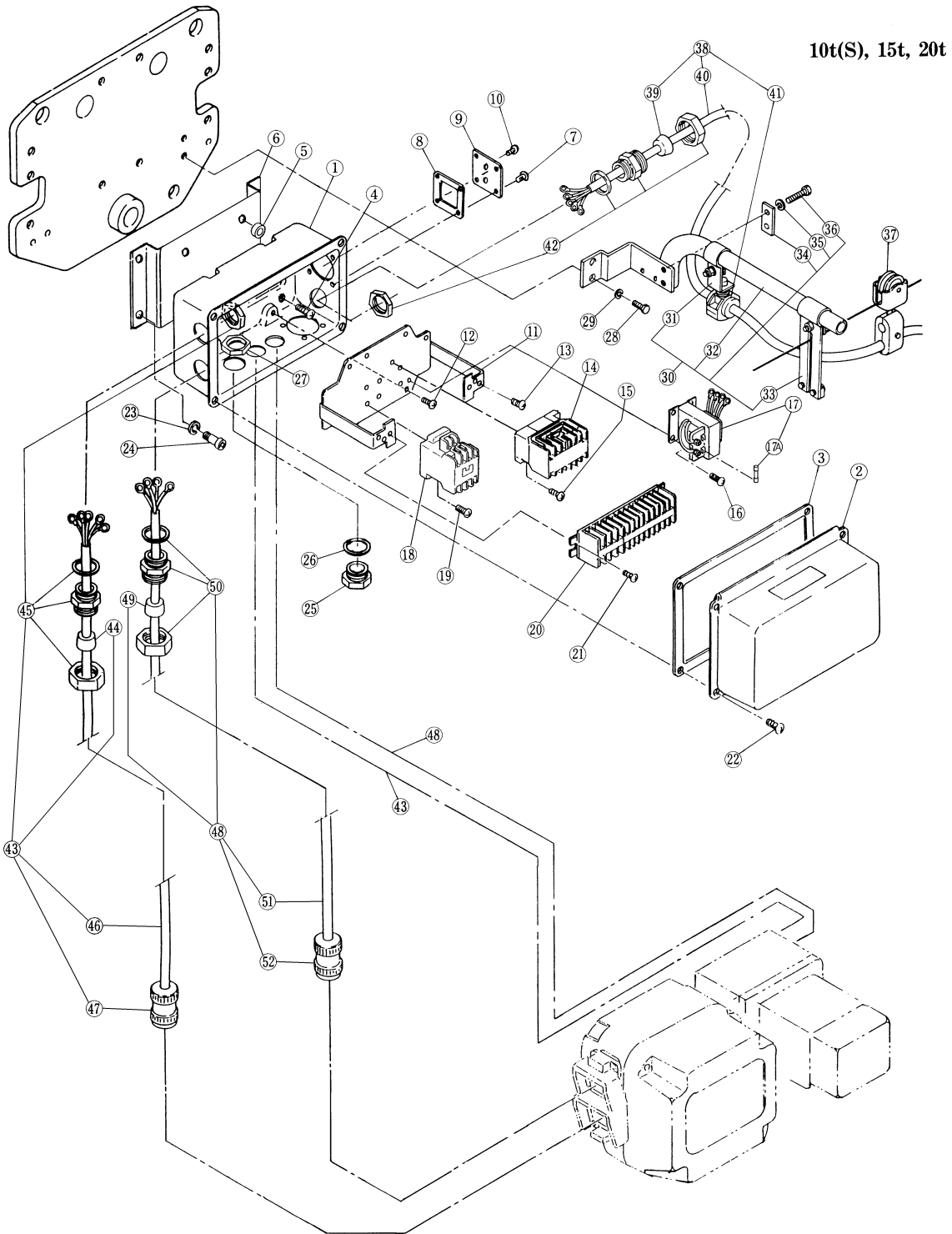

Figure 10-16 Control Station & Cable Parts

10.10 Push or Geared Type Control Station and Cable Parts

Figure No.	Part Name	Parts Per Hoist		100S	150S	200S
1	Switch Box		1		MR1IS9401	
2	Switch Box Lid		1		MR1DS9411	
3	Switch Box Packing		1		MR1DS9421	
4	Machine Screw with Spring Washer		4		MS551010	
5	Spacer		4		MS517010	
6	Plate		1		MR1HS9405	
7	Machine Screw with Spring Washer		4		MS554010	
8	Cord Holder Support Packing		1		MS527010	
9	Cord Cover		1		ER1IS9347	
10	Machine Screw with Spring Washer		2		E6F151003	
11	Plate Assembly	S	1		MR1IS5445	
		D	1		ER1IB5445	
12	Machine Screw with Spring Washer		4		MS554010	
13	Machine Screw with Spring Washer		4		MS555010	
14	Electromagnetic Contactor		1		MGC22306A	
15	Machine Screw with Spring Washer		2		MS556010	
16	Machine Screw with Spring Washer		3		MS555010	
17	Transformer - Primary = 208-230/460V - Secondary = 110V		1		TRF63M601	
	Transformer - Primary = 575V - Secondary = 110V		1		TRF33K601	
18	Electromagnetic Contactor (DUAL SPEED ONLY)	D	1		MGC11226A	
19	Machine Screw with Spring Washer		2		J1AW24001414	
20	Terminal Plate 18p		1		ECP1518AA	
21	Machine Screw with Flat & Spring Washer		2		J1AW24001010	
22	Machine Screw with Spring Washer		4		MS554010	
23	Spring Lock Washer		4		9012711	
24	Socket Bolt		4		9091272	
25	Holder Cover		1		ECP5924AE	
26	Cord Packing		1		ECP5924AC	
27	Holder Nut		1		ECP5924AD	
28	Socket Bolt		2		9093350	
29	Spring Lock Washer		2		9012711	
30	Cable Support Bar Complete Set		1		MR1DS1491	
31	Cable Support Arm		1		MR1DS9492	
32	Cable Support Bar		1		MR1DS9491	
33	Wire Guide Assembly		1		MR1DS1493	
34	Support Bar Holder		1		MR1DS9501	
35	Spring Washer		2		9012712	
36	Bolt		2		9093329	
37	Cable Hanger 21 Assembly		1		MS1733010B	
38	Power Supply Cable Assembly		1		MR1JS1771	
39	Cord Holder Packing		1		ECP6922AA	
40	Power Supply Cable 4C		1		8/4	
41	Cable Support 14		1		M7HE010M1105	
42	Cord Holder A Assembly		1		60704	

10.10 Push or Geared Type Control Station and Cable Parts

Figure No.	Part Name	Parts Per Hoist	100S	150S	200S
43	Cable 4C Complete Set		2	MR1IS1751	MR1JS1751
	Cable Packing		1	ECP6918AA	
	Cord holder A Assembly		1	60704	
	Power Supply Cable 4C		1	12/4	
	Plug 5P		1	E3S613003	
48	Cable 3C Complete Set	S	2	MR1IS1761	MR1JS1761
	Cable 4C Complete Set	D	2	ER1IB1761	ER1JB1761
49	Cable Packing for 3C	S	2	ECP6918AA	
	Cable Packing for 4C	D	2	ECP6914AA	
50	Cable Holder A Assembly		2	60704	
51	S. O. Cord 3C	S	2	16/3	
	S. O. Cord 4C	D	2	16/4P	
52	Plug 5P		2	E3S613003	

This Page Intentionally Left Blank

10.11 Top Suspension Plate parts 8 & 10 Ton

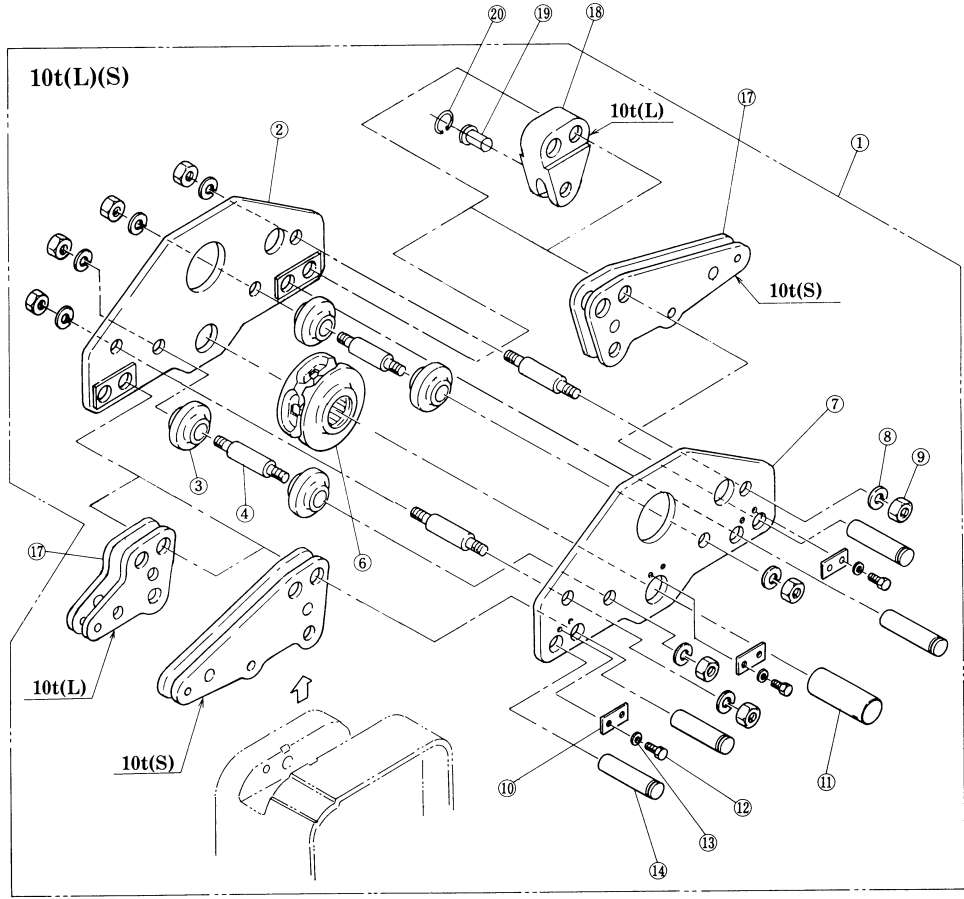
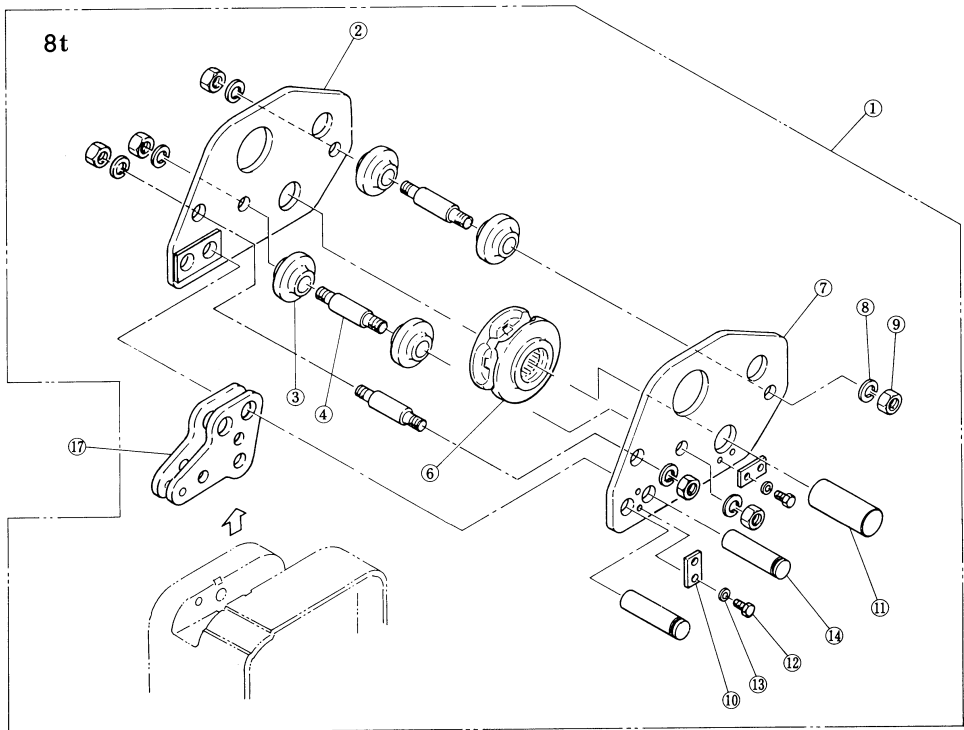

Figure 10-10 Top Suspension Plate Parts 8 & 10 Ton

10.11 Top Suspension Plate parts 8 & 10 Ton

Figure No.	Part Name	Parts Per Hoist	080S	Parts Per Hoist	100L	100S
1	Top Suspension Plate Assembly	1	ER1HS1003	1	ER1IS1003	
2	Top Suspension Plate B Assembly	1	ER1HS5004	1	ER1IS5004	
3	Guide Roller	4	E6S062075	4	E6S062075	
4	Top Stay Bolt	3	E6S007075	4	E6S007075	
6	Top Idle Sheave Assembly	1	ER1HS1051	1	ER1HS1051	
7	Top Suspension Plate A Assembly	1	ER1HS5003	1	ER1IS5003	
8	Spring Washer	6	E6S082075	8	E6S082075	
9	Nut	6	E6S081075	8	E6S081075	
10	Shaft Stopper	2	ER1HS9056	3	ER1HS9056	
11	Top Shaft	1	E6S053075	1	E6S053075	
12	Socket Bolt	4	9091271	6	9091271	
13	Spring Washer	4	9012711	6	9012711	
14	Suspender Shaft	2	E6S008075	4	E6S008075	
17	Connection Yoke Assembly	1	ER1HS5005	(X)	ER1HS5005 (1)	ER1IS5005 (2)
18	Chain Holder			1	ER1IL9017	
19	Chain Pin			1	E6S041075	
20	Snap Ring			1	9047121	

10.12 Top Suspension Plate Parts 15 & 20 Ton

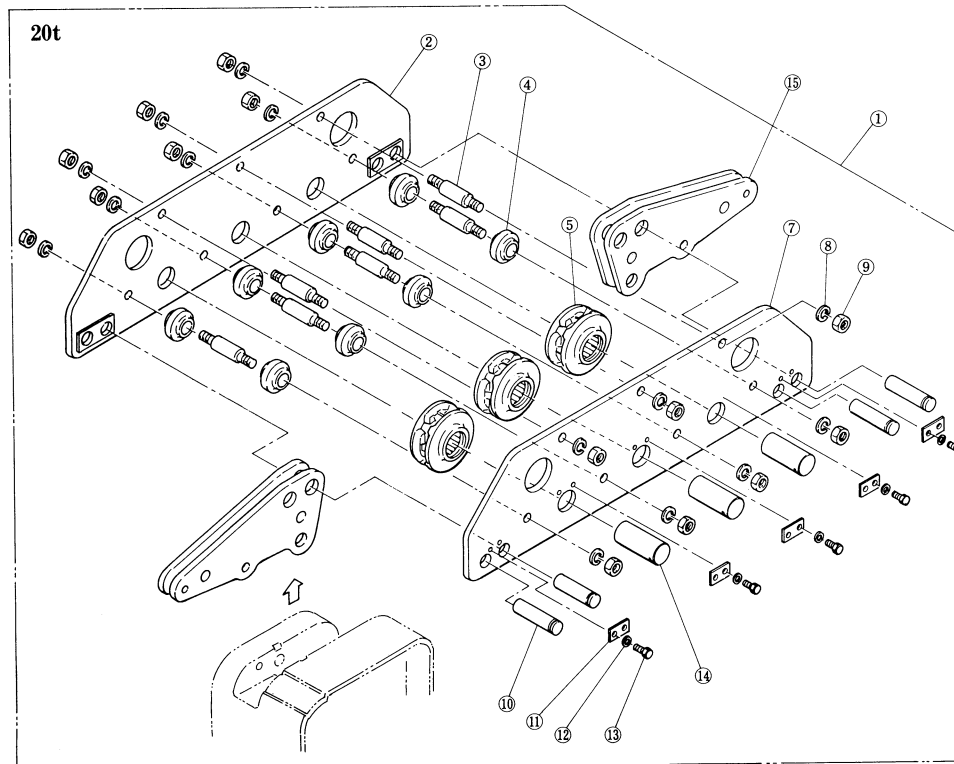
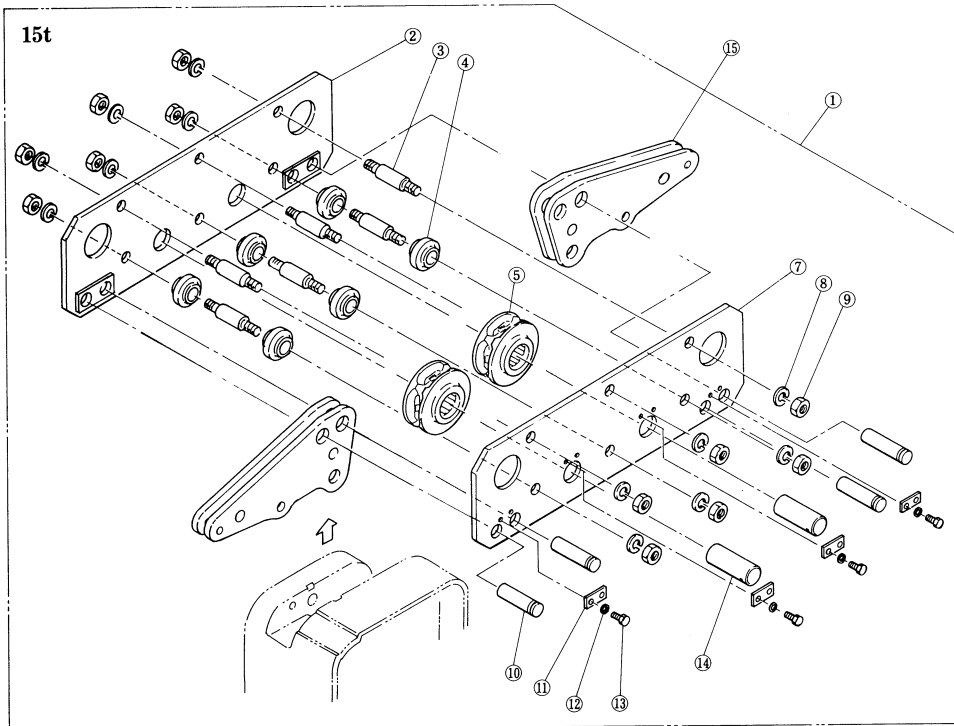

Figure 10-11 Top Suspension Plate Parts 15 & 20 Ton

10.12 Top Suspension Plate Parts 15 & 20 Ton

Figure No.	Part Name	Parts Per Hoist	150S	Parts Per Hoist	200S
1	Top Suspension Plate Assembly	1	ER1JS1003	1	ER1KS1003
2	Top Suspension Plate B	1	ER1JS5004	1	ER1KS5004
3	Top Stay Bolt	6	E6S007075	7	E6S007075
4	Guide Roller	6	E6S062075	8	E6S062075
5	Top Idle Sheave Assembly	2	ER1HS1051	3	ER1HS1051
7	Top Suspension Plate A	1	ER1JS5003	1	ER1KS5003
8	Spring Washer	12	E6S082075	14	E6S082075
9	Nut	12	E6S081075	14	E6S081075
10	Suspender Shaft	4	E6S008075	4	E6S008075
11	Shaft Stopper	4	ER1HS9056	5	ER1HS9056
12	Spring Washer	5	9012711	10	9012711
13	Socket Bolt	5	9091271	10	9091271
14	Top Shaft	2	E6S053075	3	E6S053075
15	Connection Yoke Assembly	2	ER1IS5005	2	ER1IS5005

10.13 Hook Type Control Station and Cable Parts

10t(S), 15t, 20t

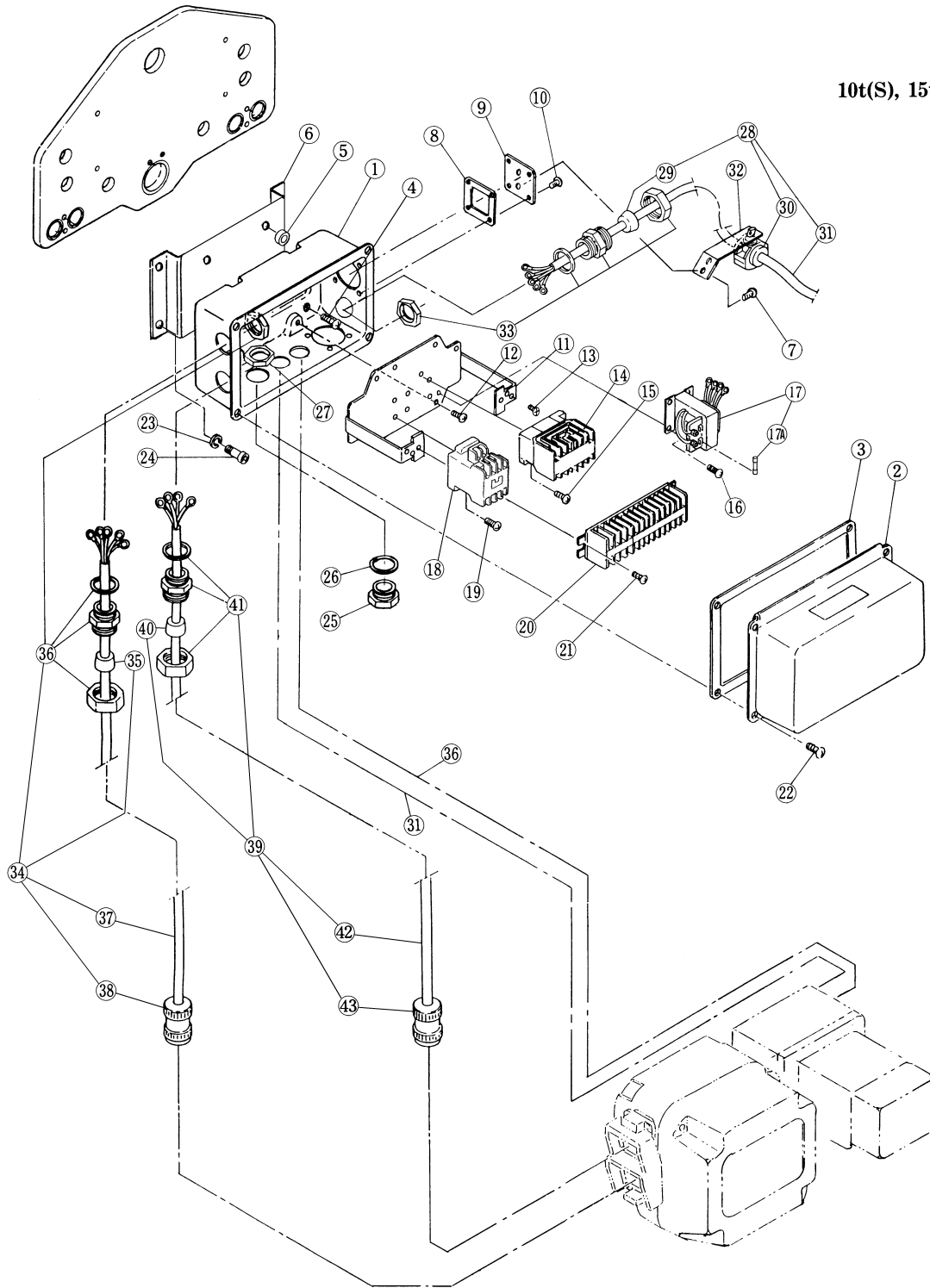

Figure 10-12 Hook Type Control Station and Cable Parts

10.13 Hook Type Control Station and Cable Parts

Figure No.	Part Name	Parts Per Hoist	100S	150S	200S
1	Switch Box	1		MR1IS9401	
2	Switch Box Lid	1		MR1DS9411	
3	Switch Box Packing	1		MR1DS9421	
4	Machine Screw with Spring Washer	4		MS551010	
5	Spacer	4		MS517010	
6	Plate	1		MR1HS9405	
7	Machine Screw with Spring Washer	2		E6F151003	
8	Cord Holder Support Packing	1		MS527010	
9	Cord Cover	1		ER1IS9347	
10	Machine Screw with Spring Washer	4		MS554010	
11	Plate Assembly	S	1	MR1IS5445	
		D	1	ER1IB5445	
12	Machine Screw with Spring Washer	4		MS554010	
13	Machine Screw with Spring Washer	4		MS555010	
14	Electromagnetic Contactor	1		MGC22306A	
15	Machine Screw with Spring Washer	2		MS556010	
16	Machine Screw with Spring Washer	3		MS555010	
17	Transformer - Primary = 208-230/460V - Secondary =110V	1		TRF62M601	
	Transformer - Primary = 575V - Secondary =110V	1		TRF33K601	
17A	Fuse - Trans. Secondary =110V	1		9006272	
18	Electromagnetic Contactor (DUAL SPEED ONLY)	D	1	MGC11226A	
19	Machine Screw with Spring Washer	D	2	J1AW24001414	
20	Terminal Plate 18p	1		ECP1518AA	
21	Machine Screw with Spring Washer	2		J1AW24001010	
22	Machine Screw with Spring Washer	4		MS554010	
23	Spring Lock Washer	4		9012711	
24	Socket Bolt	4		9091272	
25	Holder Cover	1		ECP5924AE	
26	Cord Packing	2		ECP5924AC	
27	Holder Nut	1		ECP5924AD	
28	Power Supply Cable 4C Assembly	1		MR1JS1771	
29	Cord Holder Packing	1		ECP6922AA	
30	Cable Support 14	1		M7HE010M1105	
31	Power Supply Cable 4C	1		8/4	
32	Cable Support Arm	1		ER1IS9431	
33	Cable Holder A Assembly	1		60704	
34	Cable 4C Complete Set	2	MR1IS1751	MR1JS1751	
35	Cable Packing	2		ECP6916AA	
36	Cord Holder A Assembly	2		60704	
37	Power Supply Cable 4C	2		12/4	
38	Plug 4P	2		ECP2304AA	
39	Cable 3C Complete Set	S	2	MR1IS1761	MR1JS1761
	Cable 4C Complete Set	D	2	ER1IB1761	ER1JB1761
40	Cable Packing for 3C	S	2	ECP6918AA	
	Cable Packing for 4C	D	2	ECP6914AA	
41	Cord Holder A Assembly	2		60704	
42	S. O. Cord 3C	S	2	16/3	
	S. O. Cord 4C	D	2	16/4P	
43	Plug 5P	2		E3S613003	

10.14 Top Hook Parts

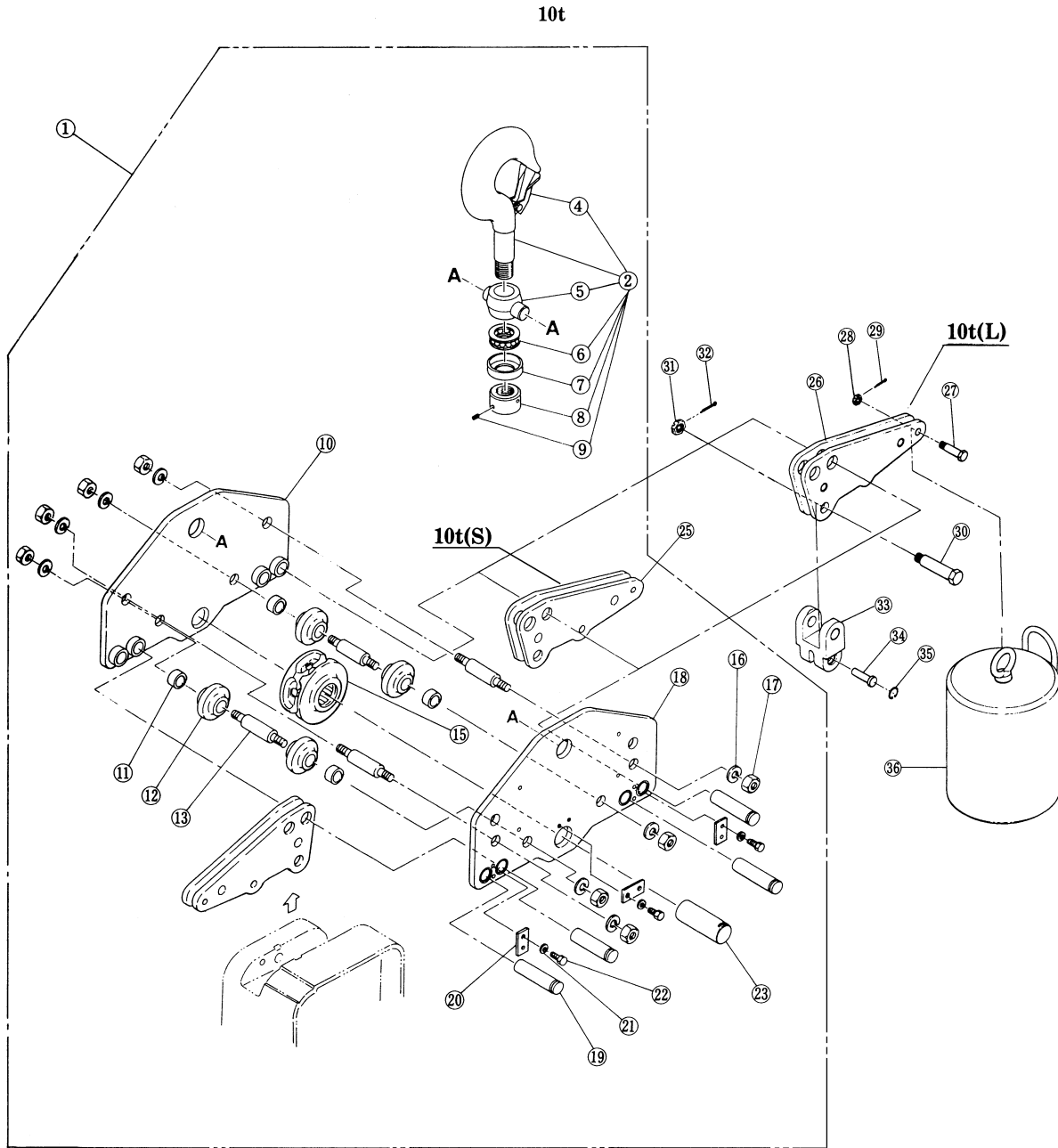

Figure 10-13 Top Hook Parts 10 Ton

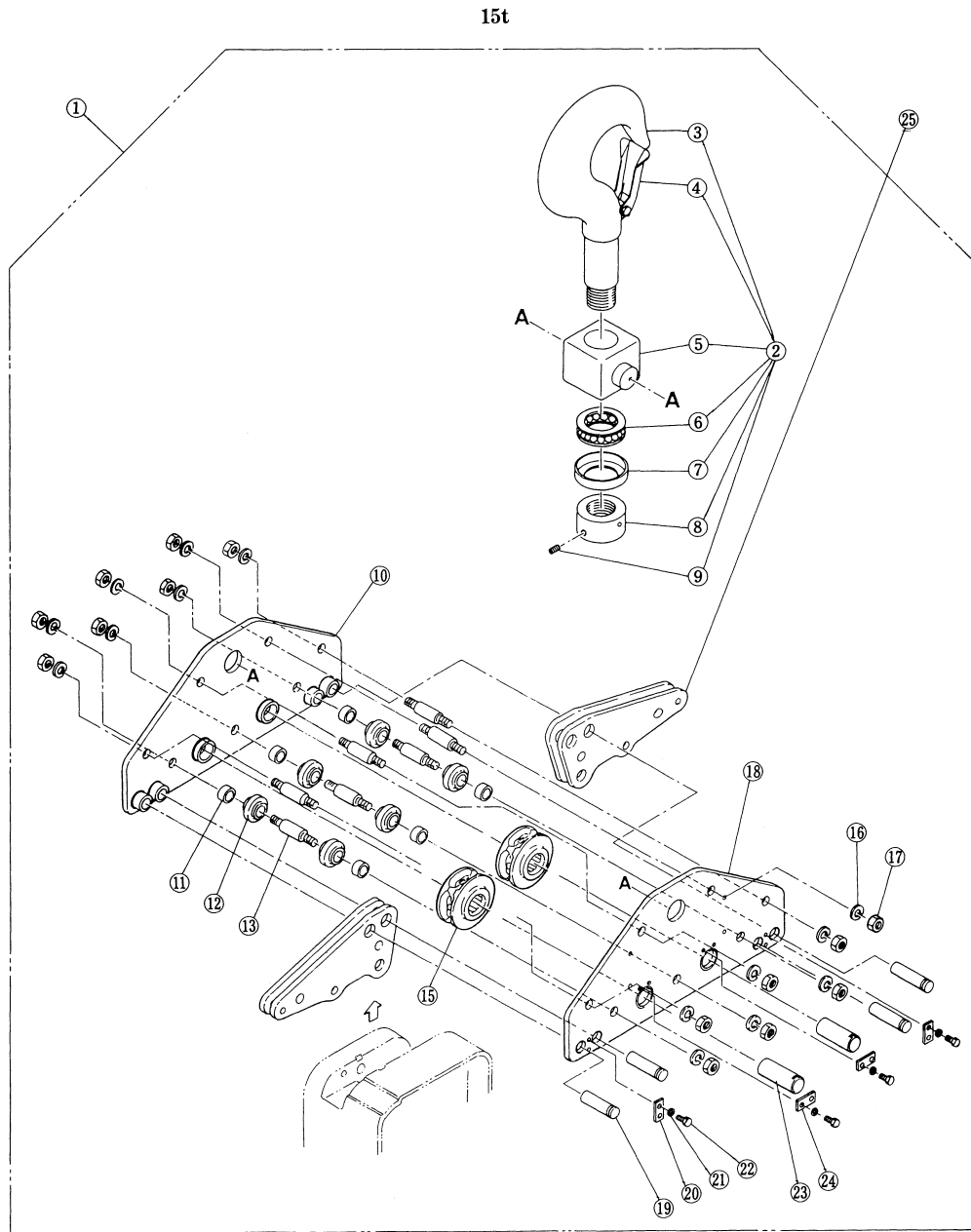

Figure 10-14 Top Hook Parts 15 Ton

10.14 Top Hook Parts

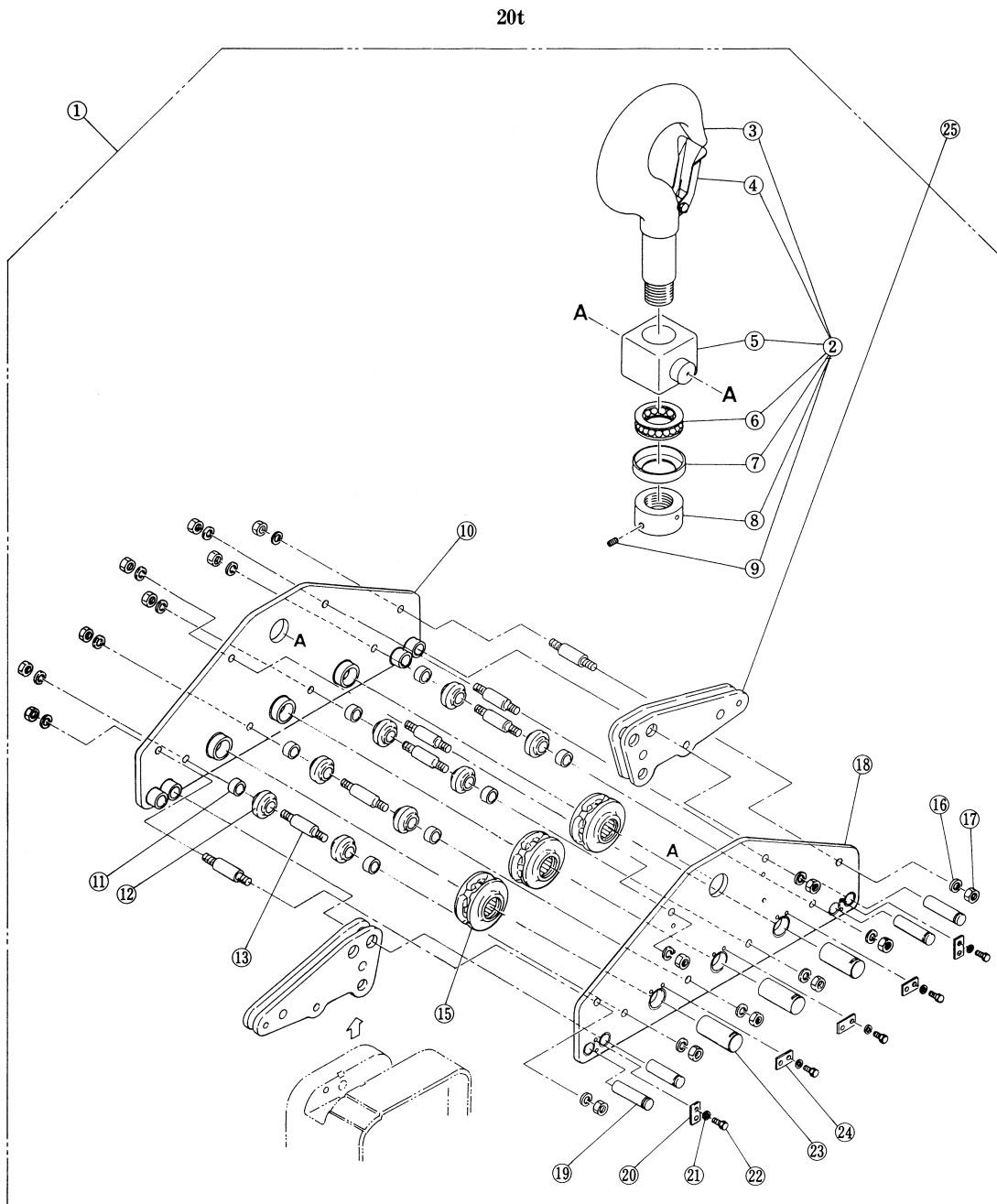

Figure 10-15 Top Hook Parts 20 Ton

10.14 Top Hook Parts

Figure No.	Part Name	Parts Per Hoist	100L	100S	150S	200S
1	Top Hook Complete Set	1	ER1IS1011		ER1JS1011	ER1KS1011
2	Bottom Hook Assembly	1	ER1IS2121		ER1JS2121	ER1KS2121
4	Latch Kit Assembly	1	M2071100		M2071150	M2071200
5	Bottom Yoke	1	E6S030100		E6S030150	E6S030200
6	Thrust Bearing	1	E6S022100		ES022150	ES022200
7	Bearing Cover	1	E6S023100		E6S023150	E6S023200
8	Hook Nut	1	E6S024100		E6S024150	E6S024200
9	Stopper Screw	1	J1TB01110016			
10	Top Suspension Plate B	1	ER1IS5012		ER1JS5012	ER1KS5012
11	Bottom Collar	(X)	E6S065075 (4)		E6S065150 (6)	E6S065150 (8)
12	Guide Roller	(X)	E6S062075 (4)		E6S062075 (6)	E6S062075 (8)
13	Bottom Stay Bolt	(X)	E6S038075 (4)		E6S038150 (7)	E6S038150 (8)
15	Bottom Idle Sheave Assembly	(X)	ER1HS1052 (1)		ER1HS1052 (2)	ER1HS1052 (3)
16	Spring Washer	(X)	E6S082075 (8)		E6S082075 (14)	E6S082075 (16)
17	Nut	(X)	E6S081075 (8)		E6S081075 (14)	E6S081075 (16)
18	Top Suspension Plate A Assembly	1	ER1IS5011		ER1JS5011	ER1KS5011
19	Suspender Shaft B	4	E6S013100		E6S013150	
20	Shaft Stopper A	(X)	ER1IS9056 (3)		ER1IS9056 (2)	
21	Spring Washer	(X)	9012711 (6)		9012711 (8)	9012711 (10)
22	Socket Bolt	(X)	9091271 (6)		9091271 (8)	9091271 (10)
23	Top Shaft B	(X)	E6S057100 (1)		E6S057150 (2)	E6S057150 (3)
24	Shaft Stopper B	(X)			ER1JS9060 (2)	ER1JS9060 (3)
25	Connection Yoke Assembly	(X)	ER1HS5005 (1)		ER1IS5005 (2)	
26	Connection Yoke Assembly	1	ER1IL5155			
27	Chain Pin	1	ES041050			
28	Slotted Nut	1	M2049030			
29	Split Pin	1	90094145			
30	Yoke Bolt	1	ER1ES9032			
31	Slotted Nut	1	ES088020L			
32	Split Pin	1	9009436			
33	Chain Holder L	1	ER1IL9171			
34	Chain Pin	1	E6S041075			
35	Snap Ring	1	9047121			
36	Balance Weight Assembly	1	ER1IL5175			



www.harringtonhoists.com

Harrington Hoists, Inc.
401 West End Avenue
Manheim, PA 17545
Phone: 717-665-2000
Toll Free: 800-233-3010
Fax: 717-665-2861

Harrington Hoists – Western Division
2341 Pomona Rincon Rd. #103
Corona, CA 92880-6973
Phone: 909-279-7100
Toll Free: 800-317-7111
Fax: 909-279-7500

ERLC4.7HPMotorSup