

---

# OWNER'S MANUAL

---

## **ELECTRIC CHAIN HOIST ER and NER SERIES**

1/8 Ton through 5 Ton Capacity

Code, Lot and Serial Number

### **⚠ WARNING**

This equipment should not be installed, operated or maintained by any person who has not read and understood all the contents of this manual. Failure to read and comply with the contents of this manual can result in serious bodily injury or death, and/or property damage.

**HARRINGTON**  
HOISTS AND CRANES

# Table of Contents

<b>Section</b>	<b>Page Number</b>
1.0 Important Information and Warnings .....	4
1.1 Terms and Summary	
1.2 Warning Tags and Labels	
2.0 Technical Information.....	8
2.1 Specifications	
2.2 Dimensions	
2.3 Hot Metal Applications	
3.0 Preoperational Procedures .....	12
3.1 Fill Gear Box with Oil	
3.2 Chain	
3.3 Mounting Location	
3.4 Mounting the Hoist	
3.5 Electrical Connections	
3.6 Preoperational Checks and Trial Operation	
4.0 Operation .....	19
4.1 Introduction	
4.2 Shall's and Shall Not's for Operation	
4.3 Hoist Controls	
5.0 Inspection .....	22
5.1 General	
5.2 Inspection Classification	
5.3 Frequent Inspection	
5.4 Periodic Inspection	
5.5 Occasionally Used Hoists	
5.6 Inspection Records	
5.7 Inspection Methods and Criteria	

<b>Section</b>	<b>Page Number</b>
6.0 Maintenance & Handling .....	29
6.1 Count/Hour Meter	
6.2 Lubrication	
6.3 Motor Brake	
6.4 Load Chain	
6.5 Friction Clutch and Mechanical Load Brake with Friction Clutch	
6.6 Storage	
6.7 Outdoor Installation	
7.0 Troubleshooting .....	35
8.0 Material Safety Data Sheets .....	38
8.1 ER Model Gear Box Oil	
8.2 NER Model Gear Box Oil	
8.3 (N)ER Model Load Chain Grease	
9.0 Warranty .....	51
10.0 Parts List .....	53

## 1.0 Important Information and Warnings

### 1.1 Terms and Summary

**This manual provides important information** for personnel involved with the installation, operation and maintenance of this product. Although you may be familiar with this or similar equipment, it is strongly recommended that you read this manual before installing, operating or maintaining the product.

#### Danger, Warning, Caution and Notice

Throughout this manual there are steps and procedures that can present hazardous situations. The following signal words are used to identify the degree or level of hazard seriousness.

**⚠ DANGER** Danger indicates an imminently hazardous situation which, if not avoided, **will** result in **death or serious injury**, and property damage.

**⚠ WARNING** Warning indicates an imminently hazardous situation which, if not avoided, **could** result in **death or serious injury**, and property damage.

**⚠ CAUTION** Caution indicates a potentially hazardous situation which, if not avoided, **may** result **minor or moderate injury** or property damage.

**NOTICE** Notice is used to notify people of installation, operation, or maintenance information which is important but not directly hazard-related.

### ⚠ CAUTION

These general instructions deal with the normal installation, operation, and maintenance situations encountered with the equipment described herein. The instructions should not be interpreted to anticipate every possible contingency or to anticipate the final system, crane, or configuration that uses this equipment. For systems using the equipment covered by this manual, the supplier and owner of the system are responsible for the system's compliance with all applicable industry standards, and with all applicable federal, state and local regulations/codes.

This manual includes instructions and parts information for a variety of hoist types. Therefore, all instructions and parts information may not apply to any one type or size of specific hoist. Disregard those portions of the instructions that do not apply.

Record your hoist's Code, Lot and Serial Number (see section 10) on the front cover of this manual for identification and future reference to avoid referring to the wrong manual for information or instructions on installation, operation, inspection, maintenance, or parts.

Use only Harrington authorized replacement parts in the service and maintenance of this hoist.

## **WARNING**

Equipment described herein is not designed for and **MUST NOT** be used for lifting, supporting, or transporting people, or for lifting or supporting loads over people.

Equipment described herein should not be used in conjunction with other equipment unless necessary and/or required safety devices applicable to the system, crane, or application are installed by the system designer, system manufacturer, crane manufacturer, installer, or user.

Modifications to upgrade, rerate, or otherwise alter this equipment shall be authorized only by the original equipment manufacturer.

Equipment described herein may be used in the design and manufacture of cranes or monorails. Additional equipment or devices may be required for the crane and monorail to comply with applicable crane design and safety standards. The crane designer, crane manufacturer, or user is responsible to furnish these additional items for compliance. Refer to ANSI/ASME B30.17, "Safety Standard for Top-Running Single Girder Cranes"; ANSI/ASME B30.2 "Safety Standard for Top-Running Double-Girder Cranes"; and ANSI/ASME B30.11 "Safety Standard for Underhung Cranes and Monorails".

If a below-the-hook lifting device or sling is used with a hoist, refer to ANSI/ASME B30.9, "Safety Standard for Slings" or ANSI/ASME B30.20, "Safety Standard for Below-the-Hook Lifting Devices".

Hoists and cranes, used to handle hot molten material may require additional equipment or devices. Refer to ANSI Z241.2, "Safety Requirements for Melting and Pouring of Metals in the Metalcasting Industry".

Electrical equipment described herein is designed and built in compliance with Harrington's interpretation of ANSI/NFPA 70, "National Electrical Code". The system designer, system manufacturer, crane designer, crane manufacturer, installer, or user is responsible to assure that the installation and associated wiring of these electrical components is in compliance with ANSI/NFPA 70, and all applicable Federal, State and Local Codes.

Failure to read and comply with any one of the limitations noted herein can result in serious bodily injury or death, and/or property damage.

## **DANGER**

**HAZARDOUS VOLTAGES ARE PRESENT IN THE CONTROL BOX, OTHER ELECTRICAL COMPONENTS, AND CONNECTIONS BETWEEN THESE COMPONENTS.**

Before performing ANY mechanical or electrical maintenance on the equipment, de-energize (disconnect) the main switch supplying power to the equipment; and lock and tag the main switch in the de-energized position. Refer to ANSI Z244.1, "Personnel Protection – Lockout/Tagout of Energy Sources".

Only trained and competent personnel should inspect and repair this equipment.

## **NOTICE**

It is the responsibility of the owner/user to install, inspect, test, maintain, and operate a hoist in accordance with ANSI/ASME B30.16, "Safety Standard for Overhead Hoists", OSHA Regulations and ANSI/NFPA 70, National Electric Code. If the hoist is installed as part of a total lifting system, such as an overhead crane or monorail, it is also the responsibility of the owner/user to comply with the applicable ANSI/ASME B30 volume that addresses that type of equipment.

It is the responsibility of the owner/user to have all personnel that will install, inspect, test, maintain, and operate a hoist read the contents of this manual and applicable portions of ANSI/ASME B30.16, "Safety Standard for Overhead Hoists", OSHA Regulations and ANSI/NFPA 70, "National Electric Code". If the hoist is installed as part of a total lifting system, such as an overhead crane, the applicable ANSI/ASME B30 volume that addresses that type of equipment must also be read by all personnel.

If the hoist owner/user requires additional information, or if any information in the manual is not clear, contact Harrington or the distributor of the hoist. Do not install, inspect, test, maintain, or operate this hoist unless this information is fully understood.

A regular schedule of inspection of the hoist in accordance with the requirements of ANSI/ASME B30.16 should be established and records maintained.

## 1.2 Warning Tags and Labels

The warning tag illustrated below in [Figure 1-1](#) is supplied with each hoist shipped from the factory. If the tag is not attached to your hoist's pendant cord, order a tag from your dealer and install it. Read and obey all warnings attached to this hoist. Tag is not shown actual size.

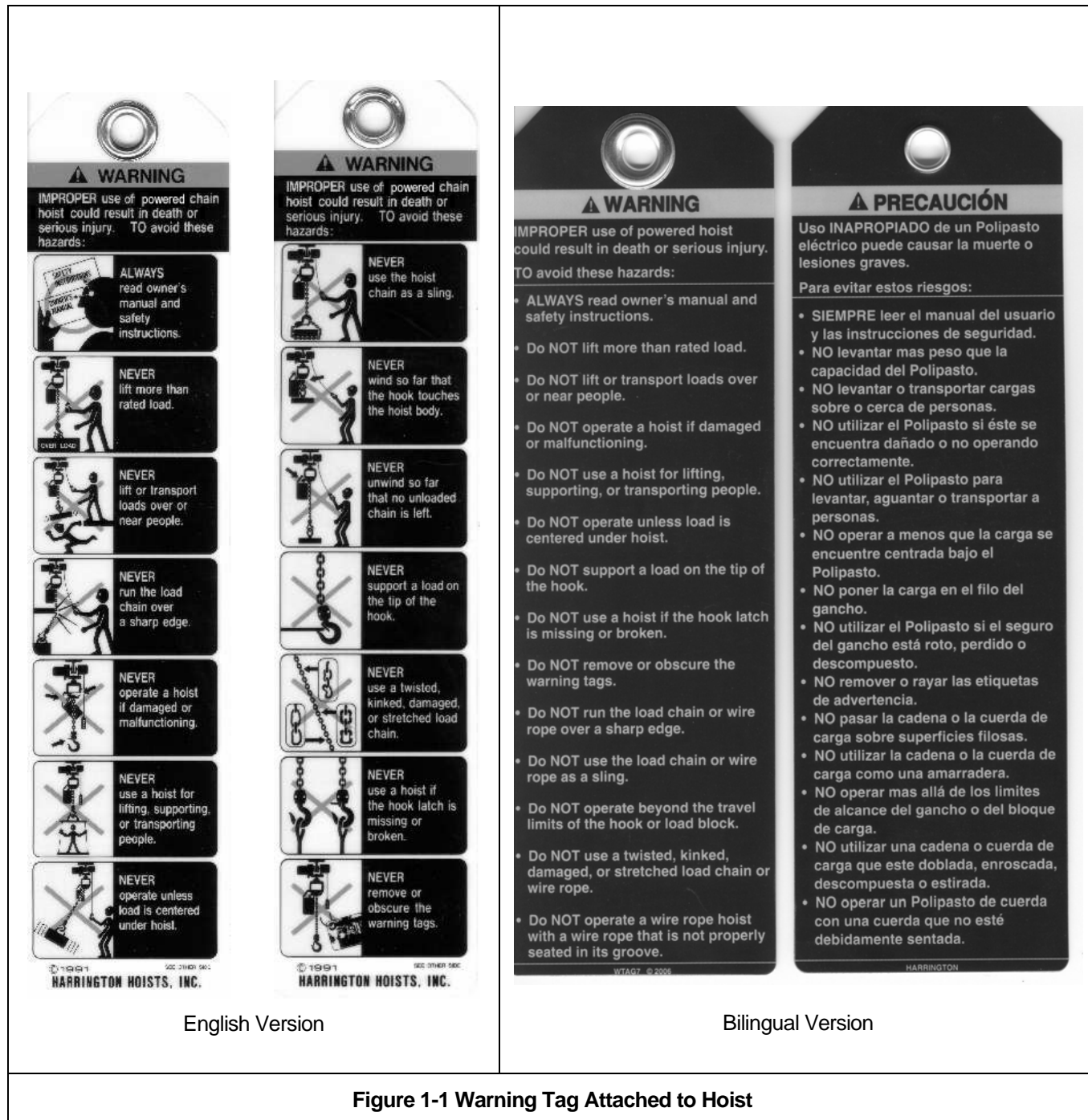
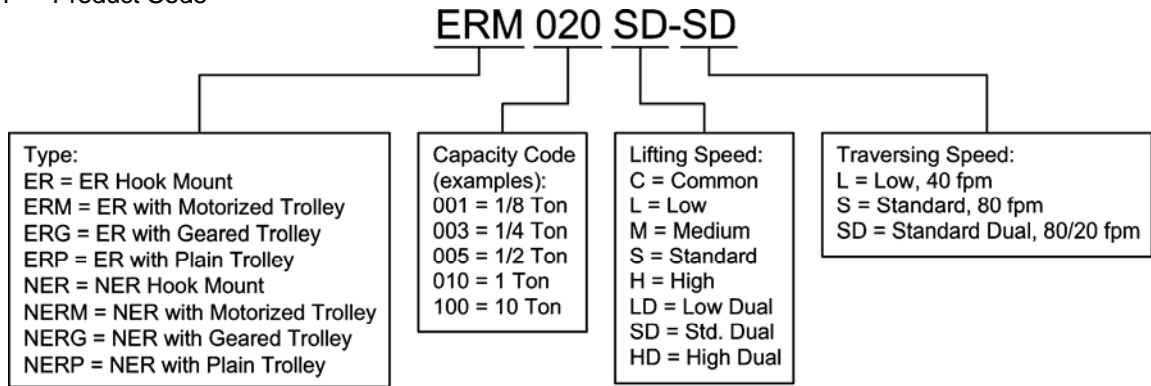

Figure 1-1 Warning Tag Attached to Hoist

## 2.0 Technical Information

### 2.1 Specifications

#### 2.1.1 Product Code



2.1.2 ER and NER Models - Harrington ER series hoist are available in two versions, the ER and NER. These two versions are equipped with different options as standard equipment. The NER has a friction clutch mechanism that provides over winding protection. The ER has a mechanical load brake/friction clutch combination and an electronic count/hour meter in the control circuit. Refer to [Figure 2-1](#) for the visual differences between the ER and NER.

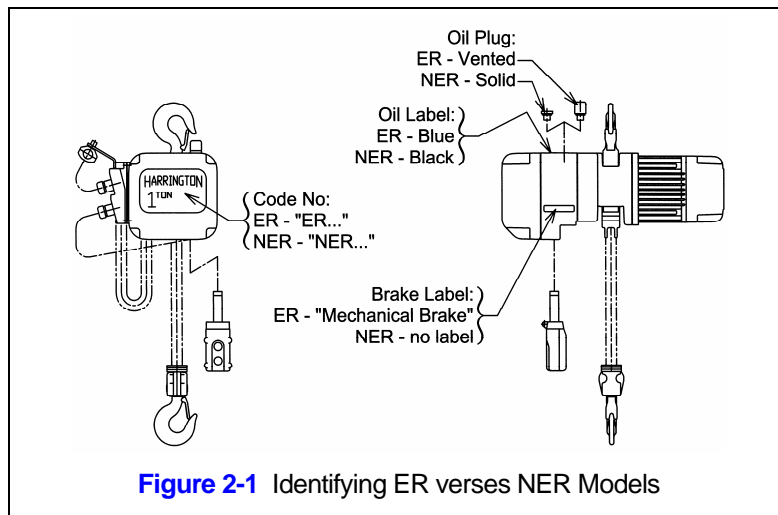

#### 2.1.3 Operating Conditions and Environment

Temperature range: -4° to +104°F (-20° to +40°C)

Humidity: 85% or less

Enclosure Rating: Hoist Meets IP 55, Pendant Meets IP65

Supply Voltage: Standard 208-230/460V-3-60, Optional 575V-3-60, Special Voltages Available

	Single Speed	Dual Speed
ASME Duty Classification:	H4	H4
Intermittent Duty Rating:	60% ED 360 starts per hour	40/20% ED 120/240 starts per hour
Short Time Duty Rating:	60 min.	30/10 min.

**Table 2-1 Hoist Specifications**

Capacity (Ton)	Code	Lifting Speed (ft/min)	Motor			Load Chain Wire Diameter (mm) x Chain Fall Lines	Load Sheave Pockets	Net Weight (lbs)	Weight for One Addnl. FT. of Lift (lbs)	
			Output (Hp)	Current Draw (amps)						
				208V or 230V	460V					
SINGLE SPEED	1/8	(N)ER001H	57	0.75	4.2	2.1	5.0 x 1	5	68	0.37
	1/4	(N)ER003S	39	0.75	4.2	2.1	5.0 x 1	5	68	0.37
	1/4	(N)ER003H	60	1.2	5.7	2.9	6.3 x 1	5	84	0.57
	1/2	(N)ER005L	15	0.75	4.2	2.1	6.3 x 1	4	70	0.57
	1/2	(N)ER005S	30	1.2	5.7	2.9	6.3 x 1	5	84	0.57
	1	(N)ER010L	16	1.2	5.7	2.9	8.0 x 1	4	90	0.93
	1	NER010M	24	1.9	7.3	3.7	8.0 x 1	4	110	0.93
	1	(N)ER010S	29	2.4	10.5	5.3	8.0 x 1	5	134	0.93
	1 1/2	(N)ER015S	20	2.4	10.5	5.3	10.0 x 1	4	152	1.5
	2	(N)ER020L	14	2.4	10.5	5.3	10.0 x 1	4	154	1.5
	2	NER020M	24	3.8	14.9	7.5	10.0 x 1	4	181	1.5
	2	(N)ER020S	28	4.7	18.3	9.2	10.0 x 1	5	240	1.5
	2 1/2	(N)ER025S	23	4.7	18.3	9.2	11.2 x 1	4	247	1.9
	3	NER030C	12	3.8	14.9	7.5	10.0 x 2	4	216	3.1
	3	(N)ER030L	16	4.7	18.3	9.2	12.5 x 1	4	256	2.3
	3	(N)ER030S	22	6.2	25.1	12.6	12.5 x 1	4	269	2.3
5	(N)ER050L	12	4.7	18.3	9.2	11.2 x 2	4	306	4.0	
DUAL SPEED	1/8	(N)ER001HD	58/19	0.6/0.2	2.9/2.4	1.5/1.2	5.0 x 1	5	79	0.37
	1/4	(N)ER003SD	29/10	0.6/0.2	2.9/2.4	1.5/1.2	5.0 x 1	5	79	0.37
	1/4	(N)ER003HD	60/20	1.2/0.4	5.7/5.1	2.9/2.6	6.3 x 1	5	104	0.57
	1/2	(N)ER005LD	14/5	0.6/0.2	2.9/2.4	1.5/1.2	6.3 x 1	4	84	0.57
	1/2	(N)ER005SD	30/10	1.2/0.4	5.7/5.1	2.9/2.6	6.3 x 1	5	104	0.57
	1	(N)ER010LD	14/5	1.2/0.4	5.7/5.1	2.9/2.6	8.0 x 1	4	108	0.93
	1	(N)ER010SD	29/10	2.4/0.8	9.1/5.7	4.6/2.9	8.0 x 1	5	152	0.93
	1 1/2	(N)ER015SD	20/7	2.4/0.8	9.1/5.7	4.6/2.9	10.0 x 1	4	165	1.5
	2	(N)ER020LD	15/5	2.4/0.8	9.1/5.7	4.6/2.9	10.0 x 1	4	168	1.5
	2	(N)ER020SD	29/10	4.7/1.6	19.6/9.4	9.8/4.7	10.0 x 1	5	284	1.5
	2 1/2	(N)ER025SD	23/8	4.7/1.6	19.6/9.4	9.8/4.7	11.2 x 1	4	295	1.9
	3	(N)ER030LD	17/6	4.7/1.6	19.6/9.4	9.8/4.7	12.5 x 1	4	300	2.3
	3	(N)ER030SD	23/8	6.1/2.0	24.1/10.6	12.1/5.3	12.5 x 1	4	320	2.3
5	(N)ER050LD	12/4	4.7/1.6	19.6/9.4	9.8/4.7	11.2 x 2	4	355	4.0	

## 2.2 Dimensions

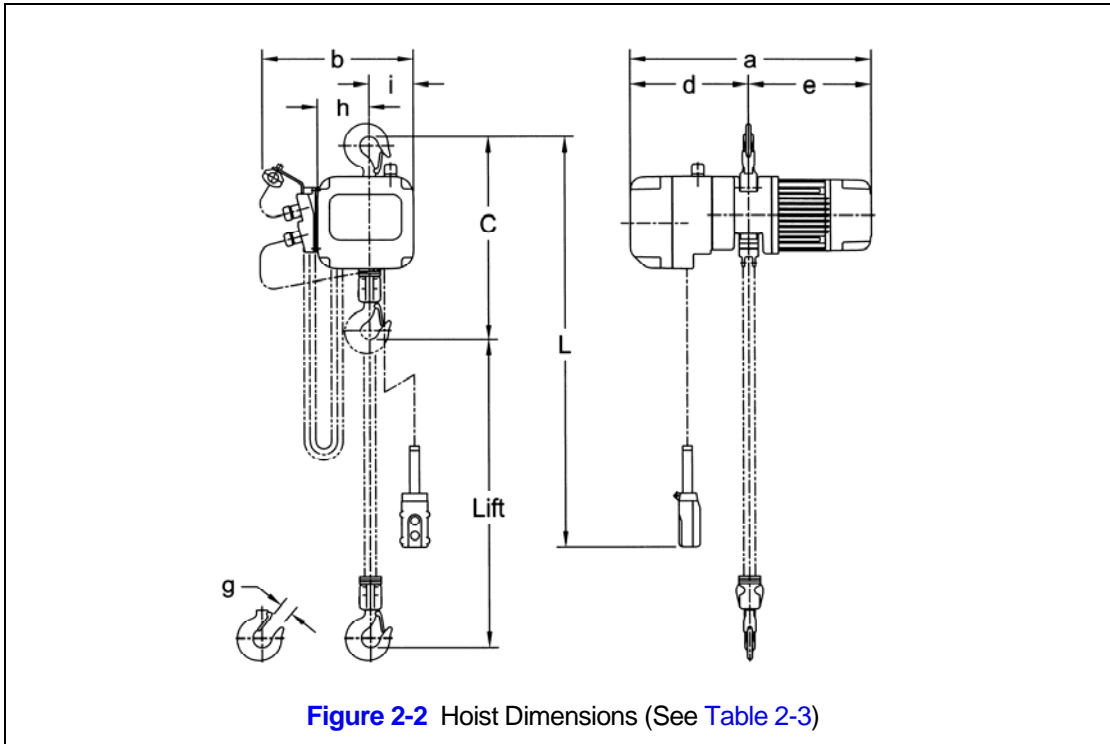

**Table 2-2** Hook Dimension\*

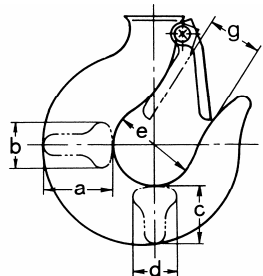

T = Top Hook  
B = Bottom Hook  
Units = inch

Capacity Code	Hook	a	b	c	d	e	g
001H, 003S, 003H, 005L, 005S	T	1.1	0.7	0.9	0.7	1.4	1.1
	B	1.1	0.7	0.9	0.7	1.4	0.9
010L, 010M, 010S	T & B	1.4	0.9	1.2	0.9	1.7	1.2
015S	T	1.9	1.1	1.6	1.1	2.0	1.5
	B	1.7	1.0	1.4	1.0	1.9	1.3
020S, 020M, 020L	T & B	1.9	1.1	1.6	1.1	2.0	1.5
025S	T	2.2	1.4	1.9	1.4	2.4	1.7
	B	2.0	1.2	1.7	1.2	2.1	1.6
030C, 030L, 030S	T & B	2.2	1.4	1.9	1.4	2.4	1.7
050L	T & B	2.6	1.7	2.2	1.7	2.5	1.8

\*Refer to [Section 5.7](#) for inspection dimensions and limits.

**Table 2-3 Hoist Dimensions**

Hoist Code	Minimum Headroom: C (in)	L* (ft)	a (in)	b (in)	d (in)	e (in)	g (in)	h (in)	i (in)	
<b>SINGLE SPEED</b>	(N)ER001H	13.8	7.2	21.1	13.0	10.4	10.7	0.9	4.0	3.9
	(N)ER003S	13.8	7.2	21.1	13.0	10.4	10.7	0.9	4.0	3.9
	(N)ER003H	14.6	7.2	21.9	13.8	10.8	11.1	0.9	4.7	4.1
	(N)ER005L	14.0	7.2	21.1	13.0	10.4	10.7	0.9	4.0	3.9
	(N)ER005S	14.6	7.2	21.9	13.8	10.8	11.1	0.9	4.7	4.1
	(N)ER010L	16.1	7.2	21.9	13.8	10.8	11.1	1.2	4.7	4.1
	NER010M	16.1	7.2	23.2	13.8	10.6	12.6	1.2	4.7	4.1
	(N)ER010S	17.3	7.2	25.6	16.5	12.6	13.0	1.2	6.1	5.2
	(N)ER015S	19.9	7.2	25.6	16.5	12.6	13.0	1.3	6.1	5.2
	(N)ER020L	22.0	7.2	25.6	16.5	12.6	13.0	1.5	6.1	5.2
	NER020M	22.0	7.2	26.9	16.5	12.4	14.4	1.5	6.1	5.2
	(N)ER020S	24.0	8.2	30.9	18.9	15.5	15.5	1.5	7.2	6.5
	(N)ER025S	24.6	8.2	30.9	18.9	15.5	15.5	1.6	7.2	6.5
	NER030C	29.5	8.2	26.9	16.5	12.4	14.4	1.7	8.2	3.0
	(N)ER030L	26.0	8.2	30.9	18.9	15.5	15.5	1.7	7.2	6.5
	(N)ER030S	26.0	8.2	30.9	18.9	15.5	15.5	1.7	7.2	6.5
(N)ER050L	32.9	8.2	30.9	18.9	15.5	15.5	1.8	9.6	4.0	
<b>DUAL SPEED</b>	(N)ER001HD	13.8	7.2	22.2	13.0	10.4	11.9	0.9	4.0	3.9
	(N)ER003SD	13.8	7.2	22.2	13.0	10.4	11.9	0.9	4.0	3.9
	(N)ER003HD	14.6	7.2	23.2	13.8	10.6	12.6	0.9	4.7	4.1
	(N)ER005LD	14.0	7.2	22.2	13.0	10.4	11.9	0.9	4.0	3.9
	(N)ER005SD	14.6	7.2	23.2	13.8	10.6	12.6	0.9	4.7	4.1
	(N)ER010LD	16.3	7.2	23.2	13.8	10.6	12.6	1.2	4.7	4.1
	(N)ER010SD	17.3	7.2	26.9	16.5	12.4	14.4	1.2	6.1	5.2
	(N)ER015SD	20.5	7.2	26.9	16.5	12.4	14.4	1.3	6.1	5.2
	(N)ER020LD	22.6	7.2	26.9	16.5	12.4	14.4	1.5	6.1	5.2
	(N)ER020SD	27.0	8.2	32.2	18.9	15.5	16.8	1.5	7.2	6.5
	(N)ER025SD	27.0	8.2	32.2	18.9	15.5	16.8	1.6	7.2	6.5
	(N)ER030LD	28.5	8.2	32.2	18.9	15.5	16.8	1.7	7.2	6.5
	(N)ER030SD	28.5	8.2	32.2	18.9	15.5	16.8	1.7	7.2	6.5
(N)ER050LD	35.2	8.2	32.2	18.9	15.5	16.8	1.8	9.6	4.0	

\*The "L" dimensions are based on the standard lift of 10 feet.

## 2.3 Hot Metal Applications

2.3.1 Requirements for Hot Metal Applications are based on specification ASTM-E-2349 and ASME B30.16. Refer to EDOC0352 for details.

## 3.0 Preoperational Procedures

### 3.1 Fill Gear Box with Oil

- 3.1.1 **⚠ CAUTION** The ER (with mechanical load brake/friction clutch) uses different gear oil than the NER (with friction clutch). DO NOT use any oil or quantity other than that listed below.
- 3.1.2 For a new hoist the correct quantity and type of oil is supplied with the hoist in separate container(s). Remove the fill plug from the top of the hoist and connect the flexible pour tube to the oil container. Pour in all of the oil from the separate container(s), then replace the fill plug.
- 3.1.3 Refer to [Section 6.2](#) when replacing the gear oil or checking the gear oil level.

Capacity Code	quarts	liters
001H, 003S, 005L	0.74	0.7
003H, 005S, 010L, 010M	1.06	1.0
010S, 015S, 020L, 020M, 030C	1.80	1.7
020S, 025S, 030L, 030S, 050L	3.17	3.0

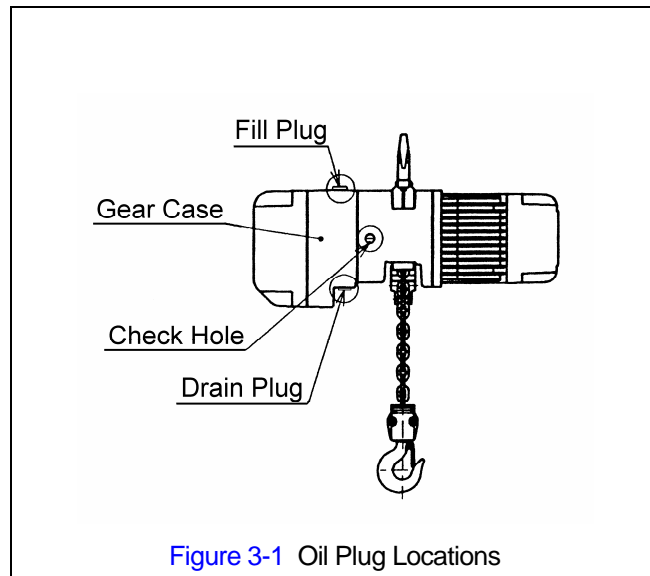

#### NER Gear Oil:

- Harrington standard: Bonnoc M260 (NIPPON OIL)
- Acceptable equivalent: Meropa 320 (TEXACO)
- Acceptable equivalent: Meropa 320 (CALTEX)

#### ER Gear Oil:

- Harrington standard: Antoil super B (NIPPON OIL)
- Acceptable equivalent: Meropa No.68 (TEXACO)

### 3.2 Chain

- 3.2.1 The quantity and location of the chain components including cushion rubbers, chain springs and striker plates depend on the hoist model, capacity and limits switches. Never operate the hoist with incorrect, missing or damaged chain components. Refer to the hoist's nameplate, [Table 3-2](#), and [Figures 3-2, 3-3, and 3-4](#) and ensure that all chain components are in the correct location and properly installed.
- 3.2.2 When the hoist is used without a chain container, the free end of the chain is attached to the hoist body as shown in [Figure 3-4](#). Connect the no load end of the chain to Chain Guide A with the End Wire or End Suspender provided. For 5 ton hoist, connect the no load end of the chain directly to Chain Guide A if Chain Guide A is notched to accept the chain. Make sure the chain remains free of twists and the chain Stopper is installed on the correct link. Refer to [Table 3-2](#) for proper placement of Stopper.

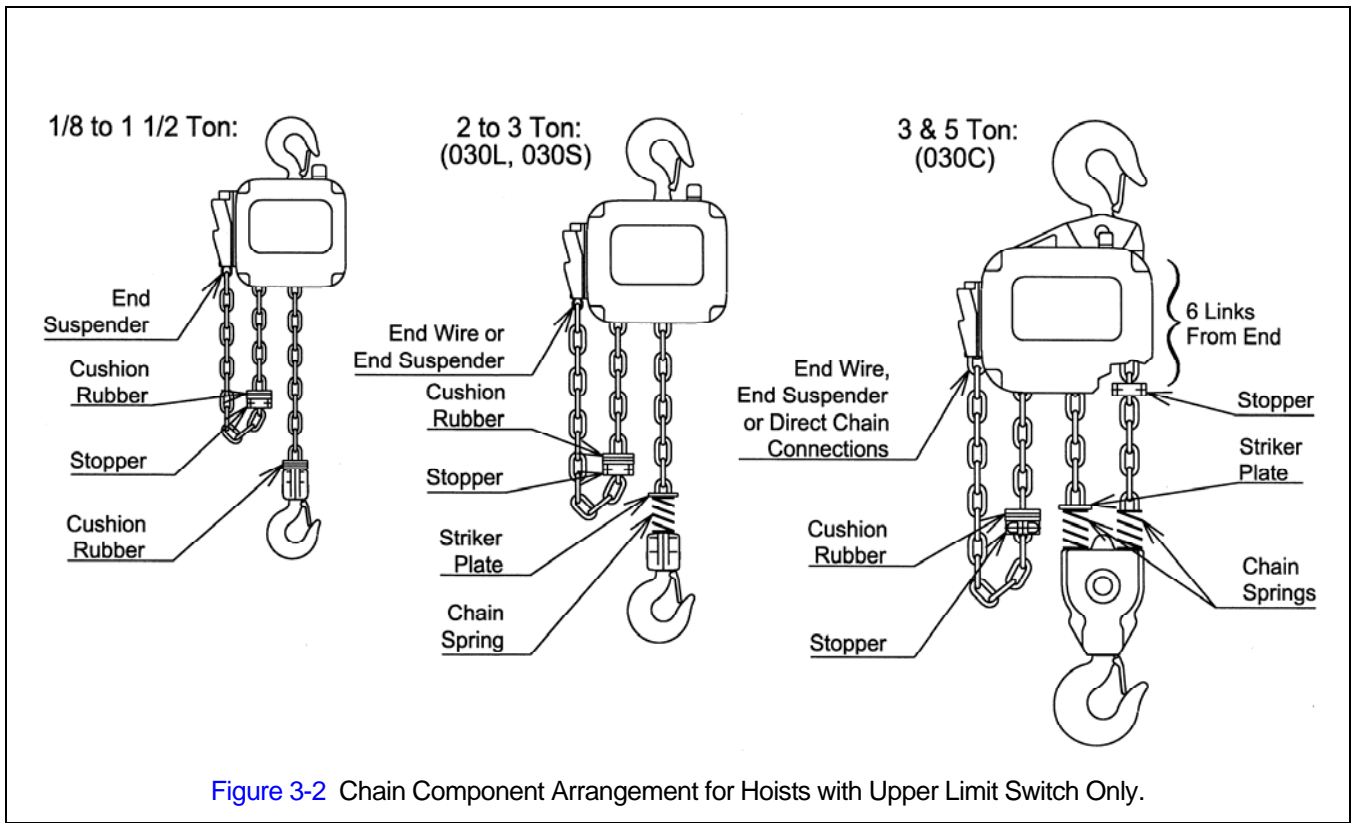

Figure 3-2 Chain Component Arrangement for Hoists with Upper Limit Switch Only.

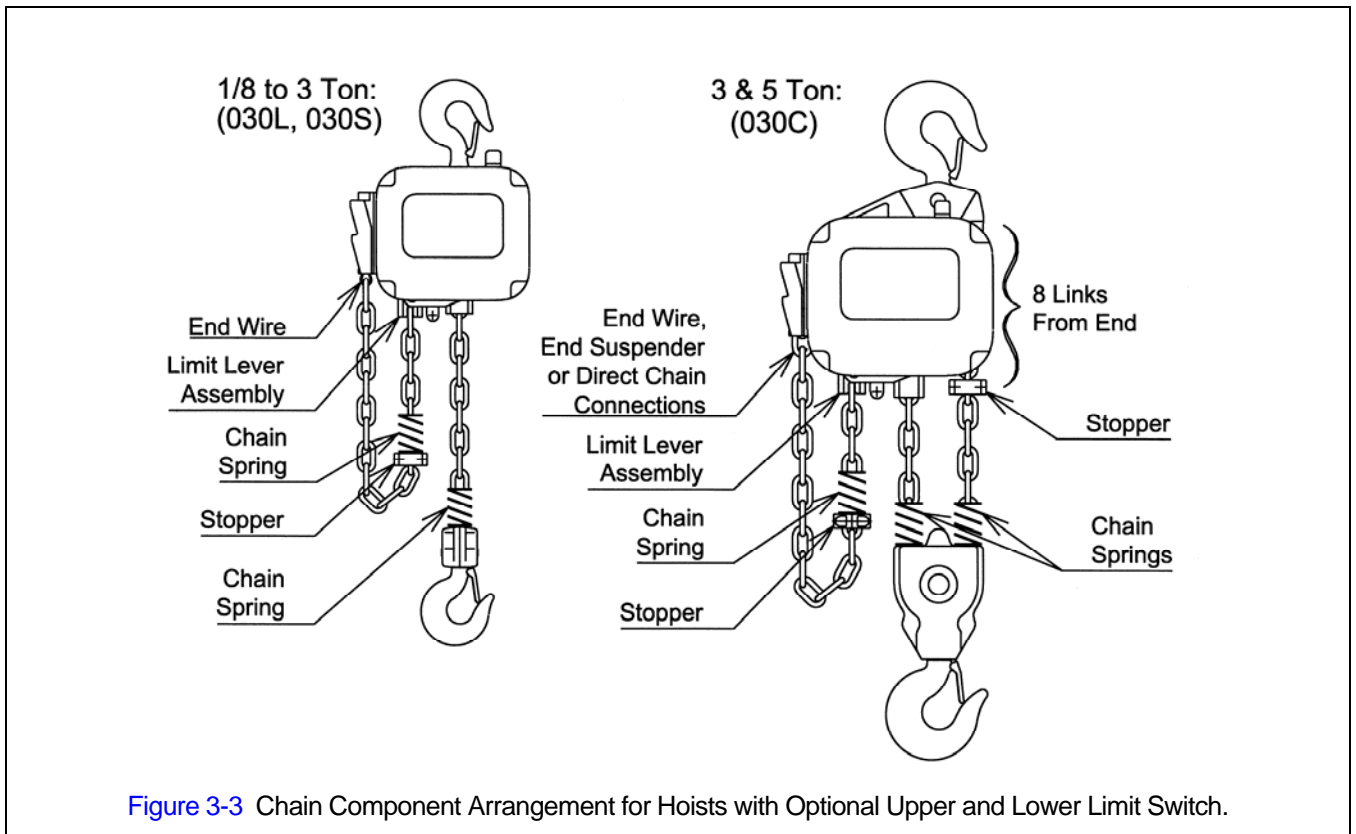
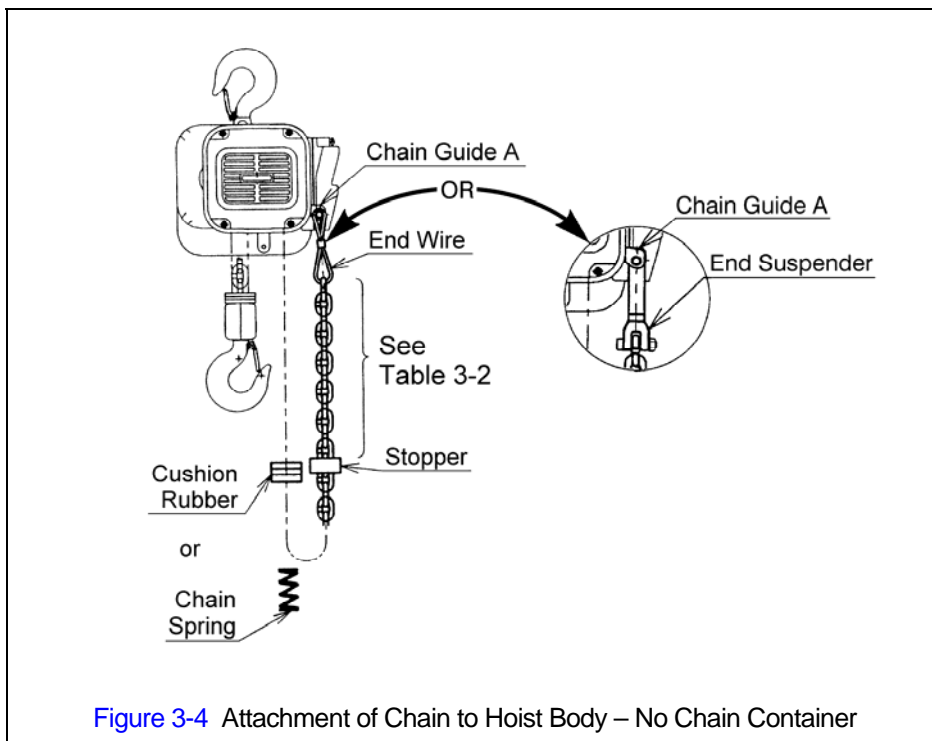

Figure 3-3 Chain Component Arrangement for Hoists with Optional Upper and Lower Limit Switch.

Table 3-2 Chain Stopper Placement		
Capacity Code	Without Chain Container	With Chain Container
001HD, dual speed with optional upper/lower limit switch	25 <sup>th</sup> link from the free end	3 <sup>rd</sup> link from the free end
001H, 003S, 003H, 005L, 005S, 010L, 010M, 010S, 015S, 020L, 020M, 030C	15 <sup>th</sup> link from the free end	3 <sup>rd</sup> link from the free end
020S, 025S, 030L, 030S, 050L	13 <sup>th</sup> link from the free end	3 <sup>rd</sup> link from the free end



3.2.3 When the optional canvas chain container is used, unfold it fully and install it on the hoist body as shown in Figure 3-5. In this case the free end of the chain is not attached to the hoist body and the chain stopper is installed on the third link from the free end. To place the chain into the chain container, feed the chain into the chain container beginning with the free end. Take care to avoid twisting or tangling the chain. NEVER put all the chain into the container at once. Lumped or twisted chain may:

- Upper Limit Switch Only - jam against the hoist body activating the friction clutch and potentially damaging the chain.
- Upper and Lower Limit Switch (Optional) - activate the down limit switch and stop the hoist during lowering.

3.2.4 **CAUTION** Each chain container indicates the maximum length of the load chain that can be stored in the container. The amount of chain the container must hold is equal to the lift on the hoist. DO NOT use a chain container with a storage capacity less than the lift length on the hoist. If all of the chain can not be stored in the container, the limit switch will not operate properly.

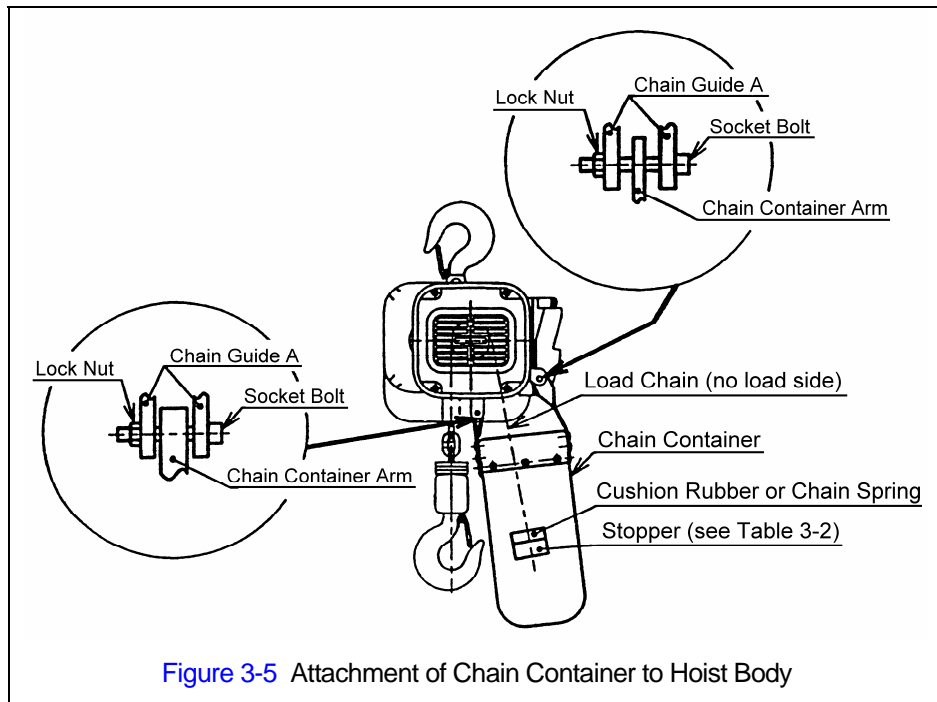

Figure 3-5 Attachment of Chain Container to Hoist Body

- 3.2.5 When using an optional steel chain container, refer to the assembly drawing and instructions provided with the container for correct assembly and attachment.
- 3.2.6 **⚠ WARNING** Verify that the load chain is not twisted or tangled prior to operating the hoist. Make sure the bottom hook on 3 and 5 Ton double fall models is not capsized. See Figures 3-6 and 3-7. Correct all chain irregularities before conducting the first hoist operation.

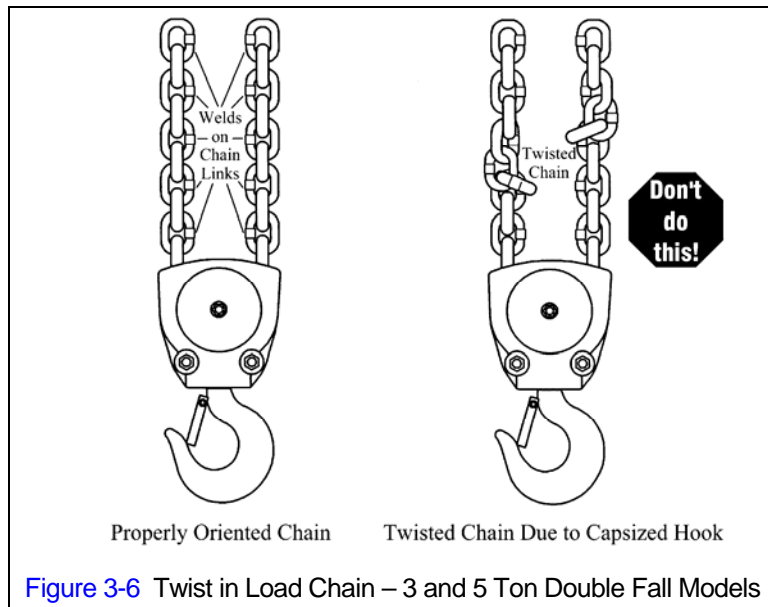
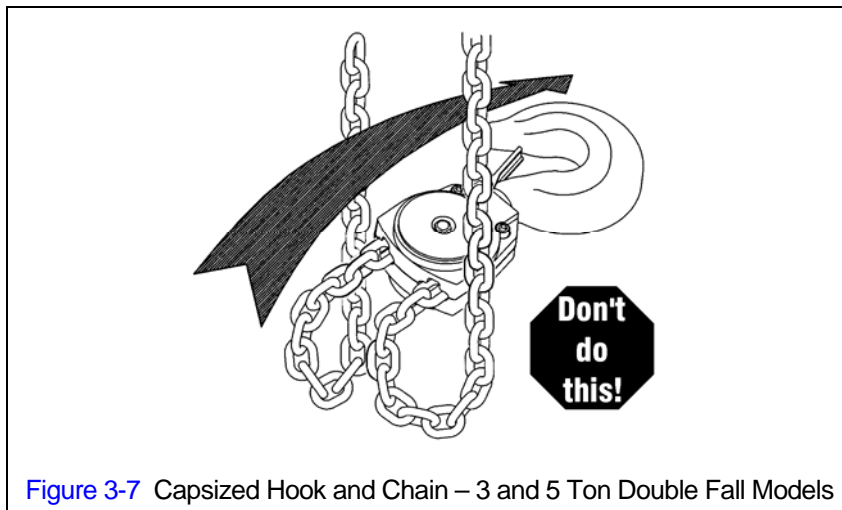

Figure 3-6 Twist in Load Chain – 3 and 5 Ton Double Fall Models



### 3.3 Mounting Location

- 3.3.1 **⚠ WARNING** Prior to mounting the hoist ensure that the suspension and the supporting structure are adequate to support the hoist and its loads. If necessary consult a professional that is qualified to evaluate the adequacy of the suspension location and its supporting structure.
- 3.3.2 **NOTICE** See [Section 6.7](#) for outdoor installation considerations.

### 3.4 Mounting the Hoist

- 3.4.1 Manual Trolley - Follow instructions in Owner's Manual provided with the trolley.
- 3.4.2 Motorized Trolley - Follow instructions in Owner's Manual provided with the trolley.
- 3.4.3 Hook Mounted to a Fixed Location - Attach the hoist's top hook to the fixed suspension point.
- 3.4.4 **⚠ WARNING** Ensure that the fixed suspension point rests on the center of the hook's saddle and that the hook's latch is engaged.

### 3.5 Electrical Connections

- 3.5.1 **⚠ CAUTION** Ensure that the voltage of the electric power supply is proper for the hoist or trolley.
- 3.5.2 **⚠ CAUTION** Do not apply variable speed control to the NER model hoist. Use the ER model for applications of variable speed control for hoists.
- 3.5.3 **⚠ DANGER** Before proceeding, ensure that the electrical supply for the hoist or trolley has been de-energized (disconnected). Lock out and tag out in accordance with ANSI Z244.1 "Personnel Protection -Lockout/Tagout of Energy Sources".
- 3.5.4 This instruction applies to installations where the hoist is installed hook mounted to a fixed suspension point or installed on a manual trolley. In this case the hoist is controlled by a pendant with two push buttons – one for raising and one for lowering. Refer to the appropriate trolley Owner's Manual if the hoist is installed on a motorized trolley.

#### Pendant Cord

The Pendant Cord connects to the hoist via a 5-pin (5P) Plug and Socket. Make this connection as follows:

- Refer to [Figure 3-8](#).
- Insert the 5P Plug into the 5P Socket on the hoist and hand tighten the Screw Coupling.
- Install the Cord Strain Relief Cable to the Cord Support on the bottom of the hoist.

### Power Supply Cable - Hoist Connection

The Power Supply Cable connects to the hoist via a 4-pin (4P) plug and socket. Make this connection as follows:

- Refer to [Figure 3-8](#).
- Insert the 4P plug of the Power Supply Cable into the 4P Socket on the hoist and hand tighten the screw coupling.
- Install the Cable Support Arm (pre-installed on the Power Supply Cable) on to the Socket Holder using the pre-installed Machine Screws and Lock Washers.
- Use care to avoid twisting or kinking the Power Supply Cable.

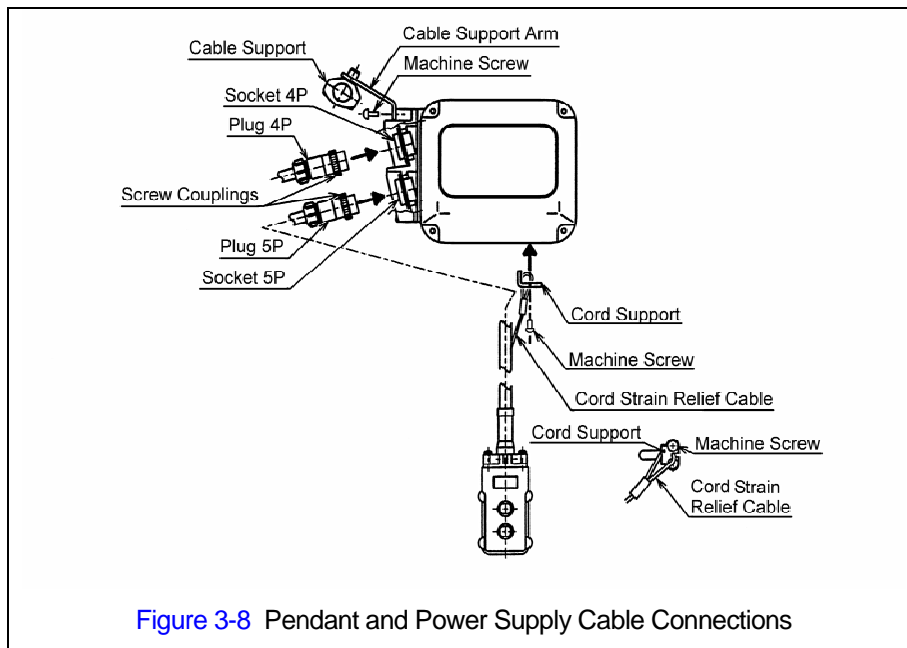

Figure 3-8 Pendant and Power Supply Cable Connections

### Power Supply Cable - Installation

If the hoist is hook mounted to a fixed support ensure that the Power Supply Cable is properly installed and supported between the hoist and the electrical power supply.

If the hoist is installed on a manual trolley, then the Power Supply Cable must be installed along the beam that the trolley runs on. For curved beams a special cable suspension system will be needed, and this instruction does not apply. For straight beams install the Power Supply Cable as follows:

- Install a guide wire system parallel to the beam.
- For a manual trolley the guide wire should be positioned slightly outside the hoist's Cable Support as shown in [Figure 3-8](#).
- Use the Cable Trolleys supplied with the hoist to suspend the Power Supply Cable from the guide wire. Space the Cable Trolleys every 5 feet.

- 3.5.5 Connection to Electrical Power Source - The red, white, and black wires of the Power Supply Cable should be connected to an Electric Power Disconnect Switch or Circuit Breaker. This connection should be made so that the hoist is phased properly. Refer to [Section 3.6.11](#) for instructions on how to check for correct power supply phase connection.
- 3.5.6 Fuse/Breaker Capacity -The hoist's power supply should be equipped with overcurrent protection such as fuses, which should be selected for 110% to 120% of total listed full load amperage, and should be dual element time-delay fuses. Refer to the motor nameplate for the full load amperage draw.

- 3.5.7 **⚠ DANGER** Grounding - An improper or insufficient ground connection creates an electrical shock hazard when touching any part of the hoist or trolley. In the Power Supply Cable the ground wire will be either Green with Yellow stripe or solid Green. It should always be connected to a suitable ground connection. Do not paint the trolley wheel running surfaces of the beam as this can affect grounding.

## 3.6 Preoperational Checks and Trial Operation

- 3.6.1 **⚠ WARNING** Confirm the adequacy of the rated capacity for all slings, chains, wire ropes and all other lifting attachments before use. Inspect all load suspension members for damage prior to use and replace or repair all damaged parts.
- 3.6.2 **⚠ WARNING** Verify and correct all chain irregularities prior to operating the hoist. Refer to [Section 3.2](#).
- 3.6.3 Measure and record the “k” dimension of all hooks on hoist. See [Table 5-4](#) under [Section 5](#), “Inspection”.
- 3.6.4 Record the hoist’s Code, Lot and Serial Number (from the name plate on the hoist; see section 10) in the space provided on the cover of this manual.
- 3.6.5 Ensure that the hoist is properly installed to either a fixed point, or trolley, whichever applies.
- 3.6.6 If hoist is installed on a trolley, ensure that
- trolley is properly installed on the beam, and
  - stops for the trolley are correctly positioned and securely installed on the beam.
- 3.6.7 Ensure that all nuts, bolts and split pins (cotter pins) are sufficiently fastened.
- 3.6.8 Pull down on the Pendant and ensure that the Cord Strain Relief Cable takes the force, not the Pendant Cord.
- 3.6.9 **⚠ CAUTION** Check supply voltage before everyday use. If the voltage varies more than 10% of the rated value, electrical devices may not function normally.
- 3.6.10 Confirm proper operation.
- Before operating read and become familiar with [Section 4 - Operation](#).
  - Before operating ensure that the hoist (and trolley) meets the Inspection, Testing and Maintenance requirements of ANSI/ASME B30.16.
  - Before operating ensure that nothing will interfere with the full range of the hoist’s (and trolley’s) operation.
- 3.6.11 **⚠ WARNING** The hoist must be connected to the power source such that its direction of operation corresponds to the up-and-down commands issued from the pendant control; i.e. pushing the up button must cause the hoist to raise. If the hoist does not operate correctly, shut off and lockout /tagout the main power source to the hoist. Disconnect and switch any two of the three input power leads at the power source to correct the hoist’s motor phasing.

## 4.0 Operation

### 4.1 Introduction

#### **DANGER**

DO **NOT** WALK UNDER A SUSPENDED LOAD

#### **WARNING**

HOIST OPERATORS SHALL BE REQUIRED TO READ THE OPERATION SECTION OF THIS MANUAL, THE WARNINGS CONTAINED IN THIS MANUAL, INSTRUCTION AND WARNING LABELS ON THE HOIST OR LIFTING SYSTEM, AND THE OPERATION SECTIONS OF ANSI/ASME B30.16 and ANSI/ASME B30.10. THE OPERATOR SHALL ALSO BE REQUIRED TO BE FAMILIAR WITH THE HOIST AND HOIST CONTROLS BEFORE BEING AUTHORIZED TO OPERATE THE HOIST OR LIFTING SYSTEM.

HOIST OPERATORS SHOULD BE TRAINED IN PROPER RIGGING PROCEDURES FOR THE ATTACHMENT OF LOADS TO THE HOIST HOOK.

HOIST OPERATORS SHOULD BE TRAINED TO BE AWARE OF POTENTIAL MALFUNCTIONS OF THE EQUIPMENT THAT REQUIRE ADJUSTMENT OR REPAIR, AND TO BE INSTRUCTED TO STOP OPERATION IF SUCH MALFUNCTIONS OCCUR, AND TO IMMEDIATELY ADVISE THEIR SUPERVISOR SO CORRECTIVE ACTION CAN BE TAKEN.

HOIST OPERATORS SHOULD HAVE NORMAL DEPTH PERCEPTION, FIELD OF VISION, REACTION TIME, MANUAL DEXTERITY, AND COORDINATION.

HOIST OPERATORS SHOULD **NOT** HAVE A HISTORY OF OR BE PRONE TO SEIZURES, LOSS OF PHYSICAL CONTROL, PHYSICAL DEFECTS, OR EMOTIONAL INSTABILITY THAT COULD RESULT IN ACTIONS OF THE OPERATOR BEING A HAZARD TO THE OPERATOR OR TO OTHERS.

HOIST OPERATORS SHOULD **NOT** OPERATE A HOIST OR LIFTING SYSTEM WHEN UNDER THE INFLUENCE OF ALCOHOL, DRUGS, OR MEDICATION.

OVERHEAD HOISTS ARE INTENDED ONLY FOR VERTICAL LIFTING SERVICE OF FREELY SUSPENDED UNGUIDED LOADS. DO **NOT** USE HOIST FOR LOADS THAT ARE NOT LIFTED VERTICALLY, LOADS THAT ARE NOT FREELY SUSPENDED, OR LOADS THAT ARE GUIDED.

#### **NOTICE**

- Read ANSI/ASME B30.16 and ANSI/ASME B30.10.
- Read the hoist manufacturer's Operating and Maintenance Instructions.
- Read all labels attached to equipment.

The operation of an overhead hoist involves more than activating the hoist's controls. Per the ANSI/ASME B30 standards, the use of an overhead hoist is subject to certain hazards that cannot be mitigated by engineered features, but only by the exercise of intelligence, care, common sense, and experience in anticipating the effects and results of activating the hoist's controls. Use this guidance in conjunction with other warnings, cautions, and notices in this manual to govern the operation and use of your overhead hoist.

## 4.2 Shall's and Shall Not's for Operation

### **WARNING**

Improper operation of a hoist can create a potentially hazardous situation which, if not avoided, could result in death or serious injury, and substantial property damage. To avoid such a potentially hazardous situation **THE OPERATOR SHALL:**

- **NOT** lift more than rated load for the hoist.
- **NOT** operate unless load is centered under hoist.
- **NOT** use damaged hoist or hoist that is not working properly.
- **NOT** use hoist with twisted, kinked, damaged, or worn chain.
- **NOT** use hoist if the bottom hook is capsized (double fall hoists - see [Section 3.2](#)).
- **NOT** use the hoist to lift, support, or transport people.
- **NOT** lift loads over people.
- **NOT** apply load unless load chain is properly seated in the load sheave (and idle sheave for hoist with two chain falls).
- **NOT** use the hoist in such a way that could result in shock or impact loads being applied to the hoist.
- **NOT** attempt to lengthen the load chain or repair damaged load chain.
- **NOT** operate hoist when it is restricted from forming a straight line from hook to hook in the direction of loading.
- **NOT** use load chain as a sling or wrap load chain around load.
- **NOT** apply the load to the tip of the hook or to the hook latch.
- **NOT** apply load if binding prevents equal loading on all load-supporting chains.
- **NOT** operate beyond the limits of the load chain travel.
- **NOT** operate hoist with missing/damaged chain springs, cushion rubbers, stoppers or striker plates.
- **NOT** leave load supported by the hoist unattended unless specific precautions have been taken.
- **NOT** allow the chain, or hook to be used as an electrical or welding ground.
- **NOT** allow the chain, or hook to be touched by a live welding electrode.
- **NOT** remove or obscure the warnings on the hoist.
- **NOT** operate a hoist on which the safety placards or decals are missing or illegible.
- Be familiar with operating controls, procedures, and warnings.
- Make sure the unit is securely attached to a suitable support before applying load.
- Make sure load slings or other approved single attachments are properly sized, rigged, and seated in the hook saddle.
- Take up slack carefully - make sure load is balanced and load-holding action is secure before continuing.
- Make sure all persons stay clear of the supported load.
- Protect the hoist's load chain from weld splatter or other damaging contaminants.
- Report malfunctions or unusual performances (including unusual noises) of the hoist and remove the hoist from service until the malfunction or unusual performance is resolved.
- Make sure hoist limit switches function properly.
- Warn personnel before lifting or moving a load.
- Warn personnel of an approaching load.

## **⚠ CAUTION**

Improper operation of a hoist can create a potentially hazardous situation which, if not avoided, could result in minor or moderate injury, or property damage. To avoid such a potentially hazardous situation **THE OPERATOR SHALL:**

- Maintain a firm footing or be otherwise secured when operating the hoist.
- Check brake function by tensioning the hoist prior to each lift operation.
- Use hook latches. Latches are to retain slings, chains, etc. under slack conditions only.
- Make sure the hook latches are closed and not supporting any parts of the load.
- Make sure the load is free to move and will clear all obstructions.
- Avoid swinging the load or hook.
- Make sure hook travel is in the same direction as shown on controls.
- Inspect the hoist regularly, replace damaged or worn parts, and keep appropriate records of maintenance.
- Use the hoist manufacturer's recommended parts when repairing the unit.
- Lubricate load chain per hoist manufacturer's recommendations.
- **NOT** use the hoist load limiting or warning device to measure load.
- **NOT** use limit switches as routine operating stops. They are emergency devices only.
- **NOT** allow your attention to be diverted from operating the hoist.
- **NOT** allow the hoist to be subjected to sharp contact with other hoists, structures, or objects through misuse.
- **NOT** adjust or repair the hoist unless qualified to perform such adjustments or repairs.

### 4.3 Hoist Controls

- 4.3.1 For hoists mounted to motorized trolleys follow the control instruction included in the trolley's Owner's Manual.
- 4.3.2 Single Speed Pendant Control – When using the pendant control depress the up button to raise the hoist or the down button to lower the hoist as shown in [Figure 4-1](#) below. To stop motion release the buttons.
- 4.3.3 Dual Speed Pendant Control – Pendant controls supplied with dual speed hoists have two step control buttons. For low speed depress the button to the first step and for high speed depress the button fully to the second step. Use the up button to raise the hoist or the down button to lower the hoist as shown in [Figure 4-1](#) below. To stop motion release the buttons.
- 4.3.4 **⚠ CAUTION** Make sure the motor completely stops before reversing direction.

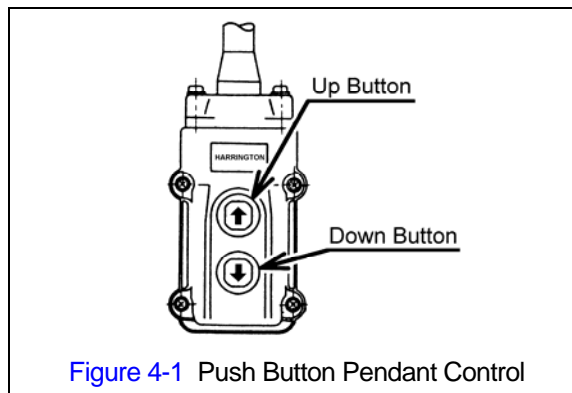

## 5.0 Inspection

### 5.1 General

- 5.1.1 The inspection procedure herein is based on ANSI/ASME B30.16. The following definitions are from ANSI/ASME B30.16 and pertain to the inspection procedure below.
- **Designated Person** – a person selected or assigned as being competent to perform the specific duties to which he/she is assigned.
  - **Qualified Person** – a person who, by possession of a recognized degree or certificate of professional standing, or who, by extensive knowledge, training, and experience, has successfully demonstrated the ability to solve or resolve problems relating to the subject matter and work.
  - **Normal Service** – that distributed service which involves operation with randomly distributed loads within the rated load limit, or uniform loads less than 65% of rated load for not more than 25% of the time.
  - **Heavy Service** – that service which involves operation within the rated load limit which exceeds normal service.
  - **Severe Service** – that service which involves normal or heavy service with abnormal operating conditions.

### 5.2 Inspection Classification

- 5.2.1 Initial Inspection – prior to initial use, all new, altered, or modified hoists shall be inspected by a designated person to ensure compliance with the applicable provisions of this manual.
- 5.2.2 Inspection Classification – the inspection procedure for hoists in regular service is divided into two general classifications based upon the intervals at which inspection should be performed. The intervals in turn are dependent upon the nature of the critical components of the hoist and the degree of their exposure to wear, deterioration, or malfunction. The two general classifications are herein designated as FREQUENT and PERIODIC, with respective intervals between inspections as defined below.
- 5.2.3 FREQUENT Inspection – visual examinations by the operator or other designated personnel with intervals per the following criteria:
- Normal service – monthly
  - Heavy service – weekly to monthly
  - Severe service – daily to weekly
  - Special or infrequent service – as recommended by a qualified person before and after each occurrence.
- 5.2.4 PERIODIC Inspection – visual inspection by a designated person with intervals per the following criteria:
- Normal service – yearly
  - Heavy service – semiannually
  - Severe service – quarterly
  - Special or infrequent service – as recommended by a qualified person before the first such occurrence and as directed by the qualified person for any subsequent occurrences.

### 5.3 Frequent Inspection

- 5.3.1 Inspections should be made on a FREQUENT basis in accordance with [Table 5-1](#), “Frequent Inspection.” Included in these FREQUENT Inspections are observations made during operation for any defects or damage that might appear between Periodic Inspections. Evaluation and resolution of the results of FREQUENT Inspections shall be made by a designated person such that the hoist is maintained in safe working condition.

<b>Table 5-1 Frequent Inspection</b>
All functional operating mechanisms for maladjustment and unusual sounds.
Operation of limit switch and associated components
Hoist braking system for proper operation
Hooks in accordance with ANSI/ASME B30.10
Hook latch operation
Load chain in accordance with <a href="#">Section 5.7</a>
Load chain reeving for compliance with <a href="#">Section 3.2 and 6.4</a>

### 5.4 Periodic Inspection

- 5.4.1 Inspections should be made on a PERIODIC basis in accordance with [Table 5-2](#), “Periodic Inspection.” Evaluation and resolution of the results of PERIODIC Inspections shall be made by a designated person such that the hoist is maintained in safe working condition.
- 5.4.2 For inspections where load suspension parts of the hoist are disassembled, a load test per ANSI/ASME B30.16 must be performed on the hoist after it is re-assembled and prior to its return to service.

<b>Table 5-2 Periodic Inspection</b>
Requirements of frequent inspection.
Evidence of loose bolts, nuts, or rivets.
Evidence of worn, corroded, cracked, or distorted parts such as load blocks, suspension housing, chain attachments, clevises, yokes, suspension bolts, shafts, gears, bearings, pins and rollers.
Evidence of damage to hook retaining nuts or collars and pins, and welds or rivets used to secure the retaining members.
Evidence of damage or excessive wear of load and idler sheaves.
Evidence of excessive wear on motor or load brake.
Electrical apparatus for signs of pitting or any deterioration of visible controller contacts.
Evidence of damage of supporting structure or trolley, if used.
Function labels on pendant control stations for legibility.
Warning label properly attached to the hoist and legible (see <a href="#">Section 1.2</a> ).
End connections of load chain.

## 5.5 Occasionally Used Hoists

- 5.5.1 Hoists that are used infrequently shall be inspected as follows prior to placing in service:
- Hoist Idle More Than 1 Month, Less Than 1 Year: Inspect per FREQUENT Inspection criteria in [Section 5.3](#).
  - Hoist Idle More Than 1 Year: Inspect per PERIODIC Inspection criteria in [Section 5.4](#).

## 5.6 Inspection Records

- 5.6.1 Dated inspection reports and records should be maintained at time intervals corresponding to those that apply for the hoist's PERIODIC interval per [Section 5.2.4](#). These records should be stored where they are available to personnel involved with the inspection, maintenance, or operation of the hoist.
- 5.6.2 A long range chain inspection program should be established and should include records of examination of chains removed from service so a relationship can be established between visual observation and actual condition of the chain.

## 5.7 Inspection Methods and Criteria

- 5.7.1 This section covers the inspection of specific items. The list of items in this section is based on those listed in ANSI/ASME B30.16 for the Frequent and Periodic Inspection. In accordance with ANSI/ASME B30.16, these inspections are not intended to involve disassembly of the hoist. Rather, disassembly for further inspection would be required if frequent or periodic inspection results so indicate. Such disassembly and further inspection should only be performed by a qualified person trained in the disassembly and re-assembly of the hoist.

**Table 5-3 Hoist Inspection Methods and Criteria**

Item	Method	Criteria	Action
Functional operating mechanisms.	Visual, Auditory	Mechanisms should be properly adjusted and should not produce unusual sounds when operated.	Repair or replace as required.
Limit Switch	Function	Proper operation. Actuation of limit switch should stop hoist.	Repair or replace as required.
Limit Lever Assembly	Visual, Function	Lever should not be bent or significantly worn and should be able to move freely.	Replace.
Braking System Operation	Function	Braking distance with rated capacity should not exceed 3% of the lifting speed (approximately two chain links).	Repair or replace as required.
Hooks - Surface Condition	Visual	Should be free of significant rust, weld splatter, deep nicks, or gouges.	Replace.
Hooks - Fretting wear	Measure	The "u" and "t" dimensions should not be less than discard value listed in <a href="#">Table 5-4</a>	Replace.
Hooks - Stretch	Measure	The "k" dimension should not be greater than 1.15 times that measured and recorded at the time of purchase (See <a href="#">Section 3.6</a> ). If recorded "k" values are not available for hooks when new, use nominal "k" values from <a href="#">Table 5-4</a> .	Replace.
Hooks - Bent Shank or Neck	Visual	Shank and neck portions of hook should be free of deformations.	Replace.

**Table 5-3 Hoist Inspection Methods and Criteria**

Item	Method	Criteria	Action
Hooks - Yoke Assembly	Visual	Should be free of significant rust, weld splatter, nicks, gouges. Holes should not be elongated, fasteners should not be loose, and there should be no gap between mating parts.	Tighten or replace as required.
Hooks - Swivel Bearing	Visual, Function	Bearing parts and surfaces should not show significant wear, and should be free of dirt, grime and deformations. Hook should rotate freely with no roughness.	Clean/lubricate, or replace as required.
Hooks - Idle Sheave and Axle (Bottom Hook on Double Fall Hoist)	Visual, Function	Pockets of Idle Sheave should be free of significant wear. Idle Sheave surfaces should be free of nicks, gouges, dirt and grime. Bearing parts and surfaces of Idle Sheave and Axle should not show significant wear. Idle Sheave should rotate freely with no roughness or significant free play.	Clean/lubricate, or replace as required.
Hooks - Hook Latches	Visual, Function	Latch should not be deformed. Attachment of latch to hook should not be loose. Latch spring should not be missing and should not be weak. Latch movement should not be stiff - when depressed and released latch should snap smartly to its closed position.	Replace.
Load Chain - Surface Condition	Visual	Should be free of rust, nicks, gouges, dents and weld splatter. Links should not be deformed, and should not show signs of abrasion. Surfaces where links bear on one another should be free of significant wear.	Replace.
Load Chain - Pitch and Wire Diameter	Measure	The "P" dimension should not be greater than maximum value listed in <a href="#">Table 5-5</a> . The "d" dimension should not be less than minimum value listed in <a href="#">Table 5-5</a> .	Replace. Inspect Load Sheave (and Idle Sheave for double fall hoist).
Load Chain - Lubrication	Visual, Auditory	Entire surface of each chain link should be coated with lubricant and should be free of dirt and grime. Chain should not emit cracking noise when hoisting a load.	Clean/lubricate (see <a href="#">Section 6.0</a> ).
Load Chain - Reeving	Visual	Chain should be reeved properly through Load Sheave (and Idle Sheave for double fall hoist) - refer to <a href="#">Section 6.4</a> . Chain, Chain Springs, Cushion Rubbers, Striker Plates, and Stoppers should be installed properly - refer to <a href="#">Section 3.2</a> .	Reeve/Install chain properly.
Chain Container (optional)	Visual	Container should not be damaged. Brackets should not be deformed or missing.	Replace.
Housing and Mechanical Components	Visual, Auditory, Vibration, Function	Hoist components including load blocks, suspension housing, chain attachments, clevises, yokes, suspension bolts, shafts, gears, bearings, pins and rollers should be free of cracks, distortion, significant wear and corrosion. Evidence of same can be detected visually or via detection of unusual sounds or vibration during operation.	Replace.

**Table 5-3 Hoist Inspection Methods and Criteria**

Item	Method	Criteria	Action
Bolts, Nuts and Rivets	Visual, Check with Proper Tool	Bolts, nuts and rivets should not be loose.	Tighten or replace as required.
Motor Brake	Measure, Visual	Motor brake gap should be adjusted to the distance shown in <a href="#">Table 6-4</a> before measuring the brake wear. Brake lining dimension “A” should not be less than discard value listed in <a href="#">Table 5-6</a> . Refer to <a href="#">Section 6.3</a> for gaining access to motor brake and for adjustment and inspection procedures. Braking surfaces should be clean, free of grease/oil and should not be glazed.	Adjust, Repair or Replace as required.
Contactors Contacts	Visual	Contacts should be free of significant pitting or deterioration. On hoists equipped with Count/Hour Meter check the contactor cycles – refer to <a href="#">Section 6.1</a> .	Replace.
Load Sheave	Visual	Pockets of Load Sheave should be free of significant wear.	Replace.
Cushion Rubber	Visual	Should be free of significant deformation.	Replace.
Chain Springs	Visual	Chain springs should not be deformed or compressed.	Replace.
Pendant - Switches	Function	Depressing and releasing push-buttons should make and break contacts in switch contact block and result in corresponding electrical continuity or open circuit. Push-buttons should be interlocked either mechanically or electrically to prevent simultaneous energization of circuits for opposing motions (e.g. up and down).	Repair or replace as necessary.
Pendant - Housing	Visual	Pendant housing should be free of cracks and mating surfaces of parts should seal without gaps.	Replace.
Pendant - Wiring	Visual	Wire connections to switches in pendant should not be loose or damaged.	Tighten or repair
Pendant - Cord	Visual, Electrical Continuity	Surface of cord should be free from nicks, gouges, and abrasions. Each conductor in cord should have 100% electrical continuity even when cord is flexed back-and-forth. Pendant Cord Strain Relief Cable should absorb all of the load associated with forces applied to the pendant.	Replace.
Pendant - Labels	Visual	Labels denoting functions should be legible.	Replace.
Warning Labels	Visual	Warning Labels should be affixed to the hoist (see <a href="#">Section 1.2</a> ) and they should be legible.	Replace.
Hoist Capacity Label	Visual	The label that indicates the capacity of the hoist should be legible and securely attached to the hoist.	Replace.

**Table 5-4 Top Hook & Bottom Hook Dimensions**

"k" Measured When New:

Top: \_\_\_\_\_

Bottom: \_\_\_\_\_

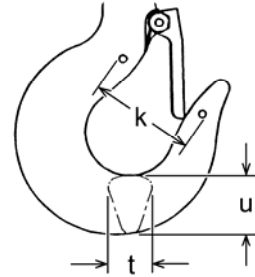

Capacity Code	Nominal "k" Dimension* inch (mm)	"u" Dimension inch (mm)		"t" Dimension inch (mm)	
		Standard	Discard	Standard	Discard
001H, 003S, 003H, 005L, 005S	1.65 (42)	0.93 (23.5)	0.83 (21)	0.69 (17.5)	0.63 (16)
010L, 010M, 010S	1.97 (50)	1.22 (31)	1.10 (28)	0.89 (22.5)	0.79 (20)
015S	2.36 (60)	1.44 (36.5)	1.30 (33)	1.04 (26.5)	0.94 (24)
020L, 020M, 020S	2.46 (62.5)	1.57 (40)	1.42 (36)	1.14 (29)	1.02 (26)
025S	2.72 (69)	43.5 (1.71)	1.54 (39)	1.24 (31.5)	1.10 (28)
030C, 030L, 030S	2.95 (75)	1.87 (47.5)	1.69 (43)	1.36 (34.5)	1.22 (31)
050L	3.27 (83)	2.20 (56)	1.97 (50)	1.67 (42.5)	1.50 (38)

\* These values are nominal since the dimension is not controlled to a tolerance. The "k" dimension should be measured when the hook is new - this becomes a reference measurement. Subsequent measurements are compared to this reference to make determinations about hook deformation/stretch. See [Section 5.7](#), "Hooks - Stretch".

**Table 5-5 Chain Wear Dimensions**

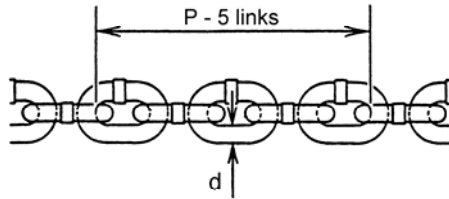

Capacity Code	"P" Dimension inch (mm)		"d" Dimension inch (mm)	
	Standard	Discard	Standard	Discard
001H, 003S,	2.97 (75.5)	3.02 (76.6)	0.22 (5.0)	0.18 (4.5)
003H, 005L, 005S	3.76 (95.5)	3.82 (96.9)	0.25 (6.3)	0.22 (5.7)
010L, 010M, 010S	4.76 (121.0)	4.91 (124.6)	0.31 (8.0)	0.28 (7.2)
015S, 020L, 020M, 020S, 030C	5.96 (151.5)	6.05 (153.8)	0.39 (10.0)	0.35 (9.0)
025S, 050L	6.75 (171.5)	6.85 (174.1)	0.44 (11.2)	0.40 (10.1)
030L, 030S	7.52 (191)	7.74 (196.7)	0.49 (12.5)	0.44 (11.3)

**Table 5-6 Motor Brake Wear Dimensions**

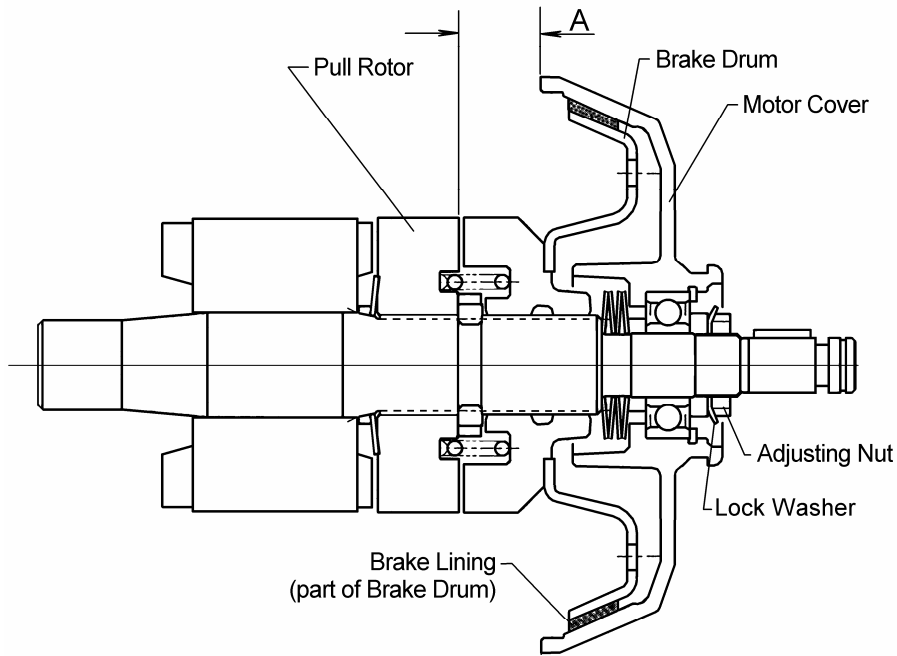

**NOTICE**

Brake must be properly adjusted before measuring "A". See [Section 6.3](#)

Capacity Code	"A" Dimension - inch (mm)			
	Single Speed		Dual Speed	
	Standard	Discard	Standard	Discard
001H, 003S, 005L	0.67 (17)	0.61 (15.5)	0.67 (17)	0.61 (15.5)
003H, 005S, 010L, 010M	0.85 (21.5)	0.79 (20)	0.85 (21.5)	0.79 (20)
010S, 015S, 020L, 020M, 030C	0.89 (22.5)	0.83 (21)	1.06 (27)	1.00 (25.5)
020S, 025S, 030L, 030S, 050L	0.83 (21)	0.77 (19.5)	1.54 (39)	1.48 (37.5)

## 6.0 Maintenance and Handling

### 6.1 Count/Hour Meter

- 6.1.1 The Count/Hour (C/H) Meter located in on the electrical control panel records the hoist's on time and number of starts. To view the two values press the button on the C/H Meter one time. The display will first show an "H" and a 4 digit number which is the hoist's total on time (up and down) in hours. After 3 seconds the display will automatically change to a 6 digit number which is the number of starts of the hoist's down contactor. Refer to [Figure 6-1](#).

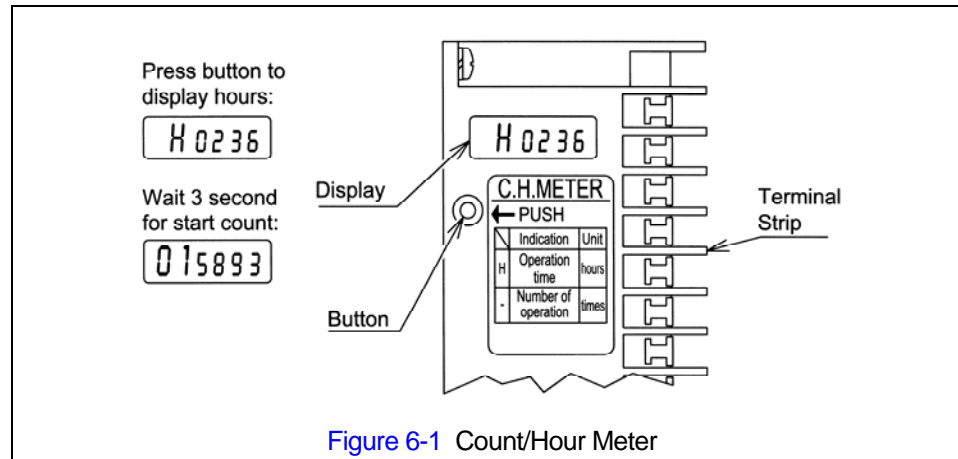

Figure 6-1 Count/Hour Meter

- 6.1.2 Contactor – The C/H Meter can be used in conjunction with the amount of jogging to estimate when the contactor(s) should be replaced. Jogging is when the pendant control buttons are pressed quickly and repetitively to move the hook in small increments. Refer to [Table 6-1](#).

Table 6-1 Criteria for Recommended Contactor Replacement		
Jogging During Normal Operation		Change Contactor After: (starts)
Rating	Approximate Jogging Frequency	
Low	Jogging is rare.	1,000,000
Medium	During 25% of operations/lifts.	500,000
High	During 50% or more of operations/lifts.	200,000

- 6.1.3 Gear Oil – The C/H Meter can be used in conjunction with the average load lifted by the hoist to estimate when the gear oil should be changed. Refer to [Table 6-2](#).

Table 6-2 Criteria for Recommended Gear Oil Replacement		
Loading During Normal Operation		Change Gear Oil After: (hours)
Rating	Average % of Rated Capacity	
Light	0 to 33%	360
Medium	33 to 67%	240
Heavy	67 to 100%	120

- 6.1.4 You are encouraged to use the Count/Hour Meter in conjunction with your experience with the hoist's application and usage to develop a history upon which to gage and fine tune your maintenance program for the hoist.

## 6.2 Lubrication

### 6.2.1 Load Chain

- For longer life, the load chain should be lubricated.
- The load chain lubrication should be accomplished after cleaning the load chain with an acid free cleaning solution.
- Apply Harrington lubricating grease (Part No. ER1BS1951) or an equivalent to industrial general lithium grease, NLGI No. 0, to the bearing surfaces of the load chain links as indicated by the shaded areas in [Figure 6-2](#). Also apply the grease to the areas of the load chain (shaded areas in [Figure 6-2](#)) that contact the load sheave. Insure that the grease is applied to the contact areas in the load sheave pockets.
- Machine or gear oil (grade ISO VG 46 or 68 oil or equivalent) may be used as an alternative lubricant but must be applied more frequently.

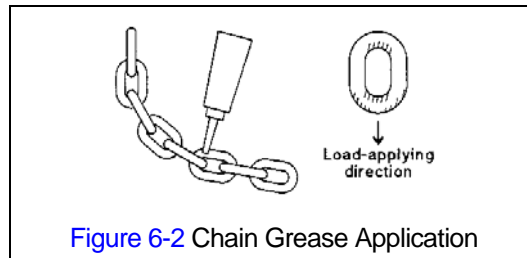

- The chain should be lubricated every 3 months (more frequently for heavier usage or severe conditions).
- For dusty environments, it is acceptable to substitute a dry lubricant.

### 6.2.2 Hooks and Suspension Components:

- Hooks - Bearings should be cleaned and lubricated at least once per year for normal usage. Clean and lubricate more frequently for heavier usage or severe conditions.
- Suspension Pins - Lubricate at least twice per year for normal usage; more frequently for heavier usage or severe conditions.

### 6.2.3 Gear Box:

- **⚠ WARNING** Using an incorrect type/grade of gearbox oil or the wrong quantity of oil may prevent the friction clutch from working properly and may affect the ability of the hoist to hold the load. Refer to [Section 3.1](#) for the correct oil and quantity.
- The oil level can be checked using the oil check hole on the side of the hoist body shown in [Figure 3-1](#). The oil level should be in accordance with [Table 6-3](#) below.

<b>Table 6-3 Criteria for Checking Hoist Gear Oil Level</b>		
<b>Capacity Code</b>	<b>Oil Level (Hoist at level position)</b>	
	<b>Min</b>	<b>Max</b>
Up to and including 010M	½ " below bottom edge of check hole	Even with bottom edge of check hole.
010S and Up	1" below bottom edge of check hole	Even with bottom edge of check hole.

- Change gear oil at least once every 5 years. The oil should be changed more frequently depending on the hoist's usage and operating environment. Refer to [Section 6.1](#).
- Refer to [Figure 3-1](#) and [Table 3-1](#) to change the gear oil, remove both fill and drain plugs and allow the old oil drain completely. Replace the drain plug and refill the gear case with the correct quantity of new oil or until the oil level is within the range shown in [Table 6-3](#).
- **NOTICE** Dispose of the used oil in accordance with local regulations.

### 6.3 Motor Brake

6.3.1 To keep your hoist working in optimum condition and prevent possible down time, it is recommended to check your motor brake lining and adjustment at regular intervals.

6.3.2 Motor Brake Unit Removal - Adjustment and inspection of the motor brake requires removal of the motor brake unit from the hoist as an assembly.

- 1) **CAUTION** Before proceeding disconnect the power supply and make sure the hoist is unloaded. To keep the load chain from moving secure it by tying together the load and no-load sides directly under the hoist using a cord or wire.
- 2) Refer to [Figure 6-3](#).
- 3) Remove the four Fan Cover bolts (A), Fan Cover (B), Fan snap ring (C), and Fan washer (D).
- 4) Pull the Fan (E) off the motor shaft using a wheel puller if necessary.
- 5) Remove the four Motor Cover Assembly bolts (F) and carefully pull the motor brake unit (G) out of the hoist.

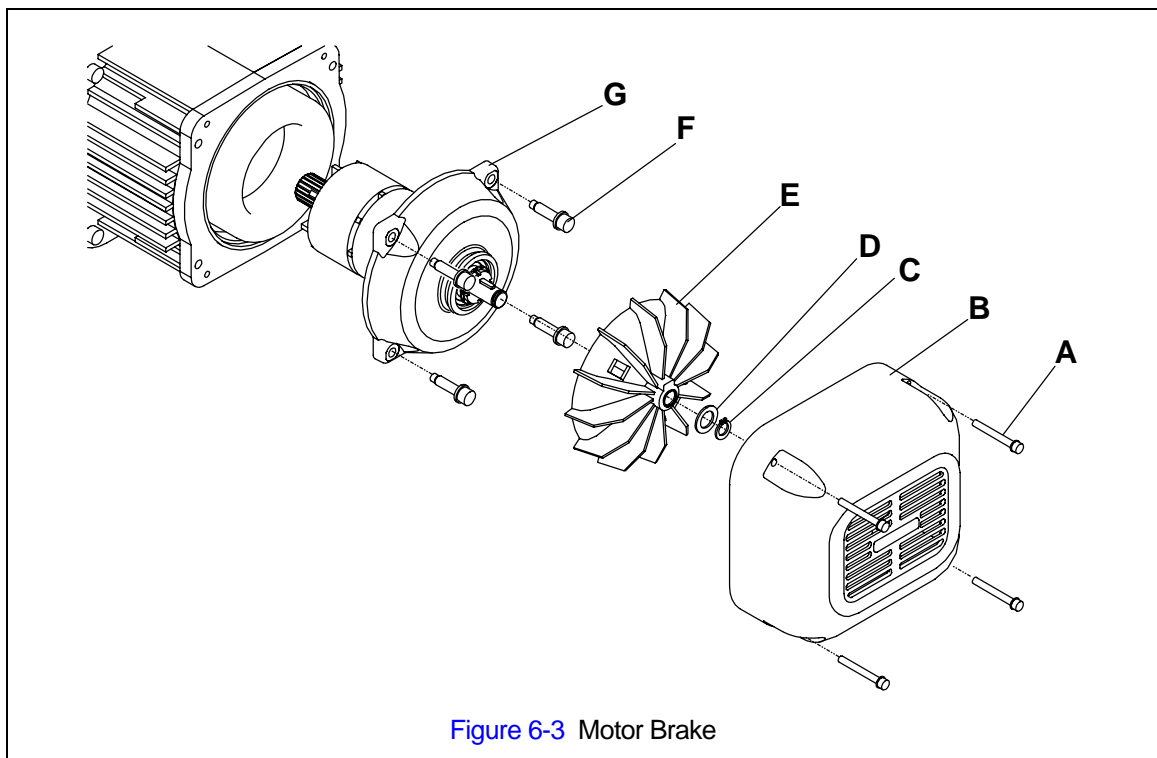
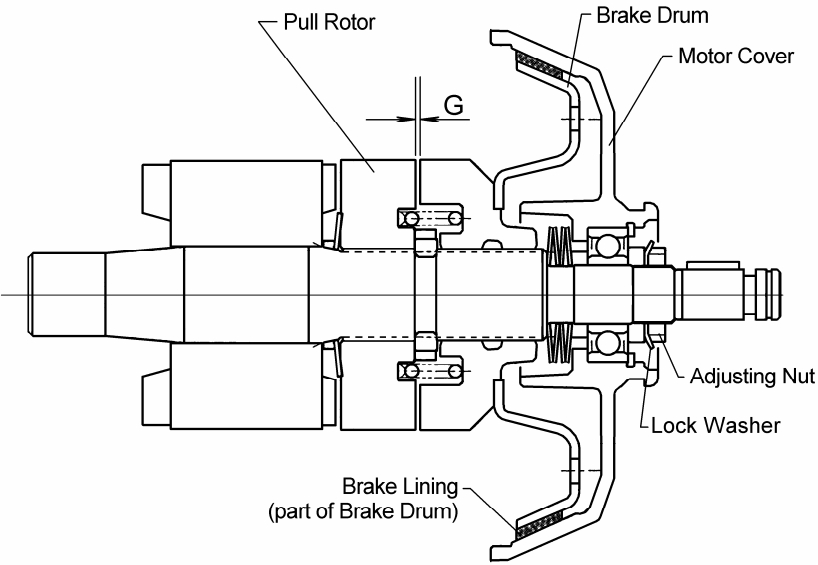

Figure 6-3 Motor Brake

6.3.3 Brake Gap (G) - The Brake Gap should be measured between the Brake Drum and Pull Rotor. Adjustment of the Brake Gap is accomplished by turning the Adjustment Nut in the center of the Motor Cover as shown in the figure with [Table 6-4](#). Do this as follows:

- 1) Bend the tab of the Lock Washer away from the Adjusting Nut so that the Adjusting Nut can be rotated.
- 2) Using a spanner wrench and a feeler gauge, rotate the Adjusting Nut to attain the proper Brake Gap per [Table 6-4](#).
- 3) After the Brake Gap is set, secure the Adjusting Nut by bending one of the tabs of the Lock Washer into a slot in the Adjusting Nut. If necessary rotate the Adjusting Nut clockwise (tightening) to line up the tab with the slot.
- 4) If the proper brake adjustment cannot be achieved, disassemble the motor brake and inspect all motor brake parts. Replace the Brake Drum and/or Motor Cover if necessary.

<b>Table 6-4 Motor Brake Gap</b>	
	
Capacity Code	Brake Gap (G) inch (mm)
001H, 003S, 005L, 003H, 005S, 010L, 010M, 010S, 015S, 020L, 020M, 030C	0.020 (0.5)
020S, 025S, 030L, 030S, 050L	0.032 (0.8)

6.3.4 Brake Lining Inspection –The brake lining is designed for a long life and should provide years of trouble-free service. If the brake lining is being inspected due to excessive load chain drift during operation (see [Section 5.7](#)), disassemble the motor brake and inspect all motor brake parts. Braking surfaces should be clean, free of grease/oil and should not be glazed. Replace the Brake Drum and/or Motor Cover if necessary. For normal inspections, the Brake Lining and Motor Cover wear should be measured as follows.

- 1) Adjust the Brake Gap per [Section 6.3.3](#) before measuring the Brake Lining and Motor Cover wear.
- 2) Refer to [Table 5-6](#).
- 3) Measure the distance "A" using calipers and a straight edge. Place the straight edge across the edge of the motor cover and measure from the straight edge to the face of the Pull Rotor.
- 4) Compare the measurement with the values listed in [Table 5-6](#). Replace the Brake Drum and/or Motor Cover if the "A" measurement is smaller than the discard limit.

- 6.3.5 Motor Brake Unit Installation - After the brake is properly adjusted and inspected, carefully replace the motor brake unit back into the hoist. Be sure to reseal the Motor Cover to motor frame surface using a small bead of liquid (hi-temperature) sealant. Refer to [Section 6.3.2](#) and reassemble the parts in reverse order of removal.

## 6.4 Load Chain

- 6.4.1 Lubrication and Cleaning – refer to [Section 6.2](#).

- 6.4.2 Load Chain Replacement:

- 1) **⚠ CAUTION** The hoist must be properly powered and operational in order to perform the following procedures.
- 2) **⚠ WARNING** Be certain that the replacement chain is obtained from Harrington and is the exact size, grade and construction as the original chain. The new load chain must have an odd number of links so that both its end links have the same orientation. If the load chain is being replaced due to damage or wear out, destroy the old chain to prevent its reuse.
- 3) **⚠ CAUTION** When replacing load chain, check for wear on mating parts, i.e. Load Sheave, Chain Guides and Idle Sheaves, and replace parts if necessary.
- 4) Remove all chain components including the Bottom Hook Set Assembly, Stoppers, Cushion Rubbers, Chain Springs, Striker Plates, Chain Pin and End Wire (or End Suspender) from the chain for reuse on new chain. Inspect and replace any damaged or worn parts.
- 5) Using a C-link, attach the new chain to the end link of the old chain on the no-load side. The end link of the new load chain should be connected so that the welded portions of the load chain's standing links are oriented to the outside as they pass over the sheave. Refer to [Figure 6-4](#).
- 6) Operate the hoist down to move the chain through the hoist body. Stop when a sufficient amount of new chain is accumulated on the load side.
- 7) Single fall hoists - Attach the chain components (step 4 above) to the chain. Refer to [Section 3.2](#) for the proper locations.
- 8) Double falls (030C, 050L) - Feed the end link on the load side of the new chain through the required chain components (step 4 above) and the bottom hook's Idle Sheave. Attach the remaining chain components to the chain referring to [Section 3.2](#) for the proper locations. Connect the end link to the top connection yoke with the chain pin, slotted nut and cotter pin. Ensure that chain remains free of twists. Refer to [Figures 3-6](#) and [3-7](#).
- 9) **⚠ WARNING** Make sure Stoppers, Cushion Rubbers, Chain Springs and Striker Plates are properly installed. Refer to [Section 3.2](#).
- 10) After installation has been completed, perform steps outlined in [Section 3.6](#) "Preoperational Checks and Trial Operation".

## 6.5 Friction Clutch and Mechanical Load Brake with Friction Clutch

- 6.5.1 Friction Clutch (NER Models) – If abnormal operation or slippage occurs do NOT attempt to disassemble or adjust the Friction Clutch. Replace the worn or malfunctioning Friction Clutch as an assembly with a new, factory adjusted part.
- 6.5.2 Mechanical Load Brake with Friction Clutch (ER Models) – If abnormal operation or slippage occurs do NOT attempt to disassemble or adjust the Mechanical Load Brake with Friction Clutch. Replace the worn or malfunctioning Mechanical Load Brake with Friction Clutch as an assembly with a new, factory adjusted part.

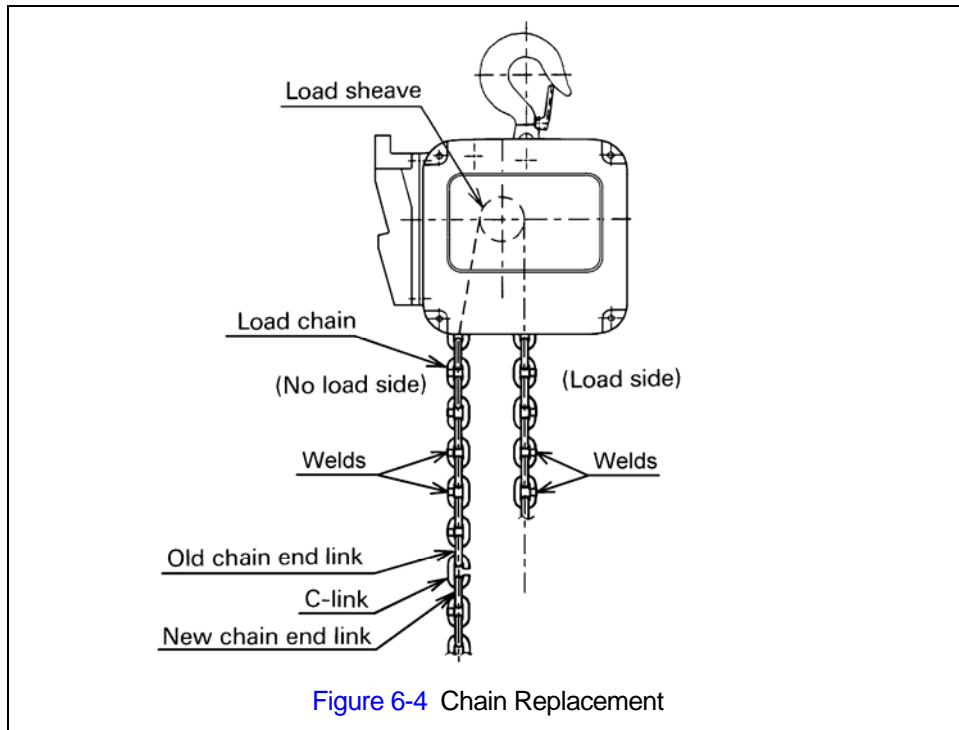

## 6.6 Storage

- 6.6.1 ER models with vented oil cap assemblies should be stored with the cap oriented up to prevent oil leakage.
- 6.6.2 The storage location should be clean and dry.

## 6.7 Outdoor Installation

- 6.7.1 For hoist installations that are outdoors, the hoist should be covered when not in use.
- 6.7.2 Possibility of corrosion on components of the hoist increases for installations where salt air and high humidity are present. Make frequent and regular inspections of the unit's condition and operation.

## 7.0 Troubleshooting

### **WARNING**

#### **HAZARDOUS VOLTAGES ARE PRESENT IN THE HOIST AND IN CONNECTIONS BETWEEN COMPONENTS.**

Before performing ANY troubleshooting on the equipment, de-energize the supply of electricity to the equipment, and lock and tag the supply device in the de-energized position. Refer to ANSI Z244.1, "Personnel Protection - Lockout/Tagout of Energy Sources."

Only Trained and competent personnel should inspect and repair this equipment.

**Table 7-1 Troubleshooting Guide**

Symptom	Cause	Remedy
Hoist moving in wrong direction	Power supply reversed phased	Switch 2 of the 3 power supply cord wires at the power source.
	Improper electrical connections	Refer to wiring diagram and check all connections.
Hoist will not operate	Loss of power	Check circuit breakers, switches, fuses and connections on power lines/cable.
	Wrong voltage or frequency	Check voltage and frequency of power supply against the rating on the nameplate of the motor.
	Hoist overload	Reduce load to within rated capacity of hoist.
	Motor overheated and thermal overload protector has tripped	See Trouble Shooting Problem "Motor or brake overheating".
	Improper, loose, or broken wire in hoist electrical system	Shut off power supply, check wiring connections on hoist control panel and inside push-button pendant.
	Brake does not release	Check motor brake adjustment for proper clearance.
	Faulty magnetic contactor	Check coil for open or short circuit. Check all connections in the control circuit. Check for open contactors. Replace as needed.
	Defect in control transformer	Check transformer coil for signs of overheating. Disconnect transformer and check for open winding.
Motor burned out	Replace motor frame/stator, shaft/rotor, and any other damaged parts.	

**Table 7-1 Troubleshooting Guide**

<b>Symptom</b>	<b>Cause</b>	<b>Remedy</b>
Hoist lifts but will not lower	Down circuit open	Check circuit for loose connections. Check down side of limit switch for malfunction.
	Broken conductor in pendant cord	Check the continuity for each conductor in the cable. If one is broken, replace entire cable.
	Faulty magnetic contactors	Check coils for open or short circuit. Check all connections on motor circuit. Check for burned contacts. Replace as needed.
	Faulty switch in pendant	Check electrical continuity. Check electrical connections. Replace or repair as needed.
Hoist lowers but will not lift	Hoist overloaded	Reduce load to within rated capacity of hoist.
	Low voltage in hoist's power supply	Determine cause of low voltage and bring to within plus or minus 10% of the voltage specified on the motor nameplate. The voltage should be measured at the hoist contactor.
	Up circuit open	Check circuit for loose connections. Check up side of limit switch for malfunction.
	Broken conductor in pendant cord	Check the continuity of each conductor in the cable. If one is broken, replace entire cable.
	Faulty magnetic contactor	Check coils for open or short circuit. Check all connections on motor circuit. Check for burned contacts. Replace as needed.
	Faulty switch in pendant	Check electrical continuity. Check electrical connections. Replace or repair as needed.
	Faulty friction clutch	Replace.
Hoist will not lift rated load or does not have the proper lifting speed	Hoist overloaded	Reduce load to within rated capacity.
	Low voltage in hoist's power supply	Determine cause of low voltage and bring to within plus or minus 10% of voltage specified on the motor nameplate. The voltage should be measured at the hoist contactor.
	Brake drags	Check motor brake adjustment for proper clearance.
	Faulty friction clutch	Replace.
Load drifts excessively when hoist is stopped	Motor brake not holding	Clean and inspect brake lining. Check brake adjustment for proper clearance.
	Mechanical Load brake not holding (ER only)	Replace as needed. (ER only, NER has no load brake.)

**Table 7-1 Troubleshooting Guide**

<b>Symptom</b>	<b>Cause</b>	<b>Remedy</b>
Motor or brake overheating	Excessive load	Reduce load to within rated capacity of hoist.
	Excessive duty cycle	Reduce frequency of lifts.
	Wrong voltage or frequency	Check voltage and frequency of power supply against the rating on the nameplate on the motor.
	Brake drags	Check brake adjustment for proper clearance.
	Extreme external heating	Above an ambient temperature of 140°F, the frequency of hoist operation must be reduced to avoid overheating of the motor. Special provisions should be made to ventilate the hoist or otherwise shield it from the heat.
Hoist operates intermittently	Collectors making poor contact	Check movement of spring loaded arm, weak spring, connections, and shoe. Replace as needed.
	Contactors contacts arcing	Check for burned contacts. Replace as needed.
	Loose connection in circuit	Check all wires and terminals for bad connections. Replace as needed.
	Broken conductor in Pendant Cord	Check for intermittent continuity in each conductor the Pendant Cord. Replace entire Pendant Cord if continuity is not constant.

## 8.0 Material Safety Data Sheets

### NOTICE

The ER and NER hoists are shipped new with the oil for the gear box and the grease for the load chain in separate container(s). In compliance with OSHA regulations, Material Safety Data Sheets (MSDS) have been provided for the gear oil that is provided in this separate container. The ER (with mechanical load brake/friction clutch) uses different gear oil than the NER (with friction clutch). Identify the correct model (refer to [Section 2.1](#)) before using the MSDS's below.

### 8.1 ER Model Gear Box Oil Material Safety Data Sheet (MSDS)

Effective date: June 9, 1998	MSDS No. 414005	
SECTION I CHEMICAL PRODUCT AND COMPANY IDENTIFICATION		
COMPANY IDENTIFICATION	NIPPON OIL COMPANY, LTD. 3-12, Nishi Shimbashi 1-chome, Minato-ku, Tokyo, 105-8412, Japan	
EMERGENCY TELEPHONE NUMBER:	+81-3-3502-9156	
TELEPHONE NUMBER FOR INFORMATION:	+81-3-3502-1111	
FAX NUMBER FOR INFORMATION:	+81-3-3502-3364	
PRODUCT NAME:	ANTOIL SUPER B	
PRODUCT USE:	Common lubricating oil for tractors	
SECTION II COMPOSITION/INFORMATION ON INGREDIENTS		
COMPOSITION		
<u>Components</u>	<u>Amount (%)</u>	<u>Limit</u>
Highly refined petroleum oil	>92	5mg/m <sup>3</sup> TWA-OSHA (Mineral Oil Mist #1) 5 mg/m <sup>3</sup> TWA-ACGIH (Mineral Oil Mist #1)
Additives	>8	
Anti-foam additives		
Detergents-dispersants		
Oxidation inhibitors		
<u>Hazardous Information</u>		
Product is non-hazardous. (1910, 1200 OSHA)		
#1 Highly refined petroleum oil, by definition, is considered hazardous according OSHA. Because it carries the Threshold Limit Value (TLV) for mineral oil mist.		

SECTION III HAZARDS IDENTIFICATION	
EMERGENCY OVERVIEW	
Warning statement:	
Caution!	Prolonged or repeated contact with skin may cause irritation in some cases.
Precautionary Measures:	
	Avoid breathing vapor and mist. Keep container closed.
	Avoid contact with eyes, skin, and clothing.
	Wash thoroughly after handling. Keep away from heat.
Potential health effect:	
Eyes:	May cause minor irritation.
Skin:	May cause minimal skin irritation.
Inhalation:	Vapor or mist, in excess of permissible concentrations, or in unusually high concentrations generated from spraying, heating the material, or as from exposure in poorly ventilated areas or confined spaces, may cause irritation of the nose and throat, headache, nausea and drowsiness.
Ingestion:	May cause abdominal discomfort, nausea or diarrhea.
Sensitization properties:	Unknown
Chronic Properties:	If prolonged exposure occurs, nausea, headache, diarrhea, and physical discomfort.
Other remarks:	None
SECTION IV FIRST AID MEASURES	
Eyes:	Flush immediately with water for at least 15 minutes. Get immediate medical attention.
Skin:	Wash with soap and water. Get medical attention if irritation develops. Launder contaminated clothing before reuse.
Inhalation:	Remove exposed person to fresh air if adverse effects are observed.
Ingestion:	Do not make person vomit unless directed to do so by medical personnel.
Note to physician:	Treat symptomatically.
SECTION V FIRE FIGHTING MEASURES	
Flash point (Typical), °C:	234(COC)
Autoignition tempt., °C:	Not Determined
Flammability limits:	Not Determined
Extinguishing media:	Carbon Dioxide (CO <sub>2</sub> ), dry chemical, or foam.
Special fire fighting procedures:	Recommend wearing self-contained breathing apparatus. Water may cause splattering. Material will float on water.
Unusual fire & explosion hazards:	Toxic fumes, gases or vapors may evolve on burning.
Autoignition temperature:	Not determined.
Explosion date:	Material does not have explosive properties.

SECTION VI ACCIDENTAL RELEASE MEASURES		
Procedures in Case of Accidental Release, Breakage, or Leakage: Stop the source of the leak or release. Clean up releases as soon as possible. Contain liquid to prevent further contamination of soil, surface water or groundwater. Clean up small spills using appropriate techniques such as absorbent materials or pumping. Where feasible and appropriate, remove contaminated soil. Follow prescribed procedures for reporting and responding to larger releases.		
SECTION VII HANDLING AND STORAGE		
Do not weld, heat or drill container. Replace cap or bung. Emptied container still contains hazardous material which may ignite with explosive violence if heated sufficiently. Minimum feasible handling temperature should be maintained. Periods of exposure to high temperatures should be minimized. Water contamination should be avoided. CAUTION: Do not use pressure to empty drum or drum may rupture with explosive force.		
SECTION VIII EXPOSURE CONTROLS/PERSONAL PROTECTION		
Eye Protection:	Chemical type goggles or face shield optional.	
Skin Protection:	Avoid prolonged or frequently repeated skin contact by wearing impervious protective clothing including gloves.	
Respiratory Protection:	Wear a breathing mask.	
Ventilation:	No special ventilation is usually necessary. However, if operating conditions create high air borne concentrations of this material, special ventilation may be needed.	
Other clothing and equipment:	No special clothing or equipment is usually necessary.	
Work practices, hygienic practices:	No information is available.	
Other handling and storage requirements:	No information is available.	
Protective measures during maintenance of contaminated equipment:	No data available.	
SECTION IX PHYSICAL AND CHEMICAL PROPERTIES		
Odor		Slight odor
Appearance		Light brown liquid
Boiling point	°C	No Data Available
Solubility		Insoluble in water
Density	@15°C, g/cm <sup>3</sup>	0.885
Pour point	°C	-42.5
DMSO Extract (Base oil)	Mass % (IP 346)	< 3

SECTION X STABILITY AND REACTIVITY	
Stability:	Stable
Condition to Avoid:	See the Handling and Storage section for further details.
Incompatibility (materials to avoid):	Acids. Oxidizing agents. Halogens and halogenated compounds.
Hazardous Polymerization:	Will not occur.
Thermal decomposition:	Smoke, carbon monoxide, aldehydes and other products of incomplete combustion. Hydrogen sulfide and alkyl mercaptans and sulfides may also be released. Under combustion conditions, oxides of the following elements will be formed: Calcium, Sulfur, Zinc.
SECTION XI TOXICOLOGICAL INFORMATION	
Acute Oral:	No Data Available Believed to be greater than 5 g/kg (rat) Practically non-toxic
Dermal:	No Data Available Believed to be greater than 3 g/kg (rabbit) Practically non-toxic
Carcinogen:	OSHA This material is listed as Group 3 by IARC (Base oil) EU The classification as a carcinogen need not apply.
SECTION XII ECOLOGICAL INFORMATION	
Biodegradation:	No Data Available
Environmental fate:	This material is not expected to present any environmental problems other than those associated with oil spills.
SECTION XIII DISPOSAL CONSIDERATIONS	
Waste Disposal Method: Place contaminated materials in disposable containers and dispose of in a manner consistent with applicable regulations. Contact local environmental or health authorities for approved disposal of this material.	
SECTION XIV TRANSPORT INFORMATION	
The description shown may not apply to all shipping situations.	
DOT Proper Shipping Name:	Not applicable
IMDG Proper Shipping Name:	Not applicable
ICAO Proper Shipping Name:	Not applicable
TDG Proper Shipping Name:	Not applicable
NFPA Proper name:	Class 1.
UN Number:	Not applicable

SECTION XV REGULATION INFORMATION

The U.S. TSCA inventory: All components of this material are on the US TSCA inventory.

The EC EINECS inventory: All components of this material are on the EC EINECS inventory.

The CANADA DSL inventory: May require notification before sale in CANADA.

The AUSTRALIA AICS inventory: May require notification before sale in AUSTRALIA.

The KOREA TCCL inventory: May require notification before sale in KOREA.

The PHILIPPINE PICCS inventory: No Data Available.

SECTION XVI OTHER INFORMATION

None

References:

1. Handbook of Toxic and Hazardous Chemicals and Carcinogens (2<sup>nd</sup>. ed.)
2. Registry of Toxic Effects of Chemical Substances (HIOSH, 1983)

Material safety data sheets are provided as reference information on the safe handling of hazardous or harmful materials to companies using such materials. When referring to this data sheet, companies should remember that they must take responsibility for implementing the proper measures for their own particular situations. This data sheet is not a guarantee of safety.

## 8.2 NER Model Gear Box Oil Material Safety Data Sheet (MSDS)

SECTION I		
MANUFACTURER'S NAME Nippon Oil Co., Ltd.	EMERGENCY TELEPHONE NUMBER 03-3502-9161	TELEPHONE NUMBER FOR INFORMATION 03-3502-1111
ADDRESS 3-12, Nishi Shimbashi 1-chome, Nimato-ku, Tokyo, 105 Japan		
DATE PREPARED Oct. 14, 1992	SIGNATURE OF PREPARER Signature on file at Harrington Hoists, Inc.	
TRADE NAME AND SYNONYMS BONNOC M 260	CHEMICAL NAME AND SYNONYMS Industrial gear oil	
WARNING STATEMENT CAUTION: Prolonged or repeated inhalation of fumes or contact with skin can be harmful.		
SECTION II TYPICAL COMPOSITION		
Base oil: (highly refined mineral oil)		>94%
Additives: (Oxidation inhibitor, Rust inhibitor, Emulsion breaker, Antiwear Agent, Antifoamer, Friction modifier)		<6%
Notes: These materials are listed in TSCA chemical substance inventory. The carcinogens that are listed in federal OSHA, IARC, NTP are not used in this product.		
SECTION III EXPOSURE STANDARD		
No OSHA exposure or Threshold Limit Value (TLV) has been established for this material. The suggested TLV is 5 mg/m <sup>3</sup> for a daily 8-hour exposure.		
This is the OSHA exposure standard and the TLV (1990-1991) for mineral oil mists.		
SECTION IV OCCUPATIONAL CONTROL PROCEDURES		
Eye protection:	Chemical type goggles or face shield optional.	
Skin protection:	Avoid prolonged or frequently repeated skin contact with wearing impervious protective clothing including gloves.	
Respiratory protection:	No special respiratory protection is normally required.	
Ventilation:	No special ventilation is usually necessary. However, if operating condition create high airborne concentrations of this material, special ventilation may be needed.	
Other clothing and equipment:	No special clothing and equipment is usually necessary.	
Work practices, hygienic practices:	No information is available.	
Other handling and storage requirements:	No information is available.	
Protective measures during maintenance contaminated equipment:	No information is available.	

SECTION V HEALTH HAZARD INFORMATION	
SYMPTOMS OF OVEREXPOSURE FOR EACH POTENTIAL ROUTE OF EXPOSURE	
Inhalation:	Not expected to be acutely toxic by inhalation.
Skin:	Expected to cause no more than minor skin irritation, but prolonged or frequently repeated skin contact may be harmful.
Eyes:	Expected to cause no more than minor irritation.
Absorption through skin:	No information is available.
Ingestion:	Not expected to be acutely toxic by ingestion.
HEALTH EFFECTS OR RISK FROM EXPOSURE	
Acute:	No information is available.
Chronic:	No information is available.
MEDICAL CONDITIONS AGGRAVATED BY EXPOSURE	
No information is available.	
SECTION VI EMERGENCY AND FIRST AID PROCEDURES	
Eyes:	Wash eyes with fresh water for at least 15 minutes. If irritation continues, see a doctor.
Skin:	Wash skin thoroughly with soap and water. Launder contaminated clothing.
Inhalation:	None considered necessary.
Ingestion:	If swallowed, give a large amount of water to drink, make person vomit and call a doctor.
Sensitization property:	Unknown
SECTION VII MEDIAN LETHAL DOSE (LD <sub>50</sub> )	
Oral:	N.D. ; Believed to be greater than 5g/kg (rat) ; Practically non-toxic
Dermal:	N.D. ; Believed to be greater than 3g/kg (rabbit) ; Practically non-toxic
SECTION VIII FIRE PROTECTION INFORMATION	
Flash Point °C	240
Autoignition Temp. °C	N. D.
Flammability Limits	N. D.
Extinguishing Media:	Carbon Dioxide (CO <sub>2</sub> ), Dry chemical foam, Water fog, or spray.
SECTION IX REACTIVITY DATA	
Stability:	<u>    X    </u> Stable <u>                    </u> Unstable
Conditions to avoid:	Do not store at high temperature.
Incompatibility (materials to avoid):	May react with strong oxidizing materials.
Hazardous polymerization:	<u>                    </u> May occur <u>    X    </u> Will not occur

NER Model Gear Box Oil Material Safety Data Sheet (MSDS) - continued

<b>SECTION X REQUIREMENTS FOR TRANSPORTATION, HANDLING, AND STORAGE</b>			
Minimum feasible handling temperatures should be maintained. Periods of exposure to high temperatures should be minimized. Water contamination should be avoided.			
<b>SECTION XI SPILL, LEAK, AND DISPOSAL PROCEDURES</b>			
<b>PROCEDURES IN CASE OF BREAKAGE OR LEAKAGE</b> Wipe up or absorb on suitable material and shovel up.			
<u><b>WASTE DISPOSAL METHOD</b></u> Place contaminated materials in disposable containers and bury in an approved dumping area.			
<b>SECTION XII CHEMICAL AND PHYSICAL PROPERTIES</b>			
Density	15°C g/cm <sup>3</sup>		0.900
Viscosity	C5t @40°C		260
Solubility			Insoluble in water
Boiling point			N. D.
Evaporation rate			N. D.
Vapor pressure	mmHg		N. D.
Vapor Density			N. D.
PH of undiluted product			N. D.
Percent Volatile by volume			N. D.
Appearance			Green colored liquid
Odor			Little odor
N. D. – not determined			

### 8.3 (N)ER Model Load Chain Grease Material Safety Data Sheet (MSDS)

Effective date: November 9, 1999		MSDS No. 601008	
SECTION 1. CHEMICAL PRODUCT AND COMPANY IDENTIFICATION			
COMPANY IDENTIFICATION	NIPPON MITSUBISHI OIL CORPORATION 3-12, Nishi Shimbashi 1-chome, Minato-ku, Tokyo, 105-8412, Japan		
EMERGENCY TELEPHONE NUMBER:	+81-3-3502-9168		
TELEPHONE NUMBER FOR INFORMATION:	+81-3-3502-1111		
FAX NUMBER FOR INFORMATION:	+81-3-3502-9365		
PRODUCT NAME:	EPNOC GREASE AP O		
PRODUCT USE:	Lubricating grease		
SECTION 2. COMPOSITION/INFORMATION ON INGREDIENTS			
COMPOSITION			
<u>Components</u>	<u>Amount (%)</u>	<u>Limit</u>	
Highly refined petroleum oil	>89	5mg/m <sup>3</sup> TWA-OSHA (Mineral Oil Mist #1) 5 mg/m <sup>3</sup> TWA-ACGIH (Mineral Oil Mist #1)	
Thickener (Lithium Soap)	< 4		
Additives	< 7		
Friction Modifiers			
Oxidation Inhibitors			
Rust Inhibitors			
<u>Hazardous Information</u>			
#1 Highly refined petroleum oil, by definition, is considered hazardous according OSHA. Because it carries the Threshold Limit Value (TLV) for mineral oil mist.			

SECTION 3. HAZARDS IDENTIFICATION

EMERGENCY OVERVIEW

Warning statement:

Caution! Prolonged or repeated contact with skin may cause irritation in some cases.

Precautionary Measures:

Avoid breathing vapor and mist. Keep container closed.

Avoid contact with eyes, skin, and clothing.

Wash thoroughly after handling. Keep away from heat.

Potential health effect:

Eyes: May cause minor irritation.

Skin: May cause minimal skin irritation.

Inhalation: Vapor or mist, in excess of permissible concentrations, or in unusually high concentrations generated from spraying, heating the material, or as from exposure in poorly ventilated areas or confined spaces, may cause irritation of the nose and throat, headache, nausea and drowsiness.

Ingestion: May cause abdominal discomfort, nausea or diarrhea.

Sensitization properties: Unknown

Chronic Properties: If prolonged exposure occurs, nausea, headache, diarrhea, and physical discomfort.

Other remarks: None

SECTION 4. FIRST AID MEASURES

Eyes: Flush immediately with water for at least 15 minutes. Get immediate medical attention.

Skin: Wash with soap and water. Get medical attention if irritation develops. Launder contaminated clothing before reuse.

Inhalation: Remove exposed person to fresh air if adverse effects are observed.

Ingestion: Do not make person vomit unless directed to do so by medical personnel.

Note to physician: Treat symptomatically.

SECTION 5. FIRE FIGHTING MEASURES

Flash point (Typical), °C: Not Determined

Autoignition tempt., °C: Not Determined

Flammability limits: Not Determined

Extinguishing media: Carbon Dioxide (CO<sub>2</sub>), dry chemical, or foam.

Special fire fighting procedures: Recommend wearing self-contained breathing apparatus. Water may cause splattering. Material will float on water.

Unusual fire & explosion hazards: Toxic fumes, gases or vapors may evolve on burning.

Explosion date: Material does not have explosive properties.

<b>SECTION 6. ACCIDENTAL RELEASE MEASURES</b>		
Procedures in Case of Accidental Release, Breakage, or Leakage: Stop the source of the leak or release. Clean up releases as soon as possible. Contain liquid to prevent further contamination of soil, surface water or groundwater. Clean up small spills using appropriate techniques such as absorbent materials or pumping. Where feasible and appropriate, remove contaminated soil. Follow prescribed procedures for reporting and responding to larger releases.		
<b>SECTION 7. HANDLING AND STORAGE</b>		
Do not weld, heat or drill container. Replace cap or bung. Emptied container still contains hazardous material which may ignite with explosive violence if heated sufficiently. Minimum feasible handling temperature should be maintained. Periods of exposure to high temperatures should be minimized. Water contamination should be avoided. CAUTION: Do not use pressure to empty drum or drum may rupture with explosive force.		
<b>SECTION 8. EXPOSURE CONTROLS/PERSONAL PROTECTION</b>		
Eye Protection:	Chemical type goggles or face shield optional.	
Skin Protection:	Avoid prolonged or frequently repeated skin contact by wearing impervious protective clothing including gloves.	
Respiratory Protection:	Wear a breathing mask.	
Ventilation:	No special ventilation is usually necessary. However, if operating conditions create high air borne concentrations of this material, special ventilation may be needed.	
Other clothing and equipment:	No special clothing or equipment is usually necessary.	
Work practices, hygienic practices:	No information is available.	
Other handling and storage requirements:	No information is available.	
Protective measures during maintenance of contaminated equipment:	No data available.	
<b>SECTION 9. PHYSICAL AND CHEMICAL PROPERTIES</b>		
Odor		Slight odor
Appearance		Light brown buttery
Boiling point	°C	No Data Available
Solubility		Insoluble in water
Density	@15°C, g/cm <sup>3</sup>	No data available
Dropping point	°C	186
Penetration worked	@25°C, 60W	359
DMSO Extract (Base oil)	Mass % (IP 346)	< 3

<b>SECTION 10. STABILITY AND REACTIVITY</b>	
Stability:	Stable
Condition to Avoid:	See the Handling and Storage section for further details.
Incompatibility (materials to avoid):	Acids. Oxidizing agents. Halogens and halogenated compounds.
Hazardous Polymerization:	Will not occur.
Thermal decomposition:	Smoke, carbon monoxide, aldehydes and other products of incomplete combustion. Hydrogen sulfide and alkyl mercaptans and sulfides may also be released. Under combustion conditions, oxides of the following elements will be formed: Calcium, Sulfur, Zinc.
<b>SECTION 11. TOXICOLOGICAL INFORMATION</b>	
Acute Oral:	No Data Available Believed to be greater than 5/kg (rat) Practically non-toxic
Dermal:	No Data Available Believed to be greater than 3 g/kg (rabbit) Practically non-toxic
Carcinogen:	OSHA This material is listed as Group 3 by IARC (Base oil) EU The classification as a carcinogen need not apply.
<b>SECTION 12. ECOLOGICAL INFORMATION</b>	
Biodegradation:	No Data Available
Environmental fate:	This material is not expected to present any environmental problems other than those associated with oil spills.
<b>SECTION 13. DISPOSAL CONSIDERATIONS</b>	
Waste Disposal Method: Place contaminated materials in disposable containers and dispose of in a manner consistent with applicable regulations. Contact local environmental or health authorities for approved disposal of this material.	
<b>SECTION 14. TRANSPORT INFORMATION</b>	
The description shown may not apply to all shipping situations. DOT Proper Shipping Name: Not applicable IMDG Proper Shipping Name: Not applicable ICAO Proper Shipping Name: Not applicable TDG Proper Shipping Name: Not applicable NFPA Proper name: Class 1. UN Number: Not applicable	

SECTION 15. REGULATION INFORMATION

- The U.S. TSCA inventory: All components of this material are on the US TSCA inventory.  
May require notification before sale in US.  
No data available.
- The EC EINECS inventory: All components of this material are on the EC EINECS inventory.  
May require notification before sale in EC.  
No data available.  
Some components of this material is on the EC ELINCS inventory.  
The other components are on the EC EINECS inventory.
- The CANADA DSL inventory: All components of this material are on the DSL inventory.  
May require notification before sale in CANADA.  
No data available.
- The AUSTRALIA AICS inventory: All components of this material are on the AICS inventory.  
May require notification before sale in AUSTRALIA.  
No data available.
- The KOREA TCCL inventory: All components of this material are on the TCCL inventory.  
May require notification before sale in KOREA.  
No data available.
- The PHILIPPINE PICCS inventory: All components of this material are on the PICCS inventory.  
May require notification before sale in PHILIPPINE.  
No Data Available.

SECTION 16 OTHER INFORMATION

None

References:

3. Handbook of Toxic and Hazardous Chemicals and Carcinogens (2<sup>nd</sup>. ed.)
4. Registry of Toxic Effects of Chemical Substances (HIOSH, 1983)

Material safety data sheets are provided as reference information on the safe handling of hazardous or harmful materials to companies using such materials. When referring to this data sheet, companies should remember that they must take responsibility for implementing the proper measures for their own particular situations. This data sheet is not a guarantee of safety.

## 9.0 Warranty

All products sold by Harrington Hoists, Inc. are warranted to be free from defects in material and workmanship from date of shipment by Harrington for the following periods:

**Manual Hoists & Trolleys - 2 years**

**Air and Electric Powered Hoists, Trolleys, and Crane Components - 1 year**

**Spare / Replacement Parts - 1 year**

The product must be used in accordance with manufacturer's recommendations and must not have been subject to abuse, lack of maintenance, misuse, negligence, or unauthorized repairs or alterations.

Should any defect in material or workmanship occur during the above time period in any product, as determined by Harrington Hoist's inspection of the product, Harrington Hoists, Inc. agrees, at its discretion, either to replace (not including installation) or repair the part or product free of charge and deliver said item F.O.B. Harrington Hoists, Inc. place of business to customer.

Customer must obtain a Return Goods Authorization as directed by Harrington or Harrington's published repair center prior to shipping product for warranty evaluation. An explanation of the complaint must accompany the product. Product must be returned freight prepaid. Upon repair, the product will be covered for the remainder of the original warranty period. If it is determined there is no defect, or that the defect resulted from causes not within the scope of Harrington's warranty, the customer will be responsible for the costs of returning the product.

Harrington Hoists, Inc. disclaims any and all other warranties of any kind expressed or implied as to the product's merchantability or fitness for a particular application. Harrington will not be liable for death, injuries to persons or property or for incidental, contingent, special or consequential damages, loss or expense arising in connection with the use or inability whatever, regardless of whether damage, loss or expense results from any act or failure to act by Harrington, whether negligent or willful, or from any other reason.

**This Page Intentionally Left Blank**

## 10.0 Parts List

When ordering Parts, please provide the Hoist code number, lot number and serial number located on the Hoist nameplate (see fig. below).

Reminder: Per sections 1.1 and 3.6.4 to aid in ordering Parts and Product Support, record the Hoist code number, lot number and serial number in the space provided on the cover of this manual.

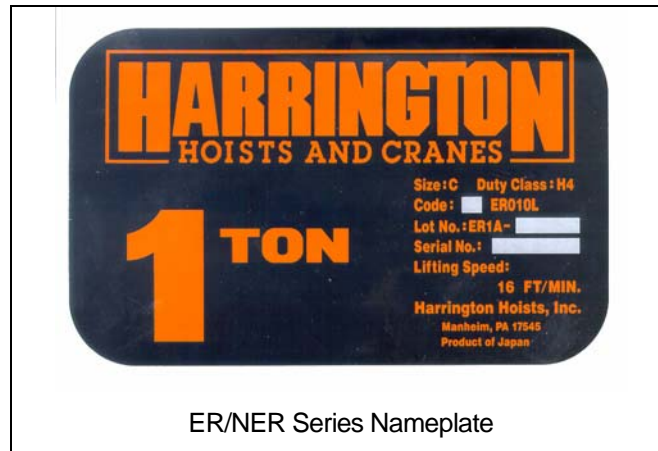

The parts list is arranged into the following sections:

Section	Page
10.1 Housing and Motor Parts.....	54
10.2 Gearing Parts.....	58
10.3 Hook Parts.....	62
10.4 Chaining Parts.....	66
10.5 Electric Parts.....	68
10.6 Power Supply and Pendant Parts.....	70

In the column "Parts Per Hoist" a designator is used for parts that apply only to a particular model or option. Refer to [Section 2](#) for hoist model numbers and additional descriptions. The designators are:

- S = Single Speed
- D = Dual Speed
- F = NER models
- M = ER models
- U = Upper Limit Switch only (standard)
- U/L = Upper/Lower Limit Switch (optional)

## 10.1 Housing and Motor Parts

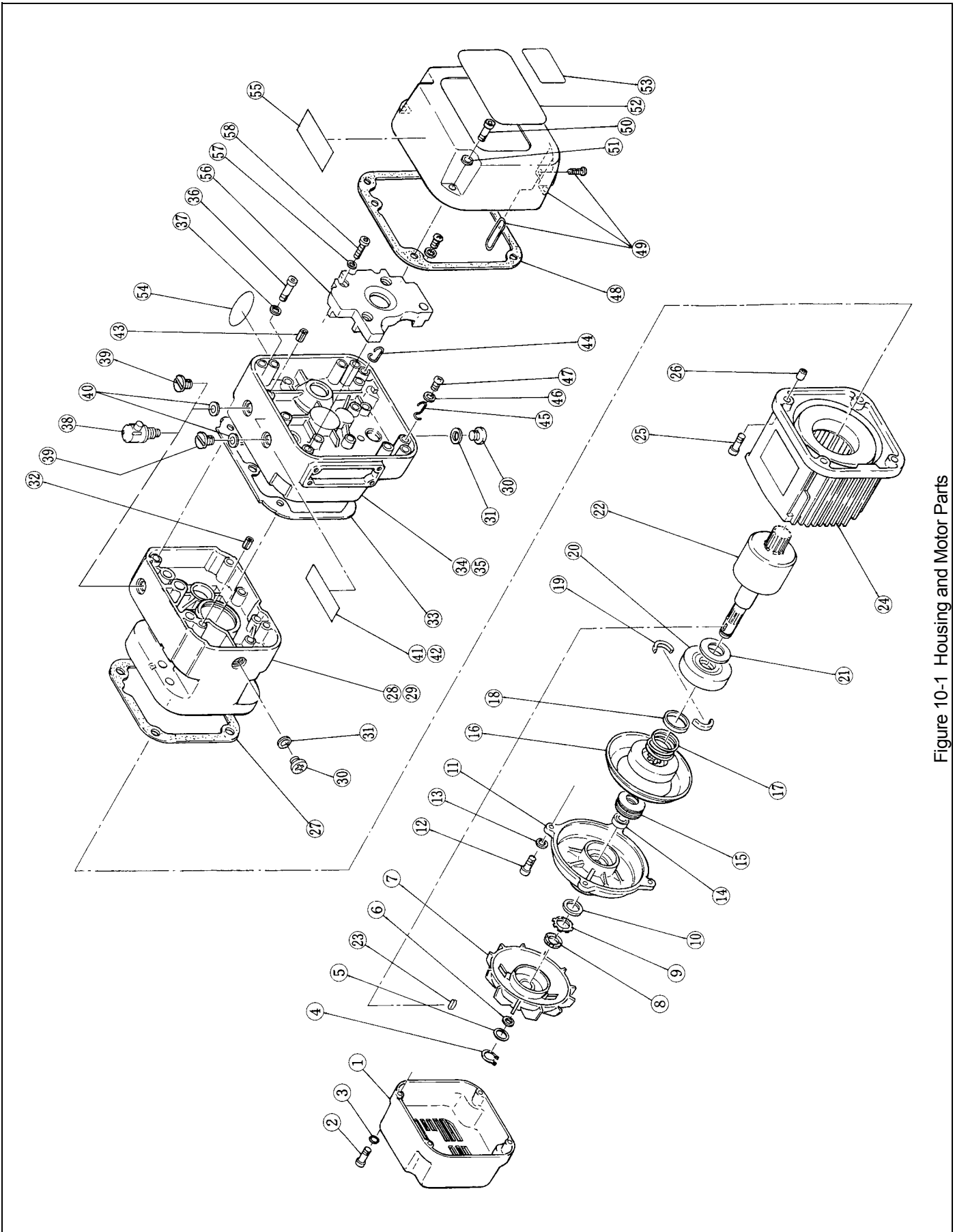

Figure 10-1 Housing and Motor Parts

## 10.1 Housing and Motor Parts

Figure No.	Part Name	Parts Per Hoist	001H	003S	005L	003H	005S	010L	010M	010S	015S	020L	020M	030C	020S	025S	030L	030S	050L
1	Fan Cover	S 1	ER1BS9107		ER1CS9107						ER1DS9107				ER1ES9107				
		D 1	ER1BS9107	ER1CS9107							ER1DS9107					ER1EB9107			
2	Socket Bolt	4		9091233							9091255				9091279				
3	Toothed Lock Washer	4		9679708							9679709				9679711				
4	Snap Ring	1		9047115							9047118				9047124				
5	Fan Washer	1		ER1BS9322							ER1DS9322				ER1ES9322				
6	O Ring	1		9013310							9013314				9013318				
7	Fan	1	ER1BS9108		ER1CS9108						ER1DS9108				ER1ES9108				
8	Nut	1		ES217005S							ES217010S				ES217015				
9	Lock Washer	1		ES218005S							ES218010S				ES218015				
10	Spacer	1		ES216S005							ES216S010				ES216S015				
11	Motor Cover Assembly	S 1	ER1BS2106		ER1CS2106						ER1DS2106				ER1ES2106				
		D 1	ER1BS2106	ER1CS2106							ER1DS2106					ER1EB2106			
12	Socket Bolt	4	9091251		9091273						9091295				90912115				
13	Spring Washer	4	9012709		9012711						9012712				9012713				
14	Collar M	1		ES192005S							ES192010S				ES192015				
15	Coned Disc Spring M	4		E3S191005S							ES191010S				ES191015				
16	Brake Drum Assembly	S 1	ER1BS5212		ER1CS5212						ER1DS5212				ER1ES5212				
		D 1	ER1BS5212	ER1CS5212							ER1DS5212					ER1EB5212			
17	Brake Spring	S 1	ES214003		ES214005S			ER1CE-9214			ES214010S		ER1DE9214		ES214015				
		D 1	ER1BB9214		ER1CB9214						ER1DB9214				ES214D015	ER1FB-9214	ES214-D015		
18	Thrust Collar	S 1	ES506003		ES506005S						ES506010S				ES506015				
		D 1	ES506003				ES506005S				ES506005S				ES506015				
19	Thrust Disc	S 2	ES505003		ES505005S						ES505010S				ES505015				
		D 2	ES505003				ES505005S				ES505005S				ES505015				
20	Pull Rotor	S 1	ES503003		ES503005S						ES503010S				ES503015				
		D 1	ES503003				ES503005S				ES503015				ES503015				
21	Coned Disc Spring	S 1	ES504003		ES504005S						ES504010S				ES504015				
		D 1	ES504003				ES504005S				ES504015				ES504015				
22	Motor Shaft with Rotor	S 1	ER1BS5502		ER1CS5502			ER1CB-5502			ER1DS5502		ER1DE5502		ER1ES5502			ER1FS-5502	ER1ES-5502
		D 1	ER1BB5502		ER1CB5502						ER1DB5502				ER1EB5502			ER1FB-5502	ER1EB-5502
23	Key	1		ER1BS9320										ER1DS9320					

## 10.1 Housing and Motor Parts

Figure No.	Part Name	Parts Per Hoist	001H	003S	005L	003H	005S	010L	010M	010S	015S	020L	020M	030C	020S	025S	030L	030S	050L	
24	Motor Frame with Stator 208-230/460V-3-60	S	1	A1KHM03S5A1	A1KHM05S5A1	A1KHM10E5A1	A1KHM10S5A1	A1KHM10S5A1	A1KHM20E5A1	A1KHM20S5A1	A1KHM20S5A1	A1KHM20S5A1	A1KHM20S5A1	A1KHM20S5A1	A1KHM20S5A1	A1KHM20S5A1	A1KHM20S5A1	A1KHM20S5A1	A1KHM20S5A1	
		D	1	A1KHM03B5A1	A1KHM05B5A1	A1CKK10E5A1	A1KHA10S5A1	A1KHA10S5A1	A1CKK20E5A1	A1KHA20S5A1	A1KHA20S5A1	A1KHA20S5A1	A1KHA20S5A1	A1KHA20S5A1	A1KHA20S5A1	A1KHA20S5A1	A1KHA20S5A1	A1KHA20S5A1	A1KHA20S5A1	
	Motor Frame with Stator 575V-3-60	S	1	A1KHA03S5A1	A1KHA05S5A1		A1KHA10S5A1	A1KHA10S5A1												
		D	1	A1KHA03B5A1	A1KHA05B5A1		A1KHA10B5A1	A1KHA10B5A1												
25	Socket Bolt	4	90912138	9091275		9091297											90912137			
26	Set Pin S	2	ES120003	ES120010S		ER1DS9138											ER1ES9138			
27	Packing M	1	ER1BS9118	ER1CS9118		ER1DS9118											ER1ES9118			
28	Body B	F	1	ER1BS9101	ER1CS9101		ER1DS9101										ER1ES9101			
29	Body C	M	1	ER1BS9099	ER1CS9099		ER1DS9099										ER1ES9099			
30	Oil Plug	2					E3S111003													
31	Plug Packing	2					E3S112003													
32	Set Pin S	2		ES120003			ES120010S										ES120010S			
33	Packing G	1	ER1BS9116	ER1CS9116		ER1DS9116											ER1ES9116			
34	Gear Case M	M	1	ER1BS9102	ER1CS9102		ER1DS9102										ER1ES9102			
35	Gear Case F	F	1	ER1BS9103	ER1CS9103		ER1DS9103										ER1ES9103			
36	Socket Bolt		4	9091259			9091286										90912135			
			5																	
37	Toothed Lock Washer		4	9679709			9679711													
			5																	
38	Oil Cap Assembly	M	1	ER1BS1175	ER1BS1175		ER1BS1175										ER1BS1175			
39	Oil Plug B		2		ER1BS9135															
			3																	
			2																	
40	Eyebolt Packing		1		ES127005S															
41	Name Plate OF	F	1		ER1BS9890															
42	Name Plate OM	M	1	ER1BS9891	ER1BS9891		ER1BS9891										ER1BS9891			
43	Spring Pin		1		E3S129005S															
44	Cover Suspender A		1		ER1BS9431															
45	Cover Suspender B		1		ER1BS9432															
46	Washer		2		ER1BS9436															
47	Machine Screw with Lock Washer		2		E3S650005S															

## 10.1 Housing and Motor Parts

Figure No.	Part Name	Parts Per Hoist	001H	003S	005L	003H	005S	010L	010M	010S	015S	020L	020M	030C	020S	025S	030L	030S	050L
48	Packing C	1	ER1BS9117	ER1CS9117	ER1CS9117						ER1DS9117					ER1ES9117			
49	Controller Cover Assembly	S	ER1BS2104	ER1CS2104	ER1CS2104		ER1CB-2104		ER1CB-2104	ER1DS2104	ER1DS2104	ER1DB2104	ER1DB2104	ER1ES1104		ER1ES1104			
		D	ER1BB2104	ER1CB2104	ER1CB2104						ER1DB2104				ER1ES1104				
50	Socket Bolt	4				9091233						9091254				9091276			
51	Toothed Lock Washer	S				9679708						9679709				9679711			
		D														9679711			
52	Spring Washer	D				9012708					9012709								
		S	A1CHM-03S9A3	A1CHM-05L9A3	A1CHM-05S9A3	A1CHM-10L9A3	A1CHM-10E9A3	A1CHM-10S9A3	A1CHM-15M9A3	A1CHM-20L9A3	A1CHM-20E9A3	A1CHM-30R9A3	A1CHM-20S9A3	A1CHM-25M9A3	A1CHM-30L9A3	A1CHM-30S9A3	A1CHM-50U9A3		
	Name Plate B	D	A1CHM-03B9A3	A1CHM-05B9A3	A1CHM-05B9A3														
		S	A1CHM-03S9A5	A1CHM-05S9A5	A1CHM-05S9A5														
53	Name Plate B Blank	D	A1CHM-03S9A5	A1CHM-03S9A5	A1CHM-05S9A5			A1CHM-05S9A5			A1CHM10S9A5							A1CHM20S9A5	
		S	A1CHM-01H9A6	A1CHM-03S9A6	A1CHM-03S9A6														
54	Name Plate AD	D	A1CHM-01H9A6	A1CHM-05L9A6	A1CHM-03S9A6			A1CHM-10C9A6			A1CHM-15P9A6	A1CHM-20C9A6				A1CHM-25P9A6	A1CHM30C9A6	A1CHM-50V9A6	
		S	ER1BH-9868	ER1BS-9868	ER1BL-9868	ER1BH-9868	ER1BS-9868	ER1BL-9868	ER1CE-9868	ER1CE-9868	ER1BS9868	ER1BS9868	ER1BL-9868	ER1DR-9868	ER1BS-9868	ER1BL-9868	ER1BS-9868	ER1BL-9868	ER1BL-9868
55	Warning Label EE	1																	E2D866125
56	Balancer	S																	ER1EB-9109
		D																	ER1EB9109
57	Spring Washer	S																	90127-11
		D																	9012711
58	Socket Bolt	S																	90912-72
		D																	9091272

## 10.2 Gearing Parts

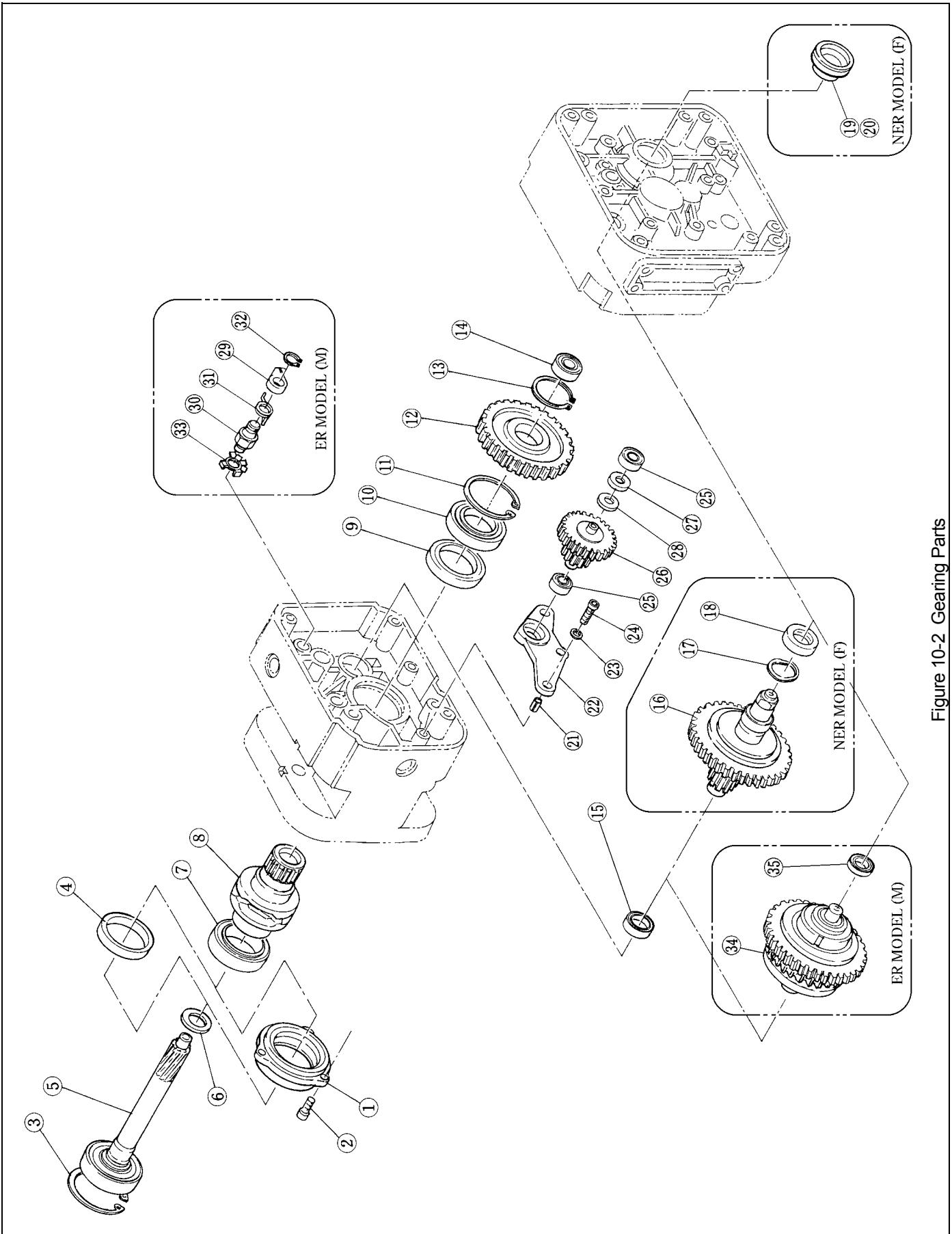

Figure 10-2 Gearing Parts

Figure No.	Part Name	Parts Per Hoist	001H	003S	005L	003H	005S	010L	010M	010S	015S	020L	020M	030C	020S	025S	030L	030S	050L
1	Bearing Holder	1					ER1CS9110				ER1DS9110					ER1ES9110			
2	Socket Bolt	3					90912133				9091250					9091249			
3	Snap Ring	1		9047262			9047262				9047275					9047280			
4	Collar B	1		ER1BS9111															
5	Pinion Assembly	1		ER1BS5220			ER1CS5220				ER1DS5220				ER1ES5220	ER1FS-5220	ER1ES-5220		
6	Oil Seal	1		ES221003					ES221010S							ES221015			
7	Ball Bearing	1		9000507			9000509				9000609					9000611			
8	Load Sheave	1	ER1BS9241	ER1BL-9241		ER1CS9241	ER1CL-9241		ER1DS-9241		ER1DL9241				ER1ES-9241	ER1EM-9241	ER1FS9241		ER1EM-9241
9	Oil Seal	1		ES232005S			ES232005S				ER1DS9244					ES232015			
10	Ball Bearing	1		9000107			9000107				9000109					9000110			
11	Snap Ring	1		9047262			9047262				9047275					9047280			
12	Load Gear	F, S	ER1BH-9240	ER1BS-9240	ER1BL-9240	ER1CH-9240	ER1CS9240	ER1CE-9240	ER1DS-9240	ER1DM-9240	ER1DS-9240	ER1DS-9240	ER1DE9240		ER1ES-9240	ER1EM-9240	ER1EL-9240	ER1FS-9240	ER1EM-9240
		M, S	ER1BH-9240	ER1BS-9240	ER1BA-9240	ER1CH-9240	ER1CS9240			ER1DS-9240	ER1DM-9240	ER1DS-9240			ER1ES-9240	ER1EM-9240	ER1EL-9240	ER1FS-9240	ER1EM-9240
		F, D	ER1BA-9240	ER1BL9240			ER1CS9240			ER1DS-9240	ER1DM-9240	ER1DS-9240			ER1ES-9240	ER1EL9240		ER1FS-9240	ER1EL-9240
		M, D	ER1BA9240	ER1BC-9247			ER1CS9240			ER1DS-9240	ER1DM-9240	ER1DS-9240			ER1ES-9240	ER1EL9240		ER1FS-9240	ER1EL-9240
13	Snap Ring	1		9047130			9047135				9047145					9047150			
14	Ball Bearing	1		9000201			9000301				9000303					9000304			
15	Ball Bearing	1		9000301			9000204				9000404					9000405			
16	Friction Clutch Set	F, S	ER1BH-1223	ER1BS-1223	ER1BL-1223	ER1CH-1223	ER1CS-1223	ER1CL-1223	ER1CE-1223	ER1DS-1223	ER1DM-1223	ER1DL-1223	ER1DE1223		ER1ES-1223	ER1EM-1223	ER1EL-1223	ER1FS-1223	ER1EM-1223
		F, D	ER1BA-1223	ER1BB-1223	ER1BC-1223	ER1CA-1223	ER1CB-1223	ER1CC-1223		ER1DB-1223	ER1DP-1223	ER1DC-1223			ER1EB-1223	ER1EP-1223	ER1EC-1223	ER1FB-1223	ER1EP-1223
17	Wavy Washer	F	1	ER1BS9234			ER1CS9234				ER1DS9234					ER1ES9234			
18	Oil Seal	F	1	ES221005S			E6F235003S				ER1DS9233					ER1ES9233			
19	Friction Plug	F	1	ER1BS9235			ER1CS9235				ER1DS9235					ER1ES9235			
20	Nameplate FP	F	1								ER1BS9892								
21	Set Pin S	F, S	2				ES120003		ES120003			ES120010S				ES120010S			
		M, S	2		ES120-003			ES120-003			ES120010S						ES120010S		
		F, D	2		ES120-003			ES120003		ES120003		ES120010S					ES120010S		
		M, D	2		ES120003			ES120003		ES120003		ES120010S					ES120010S		

## 10.2 Gearing Parts

Figure No.	Part Name	Parts Per Hoist	001H	003S	005L	003H	005S	010L	010M	010S	015S	020L	020M	030C	020S	025S	030L	030S	050L	
22	Gear Plate	F, S	1					ER1CL-9261			ER1DL9261						ER1FS9261			
		M, S	1		ER1BC-9261			ER1CL-9261				ER1DL9261						ER1FS9261		
		F, D	1		ER1BC-9261		ER1CL9261		ER1DL9261									ER1FS9261		
		M, D	1		ER1BC9261		ER1CL9261		ER1DL9261									ER1FS9261		
23	Spring Washer	F, S	3				90127-09	90127-09			9012711						9012711			
		M, S	3		90127-09			90127-09			9012711						9012711			
		F, D	3		90127-09		9012709	9012709			9012711						9012711			
		M, D	3		9012709		9012709	9012709			9012711						9012711			
24	Socket Bolt	F, S	3				90912-138	90912-138			9091275						9091275			
		M, S	3		90912-138			90912-138			9091275						9091275			
		F, D	3		90912-138		90912138	90912138			9091275						9091275			
		M, D	3		90912138		90912138	90912138			9091275						9091275			
25	Ball Bearing (Needle Bearing for 003S and 005L)	F, S	2				9000100	9000100			9000201						9000302			
		M, S	2		ER1BC-9265			9000100			9000201						9000302			
		F, D	2		ER1BC-9265		9000100	9000100			9000201						9000302			
		M, D	2		ER1BC9265		9000100	9000100			9000201						9000302			
26	Gear B Assembly	F, S	1				ER1CL-5262	ER1CL-5262			ER1DM-5262	ER1DL-5262					ER1EL-5262	ER1FS-5262		
		M, S	1			ER1BC5262	ER1CL-5262	ER1CL-5262			ER1DM-5262	ER1DL-5262					ER1EL-5262	ER1FS-5262		
		F, D	1		ER1BC-5262		ER1CL-5262	ER1CL-5262	ER1IC-5262		ER1DL-5262	ER1DP-5262	ER1DC-5262			ER1EL5262	ER1FB-5262	ER1EL-5262		
		M, D	1		ER1BC5262		ER1CL-5262	ER1CL-5262	ER1IC-5262		ER1DL-5262	ER1DP-5262	ER1DC-5262			ER1EL5262	ER1FB-5262	ER1EL-5262		
27	Thrust Needle Bearing	M, S	1		ER1BC-9268															
		F, D	1		ER1BC-9268															
		M, D	1		ER1BC9268															

Figure No.	Part Name	Parts Per Hoist	001H	003S	005L	003H	005S	010L	010M	010S	015S	020L	020M	030C	020S	025S	030L	030S	050L	
28	Thrust Plate	M, S	1		ER1BC-9269															
		F, D	1		ER1BC-9269															
		M, D	1		ER1BC9269															
29	Pawl	M	1		L4155015					L4155015						ES268010S				
30	Pawl Shaft	M	1		ER1BS9289					ER1BS9289						ER1ES9289				
31	Pawl Spring	M	1		ER1BS9290					ER1BS9290						ER1ES9290				
32	Snap Ring	M	1		L4188015					L4188015						9047116				
33	Pawl Shaft Washer	M	1		ER1BS9294					ER1BS9294						ER1ES9294				
34	Mechanical Brake with Friction Clutch Set	M, S	1	ER1BH-1274	ER1BS-1274	ER1BL-1274	ER1CH-1274	ER1CL-1274		ER1DS-1274	ER1DM-1274	ER1DL-1274			ER1ES-1274	ER1EM-1274	ER1EL-1274	ER1FS-1274	ER1EM-1274	
		M, D	1	ER1BA-1274	ER1BB-1274	ER1BC-1274	ER1CA-1274	ER1CB-1274	ER1CC-1274		ER1DB-1274	ER1DP-1274	ER1DC-1274			ER1EB-1274	ER1EP-1274	ER1EC-1274	ER1FB-1274	ER1EP-1274
35	Ball Bearing	M	1		9000201						9000303						9000304			

### 10.3 Hook Parts

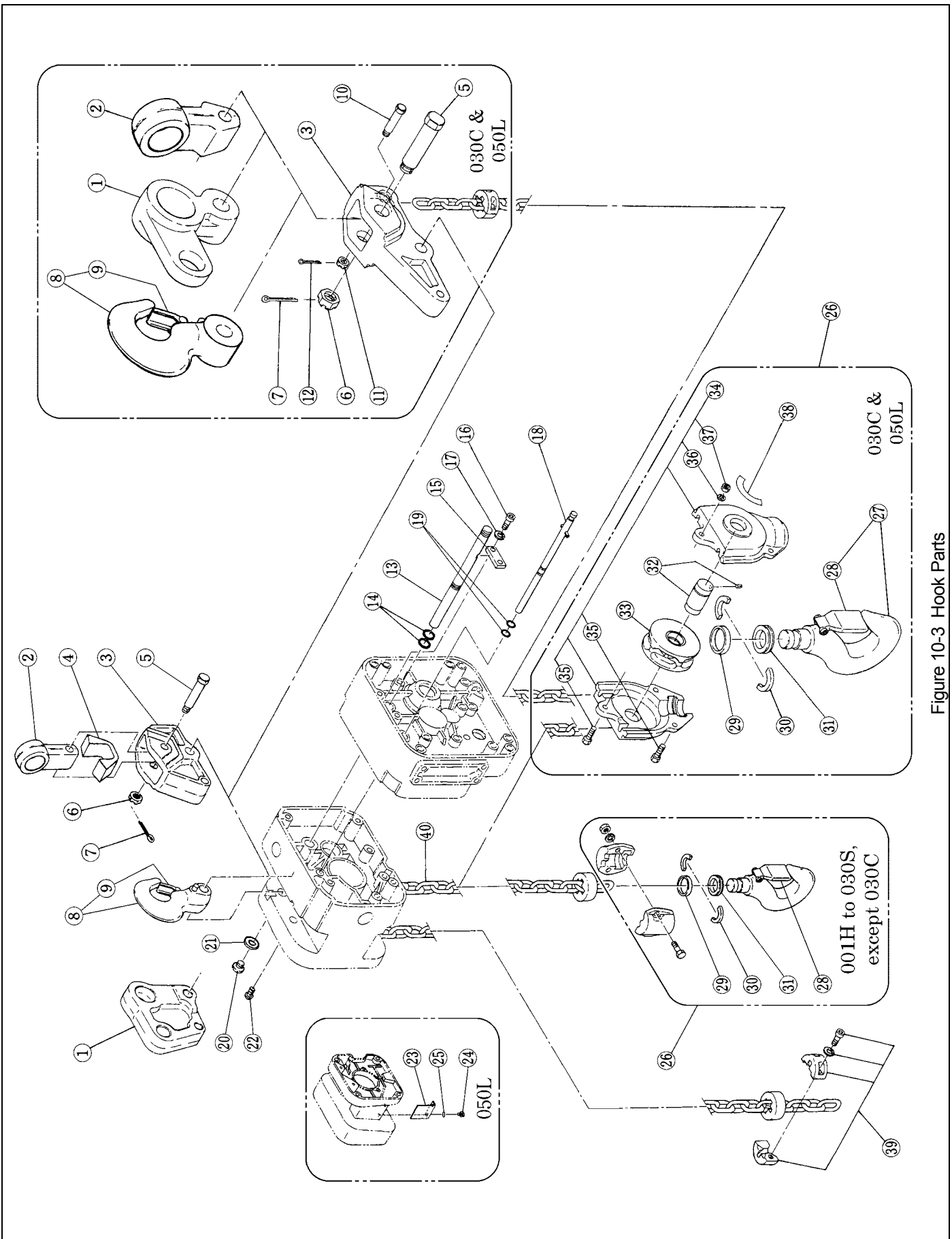

Figure 10-3 Hook Parts

### 10.3 Hook Parts

Figure No.	Part Name	Parts Per Hoist	001H	003S	005L	003H	005S	010L	010M	010S	015S	020L	020M	030C	020S	025S	030L	030S	050L
1	Suspender T (for MR Motorized Trolley)	1	ER1BS9031	ER1CS9031						ER1DS-9031	ER1DL9031			ER1DR-9031	ER1ES-9031	ER1FS9031			ER1FR-9031
2	Suspender G (for Motorized Trolley)	1		MR1DS9001							MR1ES9001			MR1FS-9001	MR1ES-9001	MR1FS9001			MR1GS-9001
	Suspender E (for Geared Trolley)	1		T7GB004010							T7GB004020			T7GB-004030	T7GB-004020	T7GB004030			MR1GS-9001
	Suspender E (for Push Trolley)	1		T7GB004005				T7GB004010			T7GB004020			T7GB-004030	T7GB-004020	T7GB004030			MR1GS-9001
3	Connection Yoke	1	ER1BS9029	ER1CS9029						ER1DS-9029	ER1DL9029			ER1DR-9030	ER1ES-9028	ER1ES9029			ER1FR-9030
4	Connection Yoke Rubber	1		ER1BS9028							ER1DL9028				ER1ES-9028	ER1FS9028			
5	Yoke Bolt	1		ER1CS9032										ER1ES9032					ES006-050
6	Slotted Nut	1		L3183008										ES088020L					ES088-050
7	Split Pin	1		90094145										9009436					90094-37
8	Top Hook Assembly	1	ER1BS1001	ER1BL-1001	ER1CS1001	ER1CL1001	ER1CS1001	ER1CL1001	ER1DS-1001	ER1DS-1001	ER1DL1001			ER1DR-1001	ER1ES-1001	ER1FS1001			ER1FR-1001
9	Hook Latch Assembly	1		ER1BS1002				ER1DS1002			ER1ES1002			ER1FS-1002	ER1ES-1002	ER1FS1002			ER1FR-1002
10	Chain Pin	1												ES041-030					ES041-050
11	Slotted Nut	1												M2049-020					M2049-030
12	Split Pin	1												90094-13					90094-145
13	Connection Shaft	1	ER1BS9121	ER1CS9121				ER1DS9121			ER1DS9121								ER1ES9121
14	O Ring	2	9013306	9013309							9013313								9013317
15	Plate A	1		ER1BS9123							ER1DS9123								ER1ES9123
16	Machine Screw with Spring Washer	2		M6F554010															
	Socket Bolt	2																	9091249
17	Toothed Lock Washer	2																	9012709
18	Fixing Shaft Assembly	1	ER1BS1122	ER1CS1122				ER1DS1122			ER1DS1122								ER1ES1122
19	O Ring	2		9013305							9013307								
20	Shaft Plug	1	ER1BS9128	ER1CS9128				ER1DS9128			ER1DS9128								
	Oil Plug	1																	E7S126005
21	Plug Packing	1																	ES127005S
22	Machine Screw	1																	9798543

### 10.3 Hook Parts

Fig No	Part Name	Parts Per Hoist	001H	003S	005L	003H	005S	010L	010M	010S	015S	020L	020M	030C	020S	025S	030L	030S	050L
23	Body Protector	1																	ER1FR-9055
24	Socket Bolt	2																	90912-72
25	Spring Washer	2																	90127-11
26	Bottom Hook Complete Set	1	ER1BH-1011	ER1BS-1011	ER1CS-1011	ER1CH-1011	ER1CS-1011	ER1DS1011	ER1DM-1011	ER1ES1011	ER1DR-1011	ER1ES-1011	ER1EM-1011	ER1FS1011	ER1FR-1011				
27	Bottom Hook Assembly	1												ER1FS-2011					ER1FR-2011
28	Hook Latch Assembly	1		ER1BS1002				ER1DS1002	ER1DM-1002	ER1ES1002	ER1FS1002	ER1ES-1002	ER1FS1002	ER1FR-1002					
29	Thrust Collar A	1		ES026003				ES026010L	ES026015	ES026015	ES026-025	ES026-015	ES026-025	ES026-050					
30	Hook Stopper	2		ES027003				ES027010L	ES027015	ES027015	ES027-025	ES027-015	ES027-025	ES027-050					
31	Thrust Bearing	1		ES022003				ES022010L	ES022015	ES022015	ES022-025	ES022-015	ES022-025	ES022-050					
32	Bottom Shaft Assembly	1												ES5054-030					ES5054-050
33	Idle Sheave Assembly	1												ES1051-030					ES1051-050
34	Bottom Yoke Assembly	1												ES032-030					ES032-050
35	Bolt	3												ES082-025					ES082-050
36	Spring Washer	3												90127-12					90127-13
37	Nut	3												90934-27					90934-25
38	Name Plate C	1												M3805-030					M3805-030
39	Stopper Assembly	1		ER1CS1041				ER1DS1041	ER1ES1041	ER1ES1041				ER1ES1041					ER1ES1041
		2												ER1ES1041					ER1ES1041
40	Load Chain (Black)	1	LCER003C	LCER005C				LCER010C	LCER020C	LCER030C				LCER-025C					LCER-025C
	Load Chain (Nickel Plated)	1	LCER003NP	LCER005NP				LCER010NP	LCER020NP	LCER030NP				LCER-025NP					LCER-025NP
	Load Chain (Nickel Diffused)	1	LCER003ND	LCER005ND				LCER010ND	LCER020ND	LCER030ND				LCER-025ND					LCER-025ND

This Page Intentionally Left Blank

# 10.4 Chaining Parts

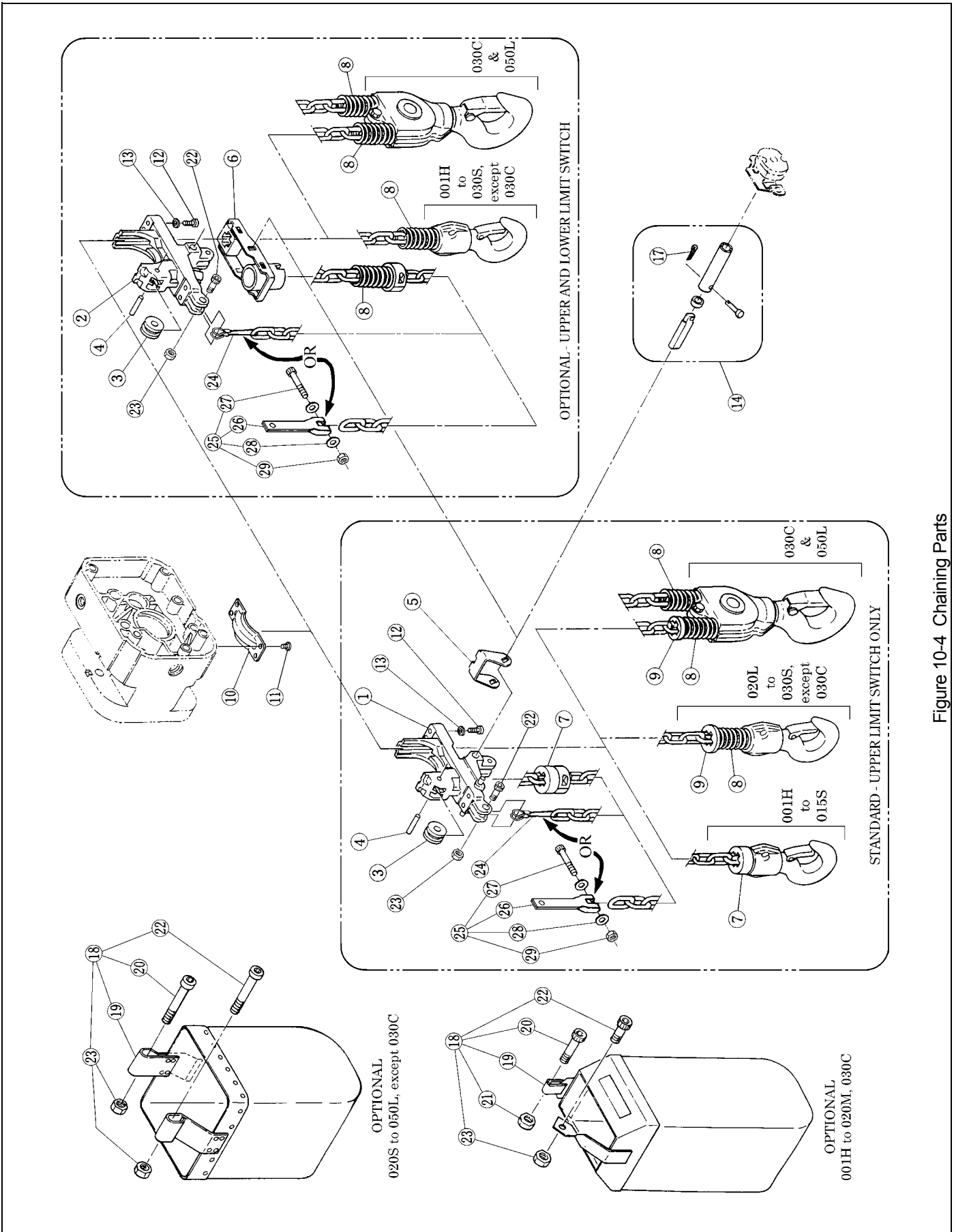

Figure 10-4 Chaining Parts

## 10.4 Chaining Parts

Fig No	Part Name	Parts Per Hoist	001H	003S	005L	003H	005S	010L	010M	010S	015S	020L	020M	030C	020S	025S	030L	030S	050L	
1	Chain Guide A	U	1	ER1BS9331	ER1BL-9331	ER1CS1331	ER1CL1331	ER1CL1331	ER1CL1331	ER1DS-1331		ER1DL1331			ER1ES-9331	ER1EM-9331	ER1FS9331	ER1FS9331	ER1EM-9331	
2	Chain Guide AL	U/L	1	ER1BS9330	ER1BL-9330	ER1CS9330	ER1CL9330	ER1CL9330	ER1CL9330	ER1DS-9330		ER1DL9330			ER1ES-9330	ER1EM-9330	ER1FS9330	ER1FS9330	ER1EM-9330	
3	Guide Roller	1				ES403005S	ER1DS9333	ER1DS9333	ER1DS9333	ER1DS-9333		ER1DL9333				ER1EM-9333	ER1FS9333	ER1FS9333	ER1EM-9333	
4	Roller Pin	1				ER1CS9334	ER1CS9334	ER1CS9334	ER1CS9334	ER1DS-9334		ER1DL9334					ER1ES9334			
5	Limit Lever S	U	1	ER1BS9337		ER1CS9337	ER1CS9337	ER1CS9337	ER1CS9337	ER1DS-9337		ER1DS9337			ER1ES-9337	ER1EM-9337	ER1FS9337	ER1FS9337	ER1EM-9337	
6	Limit Lever Assembly	U/L	1	ER1BS5335	ER1BL-L5335	ER1CS5335	ER1CL5335	ER1CL5335	ER1CL5335	ER1DS-5335		ER1DL5335			ER1ES-5335	ER1EM-5335	ER1FS5335	ER1FS5335	ER1EM-5335	
7	Cushion Rubber	U	(x)	ER1BS9053 (2)	ER1BL-9053 (2)	ER1CS9053 (2)	ER1CL9053 (2)	ER1CL9053 (2)	ER1CL9053 (2)	ER1DS-9053 (2)		ER1DL9053 (2)		ER1ES9053 (1)		ER1EM-9053 (1)	ER1FS9053 (1)	ER1FS9053 (1)	ER1EM-9053 (1)	
8	Chain Spring	U, S	(x)									ER1DL9051 (1)	ER1DL-9051 (2)	ER1DL-9051 (2)	ES047-015 (1)	ER1EM-9051 (1)	ER1FS9051 (1)	ER1FS9051 (1)	ER1EM-9051 (2)	
		U, D	(x)									ES047-015 (1)			ES047-D015 (1)	ER1FH-9051 (1)	ER1FB9051 (1)	ER1FB9051 (1)	ER1FH-9051 (2)	
		U/L, S	(x)	ES047D003 (2)	ES047A005 (2)	ER1DS9051 (2)	ER1DS9051 (2)	ER1DS9051 (2)	ER1DS9051 (2)	ER1DS9051 (2)	ER1DS-9051 (2)		ER1DL9051 (2)	ER1DL-9051 (3)	ER1DL-9051 (2)	ES047-015 (2)	ER1EM-9051 (2)	ER1FS9051 (2)	ER1FS9051 (2)	ER1EM-9051 (3)
		U/L, D	(x)	ES047-D003 (6)	ES047A005 (2)	ER1DS-9051 (2)	ER1DS-9051 (2)	ER1DS-9051 (2)	ER1DS-9051 (2)	ER1DS-9051 (2)	ER1DS-9051 (2)		ES047-015 (2)	ER1DL-9051 (2)	ER1DL-9051 (2)	ES047-D015 (2)	ER1FH-9051 (2)	ER1FB9051 (2)	ER1FB9051 (2)	ER1FH-9051 (3)
		U	1												ER1ES9054		ER1FH-9054	ER1FS9054	ER1FS9054	ER1FH-9054
9	Limit Lever Striker	U	1											ER1ES9054		ER1FH-9054	ER1FS9054	ER1FS9054	ER1FH-9054	
10	Chain Guide B	1	1	ER1BS9332	ER1BL-9332	ER1CS9332	ER1CL9332	ER1CL9332	ER1CL9332	ER1DS-9332		ER1DL9332			ER1ES-9332	ER1EM-9332	ER1FS9332	ER1FS9332	ER1EM-9332	
11	Mach. Screw w/Spring Washer	4	4	90912138						M6F554010							E6F151003			
12	Socket Bolt	4	4	90912138			9091254					9091277					9091274			
13	Spring Washer	4	4											9012711						
14	Limit Lever Pin Assembly	1	1	ER1BS1338		ER1CS1338	ER1CS1338	ER1CS1338	ER1CS1338	ER1DS-1338		ER1DS1338					ER1ES1338			
17	Split Pin	1	1									9009410								
18	Chain Container Kit	1	1	BKB1		BKC1	BKD1	BKD1	BKD1											
19	Chain Container Assembly	1	1	ER1BS6403		ER1CS6404	ER1CS6405	ER1CS6405	ER1CS6405								BKE2			
20	Socket Bolt	1	1			ER419001		ER419001	ER419001								90912104			
21	Lever Nut	1	1			ES855003		ES855003	ES855003											
22	Socket Bolt	1	1			ER414001		ER414001	ER414001								90912136			
23	Lever Nut	1	1			ES857005S		ES857005S	ES857005S											
24	End Wire (OBSOLETE) *	1	1			ER1BS9408		ER1BS9408	ER1BS9408					ER1DS9408			L4082060			
25	End Suspender Assembly	1	1	ENDSUB		ENDSUSCD	ENDSUSCD	ENDSUSCD	ENDSUSCD					END-SUSDR			ENDSUSE			
26	End Suspender	1	1			ER1BS9408R2		ER1BS9408R2	ER1BS9408R2					ER1DR-9408			ER1ES9408			
27	Socket Bolt	1	1	9091255				ER414001	ER414001					J1BE080-3518			J1BE11006032			
28	Flat Washer	2	2	J1WD01100060																
29	Lever Nut	1	1	ES855003		ES857005S		ES857005S	ES857005S								L4082060			

\* Replace figure #24 with figure #25 End Suspender Assembly.

## 10.5 Electric Parts

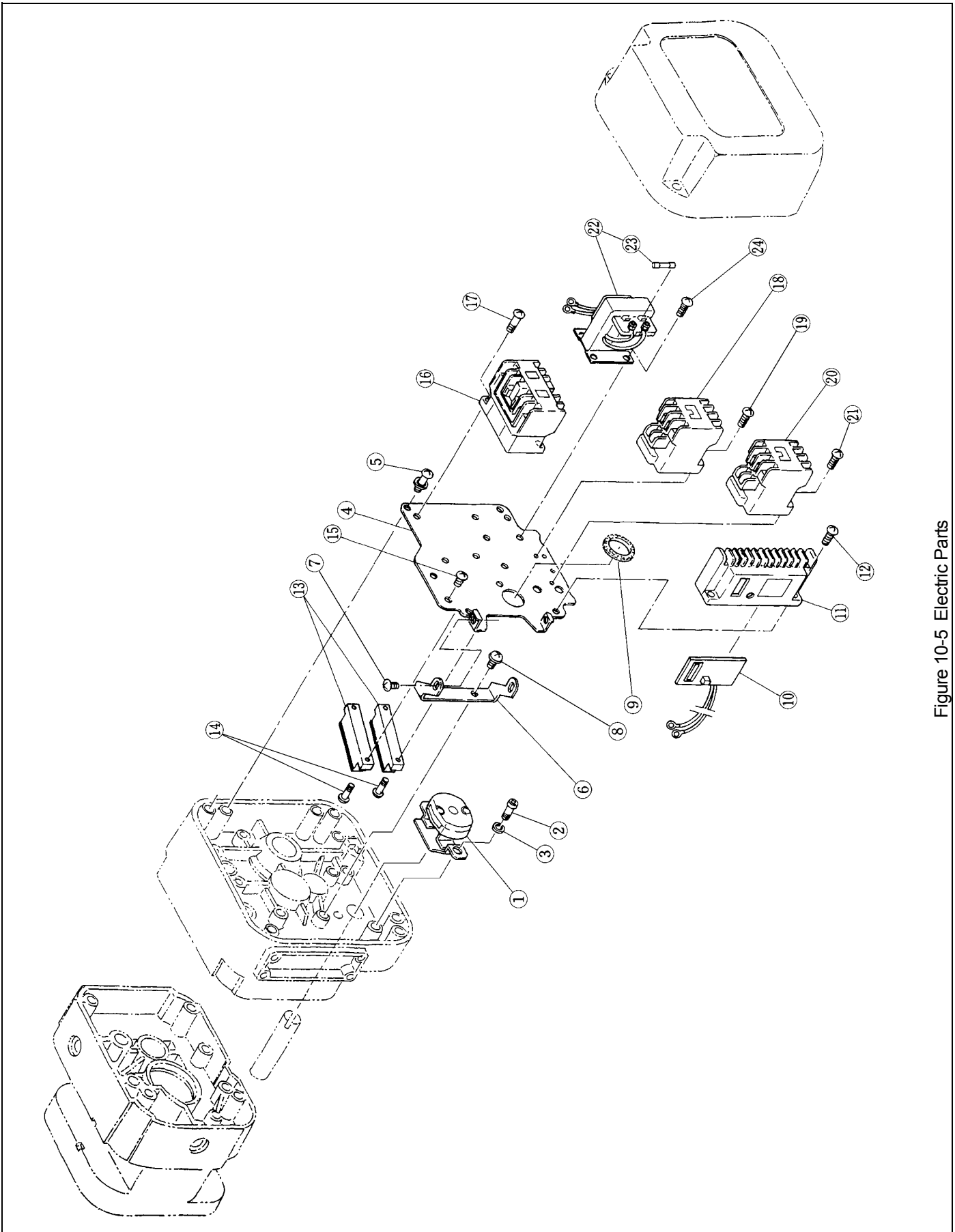

Figure 10-5 Electric Parts

10.5 Electric Parts

Fig No	Part Name	Parts Per Hoist	001H	003S	005L	003H	005S	010L	010M	010S	015S	020L	020M	030C	020S	025S	030L	030S	050L
1	Limit Switch Assembly	U	1					ER1BS1551								ER1ES1551			
		U/L	1					ER1BS2551								ER1ES2551			
2	Socket Bolt		3							9091247									
3	Spring Washer		3							9012709									
4	Plate		1	ER1BB9441			ER1CB9441					ER1DB9441					ER1EB9441		
5	Plate Screw		3				ER1BS9445												
			4																
6	Hinge		1	ER1BS9442			ER1CS9442										ER1BS9445		
7	Hinge Screw		2						ER1BS9443										
8	Mach. Screw w/Spring Washer		2						E6F151003										
9	Bushing		1		ECP99JBAA						ECP99JBAB								
10	CH Meter - Trans. Secondary = 110V	M	1	ECP91CHAB						ECP91CHAB								ECP91CHAB	
11	Terminal Plate, 3P		1						ECP1303AA										
12	Mach. Screw w/Spring Washer		2						MS555010										
13	Terminal Plate 6P	S	1						ECP1306AA										
		D	2	ECP1306AA					ECP1306AA									ECP1306AA	
14	Mach. Screw w/Spring Washer	S	2						MS556010										
		D	4	MS556010					MS556010									MS556010	
15	Mach. Screw w/Spring Washer		3						MS555010										
16	Electromagnetic Contactor		1		MGC22306A					MGC23306A				MGC23306B				MGC2-4306A	MGC2-3306B
17	Mach. Screw w/Spring Washer		2						MS556010										
18	Electromagnetic Contactor - High Speed	D	1		MGC11226A					MGC12226A					MGC13226B			MGC1-5306A	MGC1-3226B
19	Mach. Screw w/Spring Washer	D	2		MS556010					MS556010								MS556010	
20	Electromagnetic Contactor - Low Speed	D	1															MGC1-3306A	
21	Mach. Screw w/Spring Washer	D	2															MS556-010	
22	Transformer - Primary = 208-230/460V - Secondary = 110V	S	1					TRF62M601										TRF63M601	
		D	1		TRF62M601					TRF62M601								TRF65-M601	TRF63-M601
	Transformer - Primary = 575V - Secondary = 110V	S	1					TRF32K601										TRF33K601	
		D	1		TRF32K601					TRF32K601								TRF35-K601	TRF33-K601
23	Fuse - Trans. Secondary = 110V	S	1					9006271									9006272		
		D	1		9006271					9006271						9006272			9006273
24	Mach. Screw w/Spring Washer		4						MS555010										

## 10.6 Power Supply and Pendant Parts

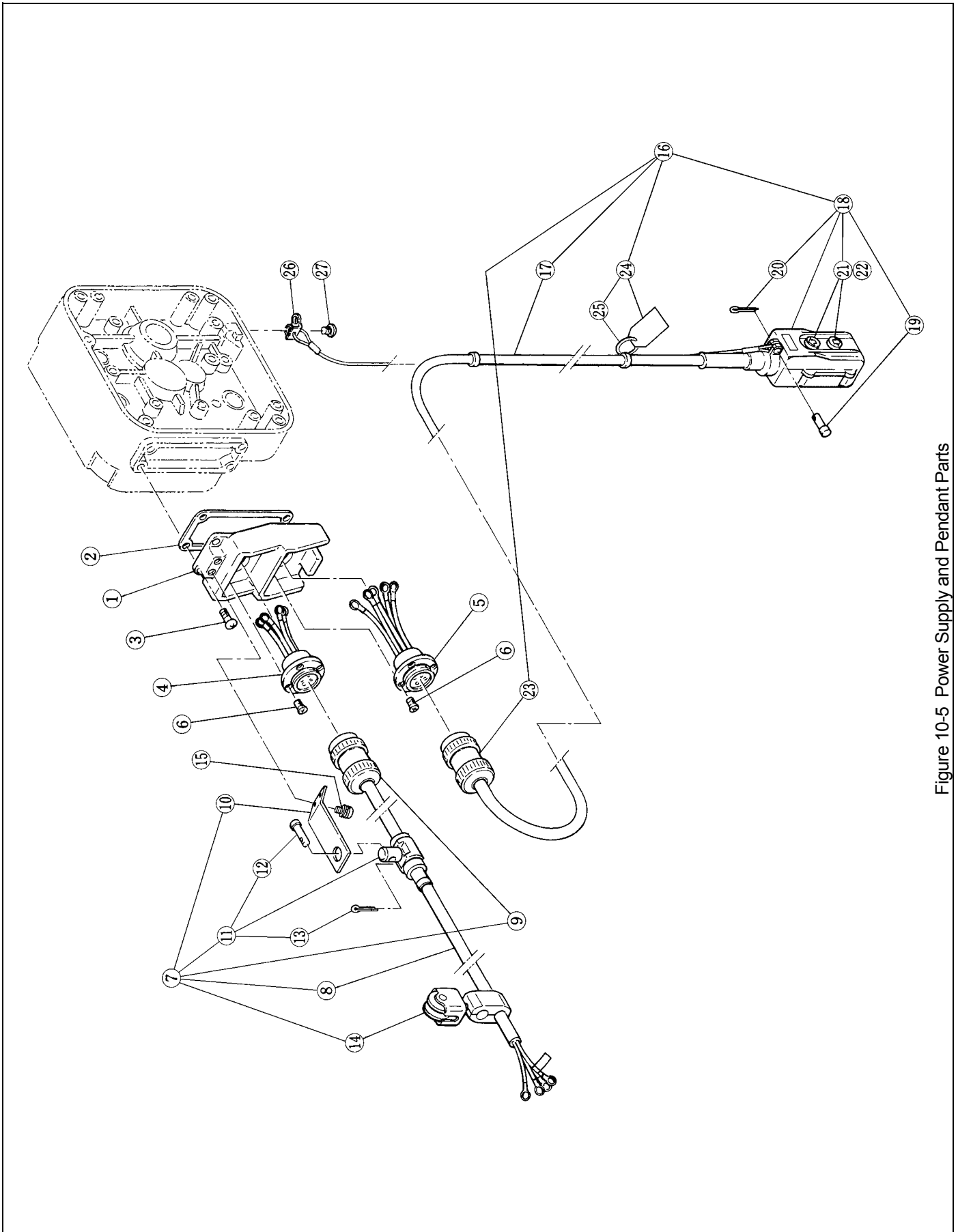

Figure 10-5 Power Supply and Pendant Parts

## 10.6 Power Supply and Pendant Parts

Fig No	Part Name	Parts Per Hoist	001H	003S	005L	003H	005S	010L	010M	010S	015S	020L	020M	030C	020S	025S	030L	030S	050L
1	Socket Holder	1									ER1BS9511								
2	Socket Holder Packing	1									ER1BS9512								
3	Machine Screw with Spring Washer	4									ES656003								
4	Socket 4P Assembly	1						ER1BS1523									ER1ES1523		
5	Socket 5P Assembly	S						ER1BS1564									ER1ES1564		
		D						ER1BB1564									ER1EB1564		
6	Flat Head Tapping Machine Screw	8									ES558003								
7	Power Supply Cable 4C Complete Set	1						ER1BS1521									ER1ES1521		
8	Power Supply Cable 4C	1						14/4									12/4		
9	Plug 4P	1						ES622003									E7S522003		
10	Cable Support Arm	1									ER1BS9541								
11	Cable Support 12 Assembly	1						ES822003									MS1724010		
12	Cord Support Pin B	1									ES628003								
13	Split Pin	1									9009402								
14	Cable Hanger 14 Assembly	2						ES1527003									MS1733020		
15	Machine Screw with Spring Washer	2									ES650005S								
16	Push Button Cord Complete Set	S						ER1BS1557									ER1ES1557		
		D									ER1BB1558						ER1EB1558		
17	Push Button Cord 3C	S									16/3P								
		D									16/4P						16/4P		
18	2 Push Button Switch Assembly	S									ES1615S003								
		D									ECP311BAB						ECP311BAB		
19	Cord Chain Pin B	1									ES628003								
20	Split Pin	1									9009402								
21	Cap	2									CAP								
22	Arrow - set of 2	S									ARROWS								
		D									ARROWD						ARROWD		
23	Plug 5P	1									E3S613003								
24	Warning Tag LD	1									WTAG7								
25	Tag Holder	1									E3S787003								
26	Cord Support Wire Stopper	1									ER1BS9535								
27	Machine Screw with Spring Washer	2									M6F554010								

# **HARRINGTON** HOISTS AND CRANES

[www.harringtonhoists.com](http://www.harringtonhoists.com)

Harrington Hoists, Inc.  
401 West End Avenue  
Manheim, PA 17545-1703  
Phone: 717-665-2000  
Toll Free: 800-233-3010  
Fax: 717-665-2861

Harrington Hoists – Western Division  
2341 Pomona Rd. #103  
Corona, CA 92880-6973  
Phone: 951-279-7100  
Toll Free: 800-317-7111  
Fax: 951-279-7500

**EROM**