

---

# OWNER'S MANUAL

---

## Mini-Cat AIR POWERED CHAIN HOIST AH SERIES

250 and 500 Lb. Capacity

Product Code and Serial Number

### **WARNING**

This equipment should not be installed, operated or maintained by any person who has not read and understood all the contents of this manual. Failure to read and comply with the contents of this manual can result in serious bodily injury or death, and/or property damage.

**HARRINGTON**  
HOISTS AND CRANES

# Table of Contents

<b>Section</b>	<b>Page Number</b>
1.0 Important Information and Warnings .....	4
1.1 Terms and Summary	
1.2 Warning Tags and Labels	
2.0 Technical Information.....	8
2.1 Specifications	
2.2 Speeds, Air Consumptions and Dimensions	
2.3 Part Names	
3.0 Pre-operational Procedures .....	14
3.1 Air Supply System Requirements	
3.2 Air Supply Capacity and Regulation	
3.3 Lubrication	
3.4 Filtration	
3.5 Air Dryer	
3.6 Piping, Hoses and Fittings	
3.7 Mounting Location	
3.8 Connecting Hoist to Air Supply	
3.9 Mounting the Hoist	
3.10 Optional Chain Container	
3.11 Non-Stationary Applications	
3.12 Manipulator Right or Left Hand Operation	
3.13 Manipulator Model's Bottom Hook Position	
3.14 Pre-operational Checks and Trial Operation	
4.0 Operation .....	24
4.1 Introduction	
4.2 Shall's and Shall Not's for Operation	
4.3 Hoist Controls	
4.4 Controlling Hoist Speed	

<b>Section</b>	<b>Page Number</b>
5.0 Inspection .....	28
5.1 General	
5.2 Inspection Classification	
5.3 Frequent Inspection	
5.4 Periodic Inspection	
5.5 Occasionally Used Hoists	
5.6 Inspection Records	
5.7 Inspection Methods and Criteria	
6.0 Lubrication.....	35
6.1 Air Hoist Lubrication	
6.2 Load Chain Lubrication	
6.3 Hooks and Suspension Components	
7.0 Maintenance and Handling .....	36
7.1 Brake	
7.2 Load Chain	
7.3 Pendant and Manipulator	
7.4 Load Sheave Inspection	
7.5 Storage	
7.6 Outdoor Installation	
8.0 Troubleshooting .....	43
9.0 Warranty .....	45
10.0 Parts List .....	47

## 1.0 Important Information and Warnings

### 1.1 Terms and Summary

**This manual provides important information** for personnel involved with the installation, operation and maintenance of this product. Although you may be familiar with this or similar equipment, it is strongly recommended that you read this manual before installing, operating or maintaining the product.

#### Danger, Warning, Caution and Notice

Throughout this manual there are steps and procedures that can present hazardous situations. The following signal words are used to identify the degree or level of hazard seriousness.

**⚠ DANGER** Danger indicates an imminently hazardous situation which, if not avoided, **will** result in **death or serious injury**, and property damage.

**⚠ WARNING** Warning indicates an imminently hazardous situation which, if not avoided, **could** result in **death or serious injury**, and property damage.

**⚠ CAUTION** Caution indicates a potentially hazardous situation which, if not avoided, **may** result **minor or moderate injury** or property damage.

**NOTICE** Notice is used to notify people of installation, operation, or maintenance information which is important but not directly hazard-related.

### ⚠ CAUTION

These general instructions deal with the normal installation, operation, and maintenance situations encountered with the equipment described herein. The instructions should not be interpreted to anticipate every possible contingency or to anticipate the final system, crane, or configuration that uses this equipment. For systems using the equipment covered by this manual the supplier and owner of the system are responsible for the system's compliance with all applicable industry standards, and with all applicable Federal, State, and Local regulations/codes.

This manual includes instructions and parts information for a variety of hoist types. Therefore, all instructions and parts information may not apply to any one type or size of specific hoist. Disregard those portions of the instructions that do not apply.

Record your hoist's Product Code and Serial Number (see Figure 10-1) on the front cover of this manual for identification and future reference to avoid referring to the wrong manual for information or instructions on installation, operation, inspection, maintenance, or parts.

Use only Harrington authorized replacement parts in the service and maintenance of this hoist.

## **WARNING**

Equipment described herein is not designed for and **MUST NOT** be used for lifting, supporting, or transporting people, or for lifting or supporting loads over people.

Equipment described herein should not be used in conjunction with other equipment unless necessary and/or required safety devices applicable to the system, crane, or application are installed by the system designer, system manufacturer, crane manufacturer, installer, or user.

Modifications to upgrade, rerate, or otherwise alter this equipment shall be authorized only by the original equipment manufacturer.

Equipment described herein may be used in the design and manufacture of cranes or monorails. Additional equipment or devices may be required for the crane and monorail to comply with applicable crane design and safety standards. The crane designer, crane manufacturer, or user is responsible to furnish these additional items for compliance. Refer to ANSI/ASME B30.17, "Safety Standard for Top-Running Single Girder Cranes"; ANSI/ASME B30.2 "Safety Standard for Top-Running Double-Girder Cranes"; and ANSI/ASME B30.11 "Safety Standard for Underhung Cranes and Monorails".

If a below-the-hook lifting device or sling is used with a hoist, refer to ANSI/ASME B30.9, Safety Standard for Slings, or ANSI/ASME B30.20, Safety Standard for Below-the-Hook Lifting Devices.

Hoists and cranes, used to handle hot molten material may require additional equipment or devices. Refer to ANSI Z241.2, "Safety Requirements for Melting and Pouring of Metals in the Metalcasting Industry".

Failure to read and comply with any one of the limitations noted herein can result in serious bodily injury or death, and/or property damage.

## **WARNING**

**HAZARDOUS AIR PRESSURE IS PRESENT IN THE HOIST, IN THE SUPPLY OF COMPRESSED AIR TO THE HOIST, AND IN THE CONNECTIONS BETWEEN COMPONENTS.**

Before performing ANY maintenance on the equipment, de-energize the supply of compressed air to the equipment, and lock and tag the supply device in the de-energized position. Refer to ANSI Z244.1, "Personnel Protection - Lockout/Tagout of Energy Sources."

Only trained and competent personnel should inspect and repair this equipment.

## NOTICE

It is the responsibility of the owner/user to install, inspect, test, maintain, and operate a hoist in accordance with ANSI/ASME B30.16, "Safety Standard for Overhead Hoists" and OSHA Regulations. If the hoist is installed as part of a total lifting system, such as an overhead crane or monorail, it is also the responsibility of the owner/user to comply with the applicable ANSI/ASME B30 volume that addresses that type of equipment.

It is the responsibility of the owner/user to have all personnel that will install, inspect, test, maintain, and operate a hoist read the contents of this manual and applicable portions of ANSI/ASME B30.16, "Safety Standard for Overhead Hoists", and OSHA Regulations. If the hoist is installed as part of a total lifting system, such as an overhead crane, the applicable ANSI/ASME B30 volume that addresses that type of equipment must also be read by all personnel.

If the hoist owner/user requires additional information, or if any information in the manual is not clear, contact Harrington or the distributor of the hoist. Do not install, inspect, test, maintain, or operate this hoist unless this information is fully understood.

A regular schedule of inspection of the hoist in accordance with the requirements of ANSI/ASME B30.16 should be established and records maintained.

## 1.2 Warning Tags and Labels

The warning tag illustrated below in [Figure 1-1](#) is supplied with each hoist shipped from the factory. If the tag is not attached to your hoist (for pendant and manipulator control, the warning tag is attached to the pendant hose; for the pull cord control, the warning tag is attached to the up cord), order a tag from your dealer and install it. See parts list in the parts section of this manual. Read and obey all warnings attached to this hoist. Tag is not shown actual size.

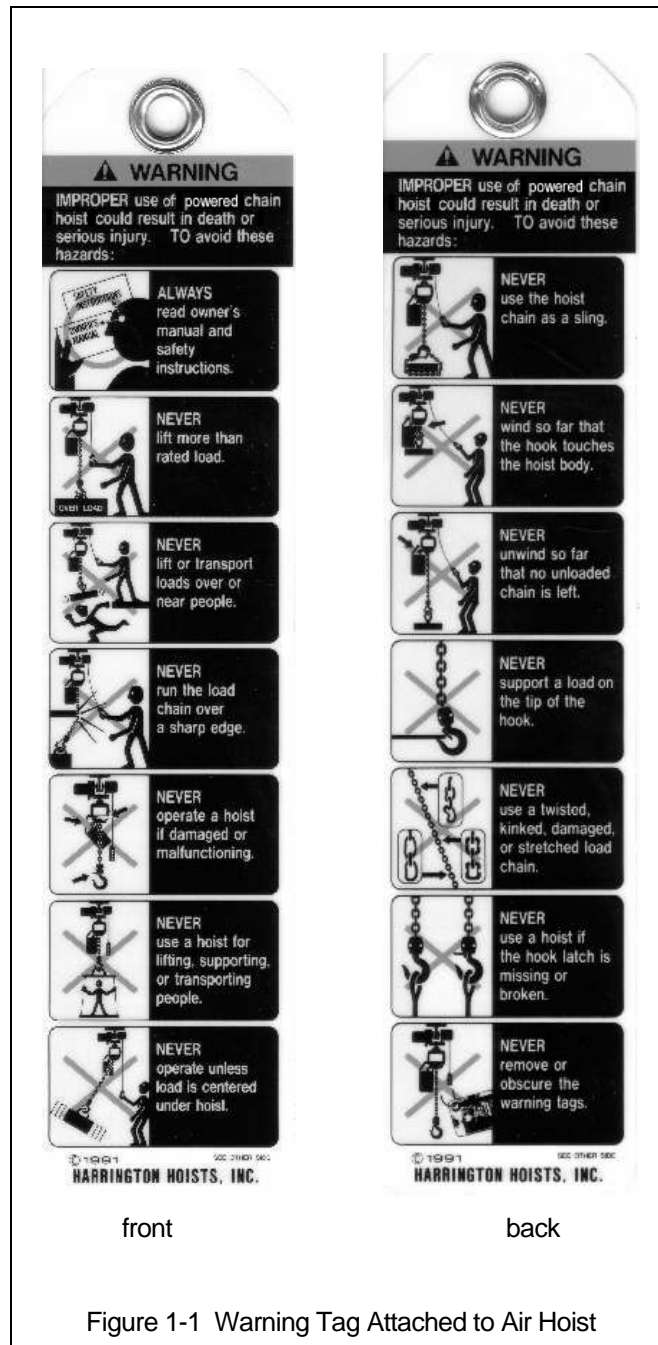
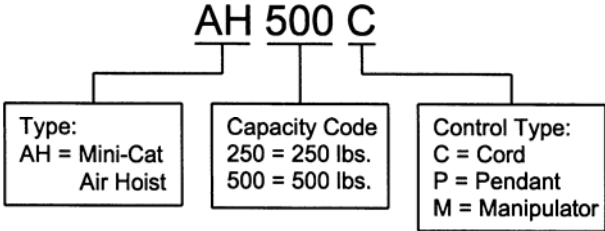

Figure 1-1 Warning Tag Attached to Air Hoist

## 2.0 Technical Information

### 2.1 Specifications

#### 2.1.1 Product Code



#### 2.1.2 Features and General Specifications:

- WEIGHT/SIZE – Light weight and compact size: cord model with 10 feet of lift weighs 15.2 lbs.
- MOTOR BRAKE – Reliable disc brake system
- HIGH SPEED LIFTING – 26 to 47 ft/min. with load
- LOW NOISE LEVELS – 76 dba @ 1 meter when lifting rated load  
82 dba @ 1 meter when lowering rated load
- VALVE SECTION – Valve made from aluminum reduces effects of corrosion
- COMPATIBILITY – Fits existing Harrington trolleys; uses existing EDII load chain
- OPERATING ENVIRONMENT – Temperature range +14° to 140°F
- DUTY RATING – High duty cycle

<b>Table 2-1 General Specifications</b>						
<b>Capacity (lbs.)</b>	<b>Product Code</b>	<b>Headroom (in)</b>	<b>Standard Lift (ft)</b>	<b>Load Chain Dia. (mm) x Chain Fall Lines</b>	<b>Net Weight with Standard Lift (lbs.)</b>	<b>Weight for Additional One Foot of Lift (lbs.)</b>
250	AH250C	12.0	10	4 x 1	15	0.26
500	AH500C	12.0	10	4 x 1	15	0.26
250	AH250P	12.0	10	4 x 1	19	0.49
500	AH500P	12.0	10	4 x 1	19	0.49
250	AH250M	33.0	6.5	4 x 1	24	0.47
500	AH500M	33.0	6.5	4 x 1	24	0.47

- MAXIMUM LIFT: 131 ft. for Pendant and Cord models; 13 ft. for Manipulator Model
- AIR LUBRICATION REQUIREMENTS: Minimum of 10 to 15 drops per minute (2-3 cc/min) of oil
- AIR FILTRATION REQUIREMENT: Maximum 5 micron air filter or finer.
- AIR SUPPLY PRESSURE: 60 to 90 psi.
- AIR CONSUMPTION: 19 to 34 cubic feet per minute.
- AIR INLET PORT SIZE: 3/8 inch NPT
- MINIMUM SUPPLY HOSE SIZE: 3/8 inch

## 2.2 Speeds, Air Consumptions and Dimensions

Table 2-2 Cord Model Speeds, ft/min at 90 psi*					
Capacity (lbs.)	Product Code	UP		DOWN	
		Full Load	No Load	Full Load	No Load
250	AH250C	47 (37)	61 (53)	51 (47)	45 (40)
500	AH500C	32 (20)	61 (53)	56 (54)	45 (40)

Table 2-3 Cord Model Air Consumption, CFM at 90 psi*					
Capacity (lbs.)	Product Code	UP		DOWN	
		Full Load	No Load	Full Load	No Load
250	AH250C	32 (24)	34 (27)	30 (24)	28 (23)
500	AH500C	29 (21)	34 (27)	32 (26)	28 (23)

\* Values in parentheses for air supply at 60 psi.

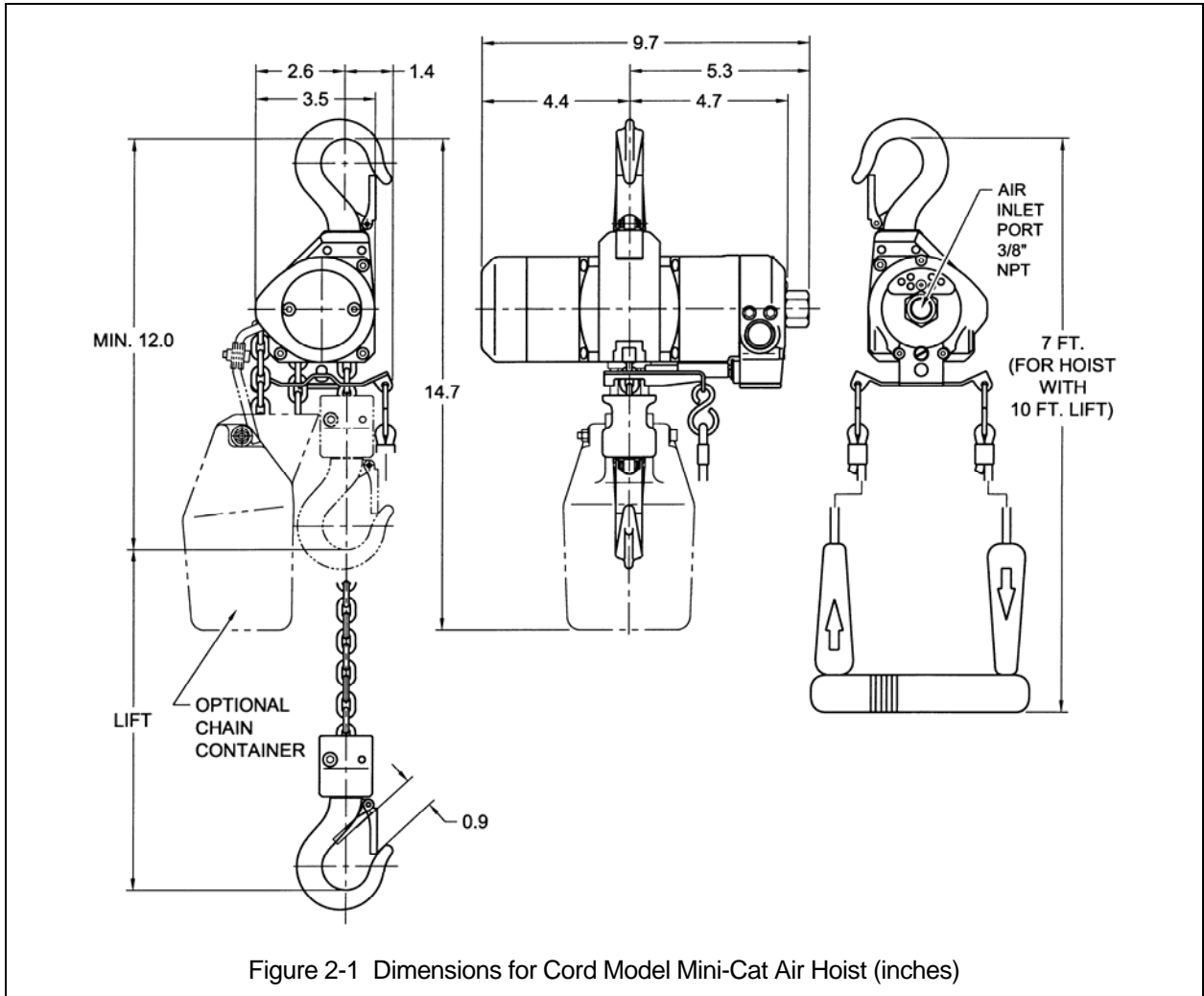

Table 2-4 Pendant Model Speeds, ft/min at 90 psi*					
Capacity (lbs.)	Product Code	UP		DOWN	
		Full Load	No Load	Full Load	No Load
250	AH250P	42 (33)	55 (48)	48 (45)	43 (38)
500	AH500P	29 (18)	55 (48)	53 (51)	43 (38)

Table 2-5 Pendant Model Air Consumption, CFM at 90 psi*					
Capacity (lbs.)	Product Code	UP		DOWN	
		Full Load	No Load	Full Load	No Load
250	AH250P	28 (21)	31 (24)	27 (21)	26 (20)
500	AH500P	26 (19)	31 (24)	28 (22)	26 (20)

\* Values in parentheses for air supply at 60 psi.

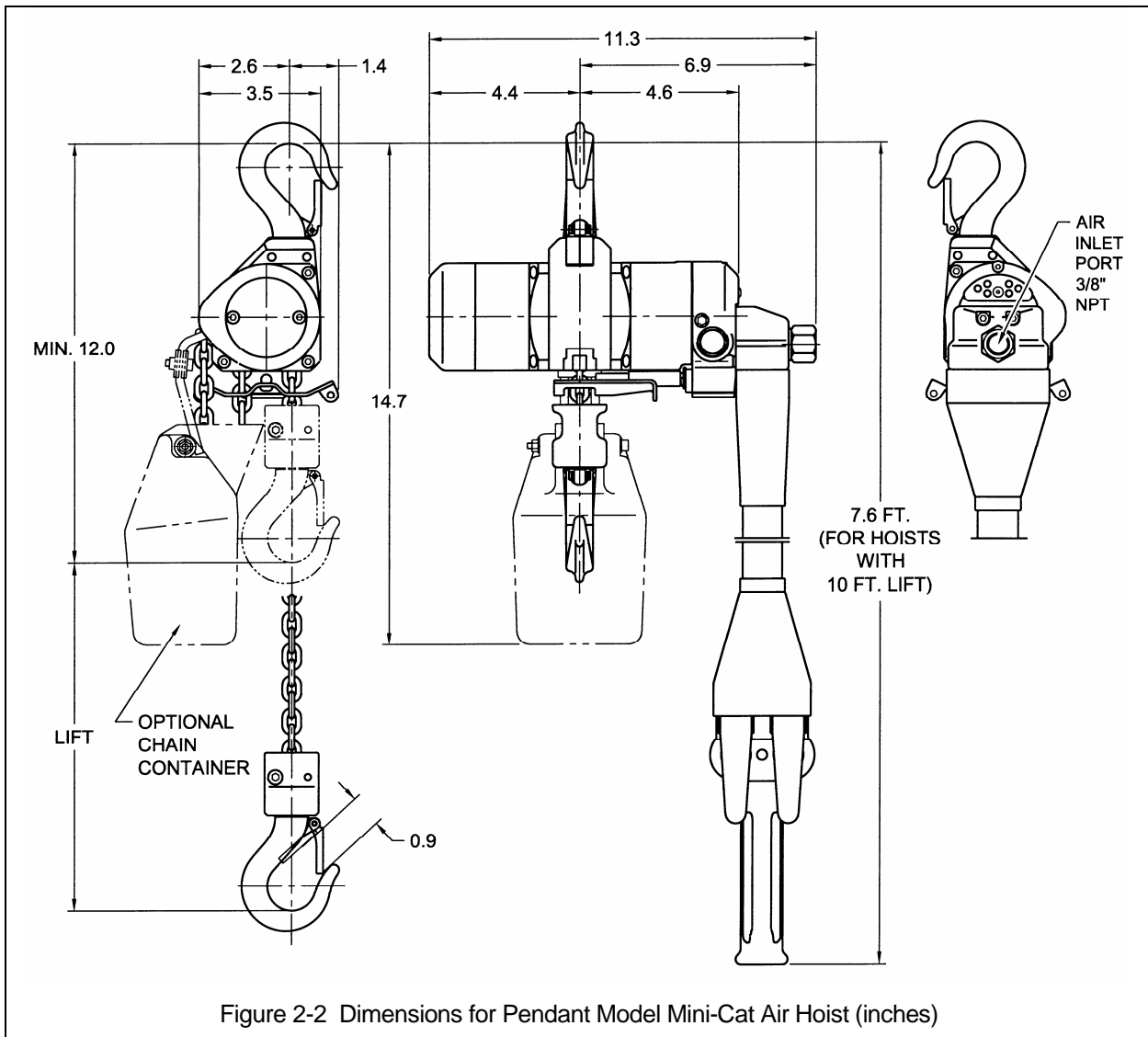
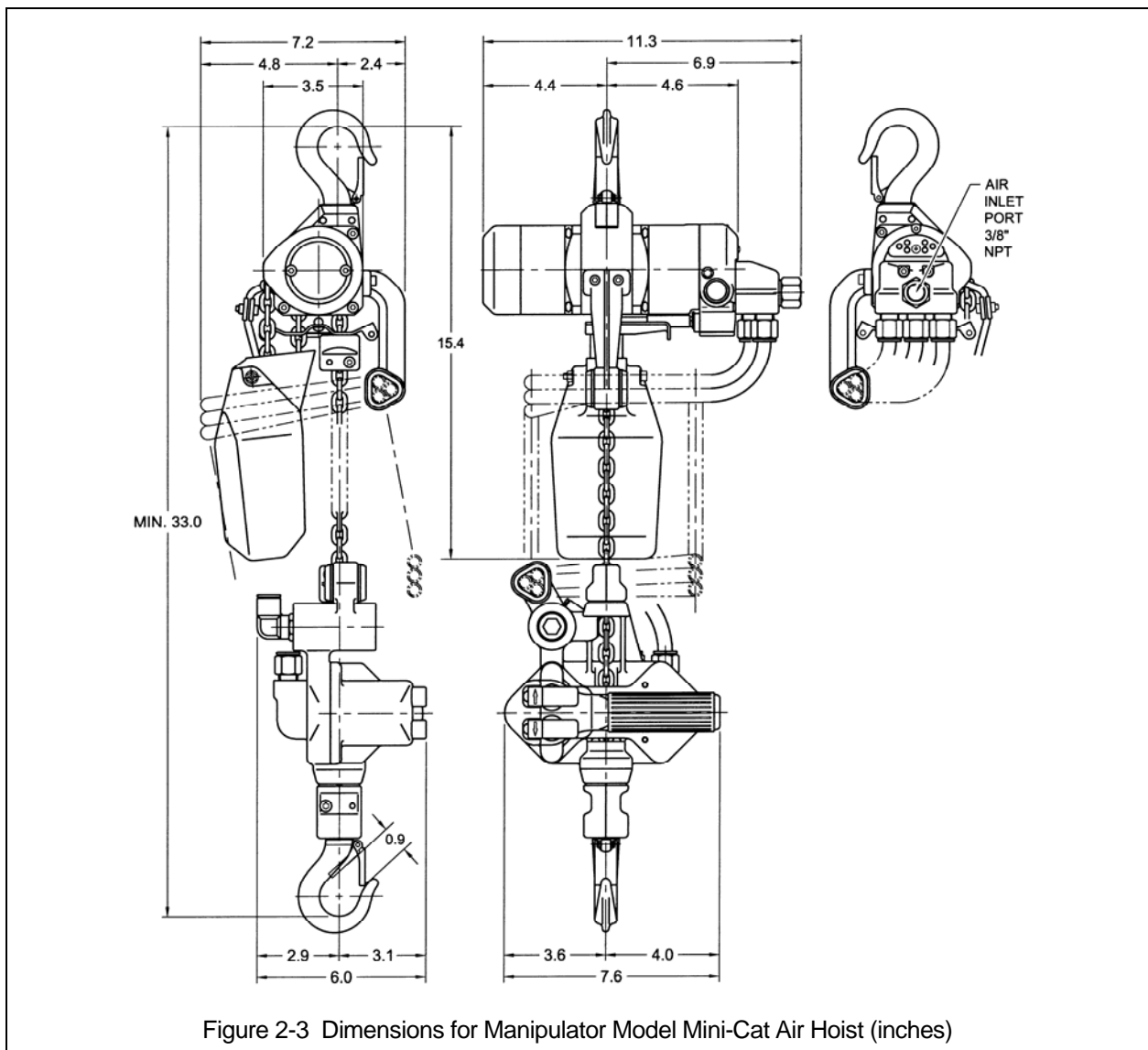

Table 2-6 Manipulator Model Speeds, ft/min at 90 psi*					
Capacity (lbs.)	Product Code	UP		DOWN	
		Full Load	No Load	Full Load	No Load
250	AH250M	41 (32)	54 (47)	47 (44)	42 (37)
500	AH500M	29 (18)	54 (47)	53 (50)	42 (37)

Table 2-7 Manipulator Model Air Consumption, CFM at 90 psi*					
Capacity (lbs.)	Product Code	UP		DOWN	
		Full Load	No Load	Full Load	No Load
250	AH250M	28 (21)	31 (24)	27 (21)	26 (20)
500	AH500M	26 (19)	31 (24)	28 (22)	26 (20)

\* Values in parentheses for air supply at 60 psi.



## 2.3 Part Names

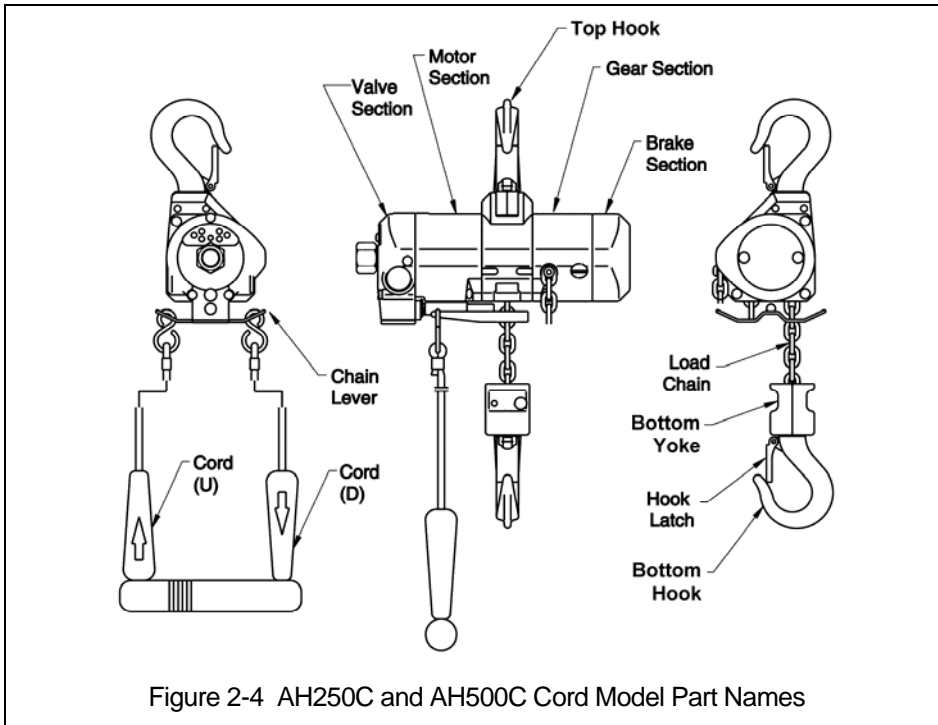

Figure 2-4 AH250C and AH500C Cord Model Part Names

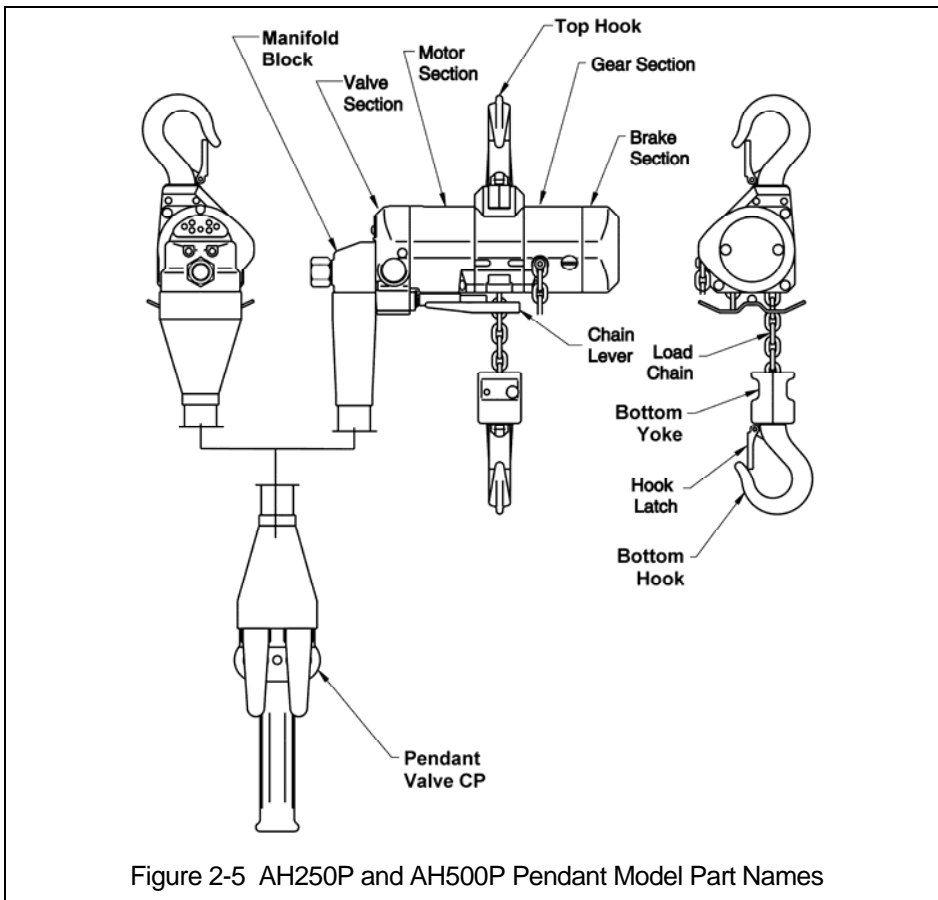

Figure 2-5 AH250P and AH500P Pendant Model Part Names

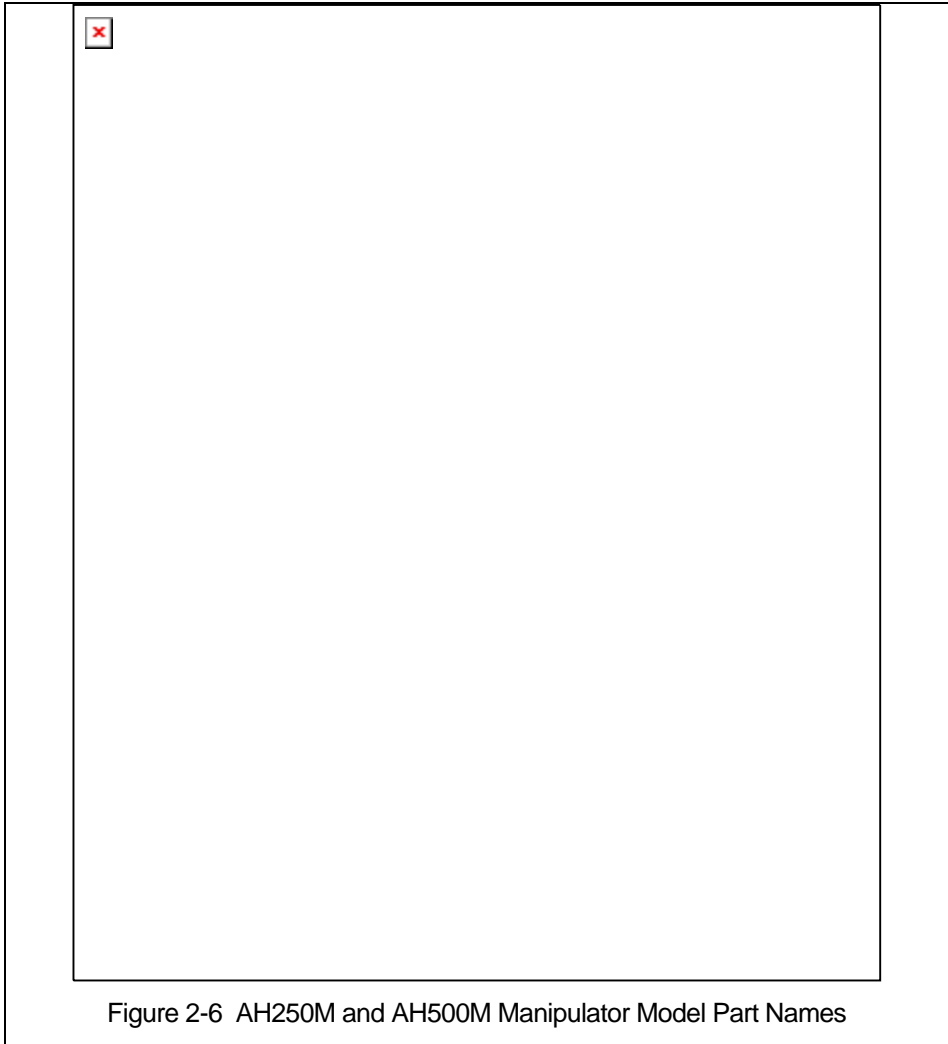

Figure 2-6 AH250M and AH500M Manipulator Model Part Names

## 3.0 Pre-operational Procedures

### 3.1 Air Supply System Requirements

- 3.1.1 **NOTICE** Pressure and Flow - Verify that the air supply system has capacity to supply your air hoist with required pressure and flow. Otherwise the hoist may operate poorly or may fail to operate. See [Section 3.2](#).
- 3.1.2 **CAUTION** Lubrication - The hoist requires lubrication for proper operation. The oil in the air supply is the primary source of lubrication to the hoist. Therefore, a dedicated air supply lubricator must be used with the hoist. Refer to [Section 3.3](#).
- 3.1.3 **CAUTION** Air Quality - Good air quality is essential to prevent damage to your hoist and to ensure its proper operation. The air must be clean and free of debris such as dirt and rust. Refer to [Section 3.4](#) for filtration requirements. The air must also be dry; free of moisture and water. Refer to [Section 3.5](#).

### 3.2 Air Supply Capacity and Regulation

- 3.2.1 Capacity - The air supply system must be capable of delivering the required airflow (cfm) to the hoist inlet port. Without the required airflow the hoist will not operate properly or may not operate at all. See [Section 2.0](#) for your hoist's air consumption requirements. In determining if your system is capable of supplying the required airflow, consider the following:
- Capacity of compressor(s) and tank
  - Other air consuming equipment
  - Flow restrictions such as pipes, hoses, valves and fittings
- Inadequate capacity will cause a significant drop in pressure when the hoist is operated, and could cause poor performance or failure to operate.
- 3.2.2 Regulation - The hoist requires a constant supply of air at a pressure of between 60 and 90 psi. If the air supply is not regulated or is regulated at a pressure greater than 90 psi, then a regulator must be used. The regulator may be located anywhere up-line of the lubricator in the air supply to the hoist.

### 3.3 Lubrication

- 3.3.1 **CAUTION** The hoist must be supplied with its own lubricator. The lubricator must be located as follows:
- 1) **Best location** - At the hoist inlet. In this case the lubricator can be either the mist type or drop type.
  - 2) **Second best location** - No more than 15 feet away from the hoist, at the same elevation or above the hoist inlet. In this case the mist type lubricator must be used.
  - 3) **Third best location** - No more than 15 feet away below the hoist. In this case the mist type lubricator must be used.
- 3.3.2 **CAUTION** The lubricator must be set to deliver the equivalent of 10 to 15 drops of oil per minute (2 to 3 cc/minute). The hoist's exhaust will emit a fine oil mist when properly lubricated. Refer to [Section 6.1](#) for type of oil to use.

### 3.4 Filtration

3.4.1 **⚠ CAUTION** The air entering the hoist inlet must not contain any particulate greater than 5 microns in size. Therefore, the hoist must have a 5 micron filter in its air supply. The filter must be upstream of the lubricator.

3.4.2 The filter servicing the hoist can also service other hoists and air consuming equipment. In this case, the air filter must be in sized for the total air consumption of the equipment it is servicing.

### 3.5 Air Dryer

3.5.1 **⚠ CAUTION** To prevent corrosion and hoist malfunction, employ an air dryer in the air supply system to ensure that dry air is supplied to the hoist. If there is moisture in the air supplied to the hoist, this moisture will cause corrosion on internal hoist components during periods when the hoist is idle leading to hoist malfunction.

### 3.6 Piping, Hoses And Fittings

3.6.1 **⚠ CAUTION** System Configuration - The system should be configured as shown in [Figure 3-1](#). Since moisture tends to accumulate in compressed air systems, corrosion may result if the system is not periodically drained.

- Arrange for a drain in the air supply piping at the lowest point in the piping, and
- Periodically drain the system to remove moisture/water from the system and to prevent corrosion.
- Filter, regulator (if equipped), and lubricator must be arranged in the order shown in [Figure 3-2](#).

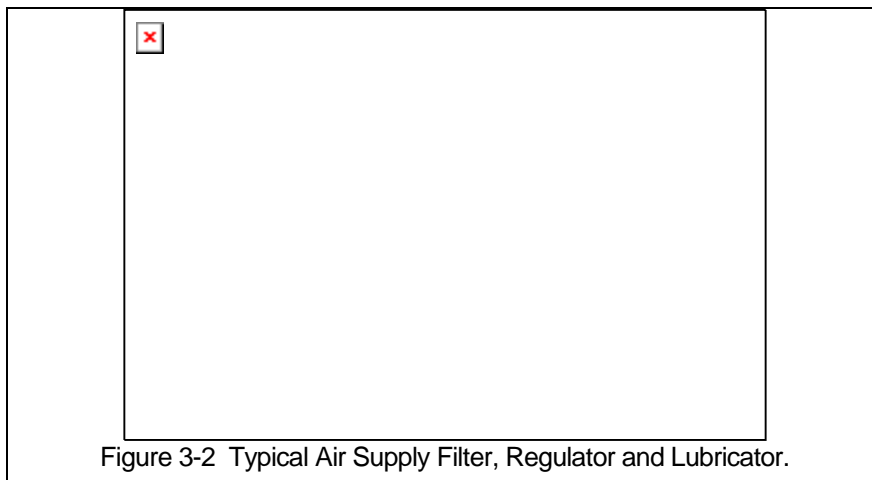
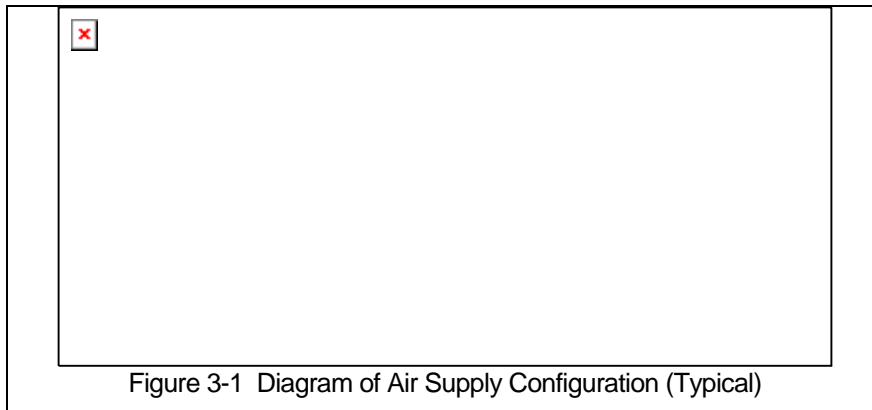

3.6.2 **NOTICE** Supply line inside diameter - Pipes and hoses should be sized to accommodate the hoist's airflow requirements. The inside diameter for the pipe section feeding the hoist should be 1/2 inch or larger and for air supply hose the inside diameter should be 3/8 inch or larger

3.6.3 **NOTICE** Hoses - The connection from the air supply system piping to the hoist must be made with a flexible pressure hose. Due to normal line losses in air supply lines:

- Do not use hose smaller than specified in [Section 3.6.2](#), and
- Limit the length of the hose to that specified in [Figure 3-3](#).

If your application exceeds these requirements consult factory.



Figure 3-3 Typical Arrangements of Filter, Regulator and Lubricator and Maximum Air Supply Hose Lengths

3.6.4 **CAUTION** Fittings - Important considerations regarding fittings in the hoist's air supply include:

- When connecting air supply components, remove all dirt or debris from the connecting surfaces of the hoses, pipes, fittings, or threaded fasteners to prevent contaminants from entering the hoist.
- Keep airflow restrictions such as quick disconnect fittings, bends, elbows, and adapters to a minimum.

3.6.5 **CAUTION** Before connecting the hoist to its air supply line, perform the proper draining and purging procedures to prevent contaminants or moisture from entering the hoist.

### 3.7 Mounting Location

3.7.1 **WARNING** Prior to mounting the hoist ensure that the suspension and its supporting structure are adequate to support the hoist and its loads. If necessary consult a professional that is qualified to evaluate the adequacy of the suspension location and its supporting structure.

3.7.2 **NOTICE** See [Section 7.6](#) for outdoor installation considerations.

### 3.8 Connecting Hoist to Air Supply

3.8.1 **⚠ WARNING** HAZARDOUS AIR PRESSURE IS PRESENT IN THE HOIST, IN THE SUPPLY OF COMPRESSED AIR TO THE HOIST, AND IN THE CONNECTIONS BETWEEN COMPONENTS.

3.8.2 Shut off the air supply and stop the airflow completely. Lock out and tag out in accordance with ANSI Z244.1 "Personnel Protection -Lockout/Tagout of Energy Sources".

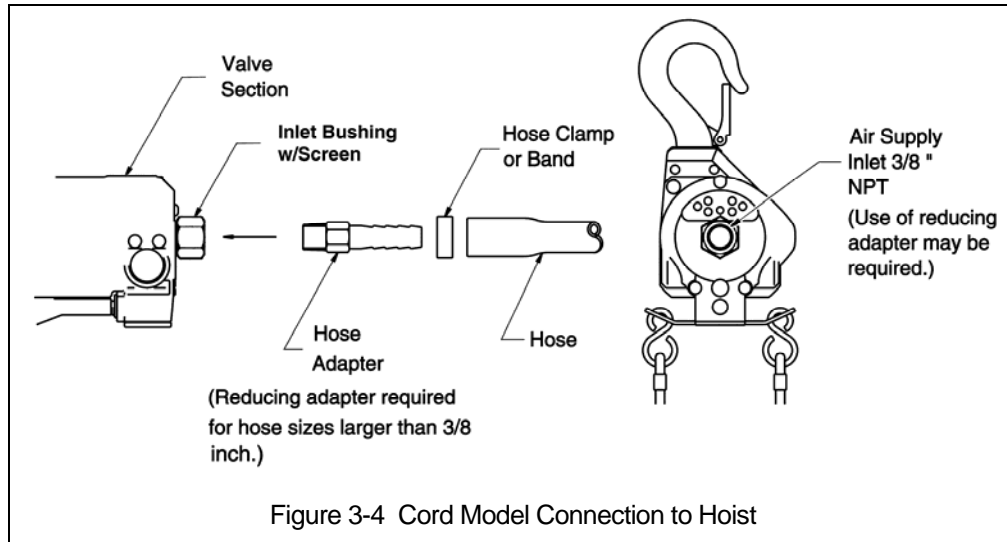

Figure 3-4 Cord Model Connection to Hoist

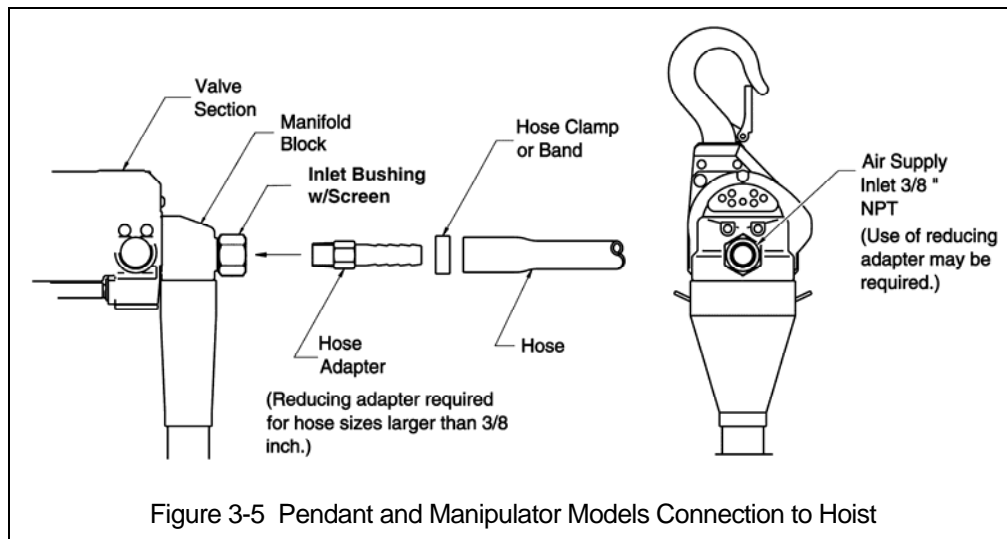

Figure 3-5 Pendant and Manipulator Models Connection to Hoist

3.8.3 **⚠ CAUTION** Before connecting the air supply hose to the hoist, always purge the air hose to clear any debris and water.

3.8.4 Apply approximately 10-15 drops of turbine oil (see approved lubricant under [Section 6.0](#) Lubricants) into the hose before attaching to the hoist.

3.8.5 Make connections to air supply; reference [Figure 3-4](#) or [3-5](#). Use a reducing adapter at the hoist valve section for hose sizes larger than 3/8 inch.

3.8.6 **NOTICE** Where conditions dictate, the installation sequence can be reversed by mounting the hoist first ([Section 3.9](#)) followed by connecting the air supply.

### 3.9 Mounting the Hoist

3.9.1 Mini Trolley - Follow instructions below to install the trolley. Refer to [Figure 3-6](#).

- 1) Remove the Top Hook Complete Set from the hoist and install the Suspender.
- 2) Refer to [Table 3-1](#) for placement of Adjusting Spacers for the flange width "B" of the traversing beam. The position of spacers differs with flange width. If the beam flange width is not listed in [Table 3-1](#), use the next size smaller and make adjustments in accordance with step 3. Use all 32 adjusting spacers provided.
- 3) Refer to [Figure 3-6](#) and assemble the trolley Frames, Adjusting Spacers and Socket Bolts onto the Suspender. Install and hand tighten the plain Nuts on the Socket Bolts. Verify that dimension "A" is approximately 0.12 - 0.16 in (3-4mm) greater than "B" (flange width). If "A" does not fall within the specified range, move spacers from inner to outer or from outer to inner as necessary to obtain the proper "A" dimension, irrespective of the numbers in [Table 3-1](#).
- 4) Install the trolley and hoist onto traversing beam using one of the following 2 methods:
  - Preferred Method – Sliding the trolley connected with hoist onto the traversing beam from the beam end is the most convenient and recommended method. If the trolley can be mounted from the end of the beam then: Remove the trolley end-stop from the beam and set the trolley on the beam from the end. Securely re-install the trolley end stop on the beam.
  - Optional Method – If the trolley cannot be mounted from the end of the beam, loosen the plain Nuts and spread the trolley Frames. Lift the trolley and hoist onto the beam from below. Push the trolley frames together and hand tighten the plain Nuts.
- 5) Check for contact between all four trolley wheels and the rail surface. Shift the Trolley Frame until all trolley wheels rest on the rail surface. Tighten the plain Nuts and install the two U-Nuts onto the Socket Bolts tighten against the plain Nuts. Install the Split Pins onto the Socket Bolts and bend securely.
- 6) **⚠ WARNING** Incorrect number of adjusting spacers may cause the trolley to not move or to drop. To avoid these hazards, always make sure to use all 32 spacers and confirm that  $A - B = 0.12 - 0.16$  in (3-4mm).
- 7) **⚠ WARNING** To prevent the trolley from dropping, firmly fasten the Socket Bolt, Nut and U-Nut. Insert split pin and bend the ends 90 degrees or more.

Rail Width (in)	Outside left frame	Inside left frame	Inside right frame	Outside right frame
2	8	8	6	8
2 5/16	6	9	8	7
2 1/2	6	10	8	6
2 11/16	5	10	9	6
2 13/16	5	11	9	5
3	4	12	10	4
3 1/4	3	13	11	3
3 5/16	3	13	11	3
3 9/16	2	14	12	2
3 11/16	1	14	13	2
3 7/8	0	15	14	1
3 15/16	0	16	14	0

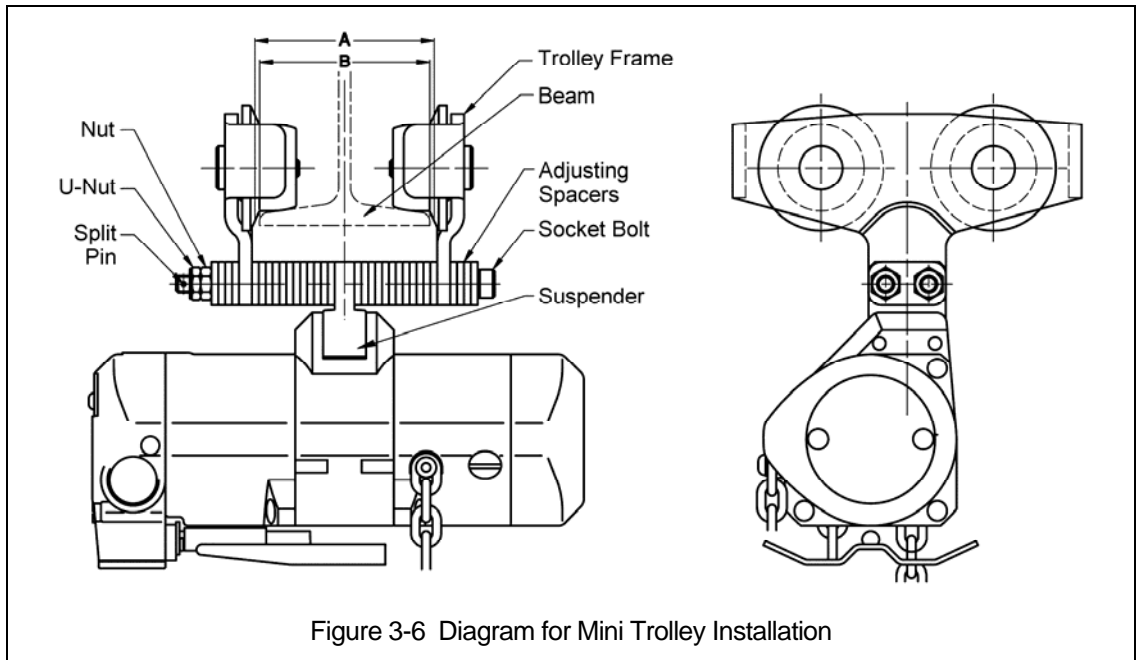

- 3.9.2 Manual Trolley - Follow instructions in Owner's Manual provided with the trolley.
- 3.9.3 Motorized Trolley - Follow instructions in Owner's Manual provided with the trolley.
- 3.9.4 Hook Mounted to a Fixed Location - Attach the hoist's top hook to the fixed suspension point.
- 3.9.5 **⚠ WARNING** Ensure that the fixed suspension point rests on the center of the hook's saddle and that the hook's latch is engaged.

### 3.10 Optional Chain Container

- 3.10.1 Follow instructions below to install the optional chain container. Refer to [Figure 3-7](#).
  - 1) Insert the Bucket Arm Assembly into the notched openings on the Wheel Housing.
  - 2) Loosely attach the Arm Holders to the Bucket Arm Assembly with the Bolt, Washers and U-Nut provided.
  - 3) Attach the Chain Container onto the Bucket Arm Assembly with the Socket Bolt BP, U-Nut and Split Pin. Make Sure to Securely bent the Split Pin.
  - 4) Tighten the Bolt and U-Nut on the Arm Holders.
  - 5) Feed the Chain into the Chain Container beginning with the no-load end. Take care to avoid twisting or tangling the Chain.
  - 6) **⚠ CAUTION** Do not use the Chain Container if any parts are damaged or if any fasteners/hardware are missing.

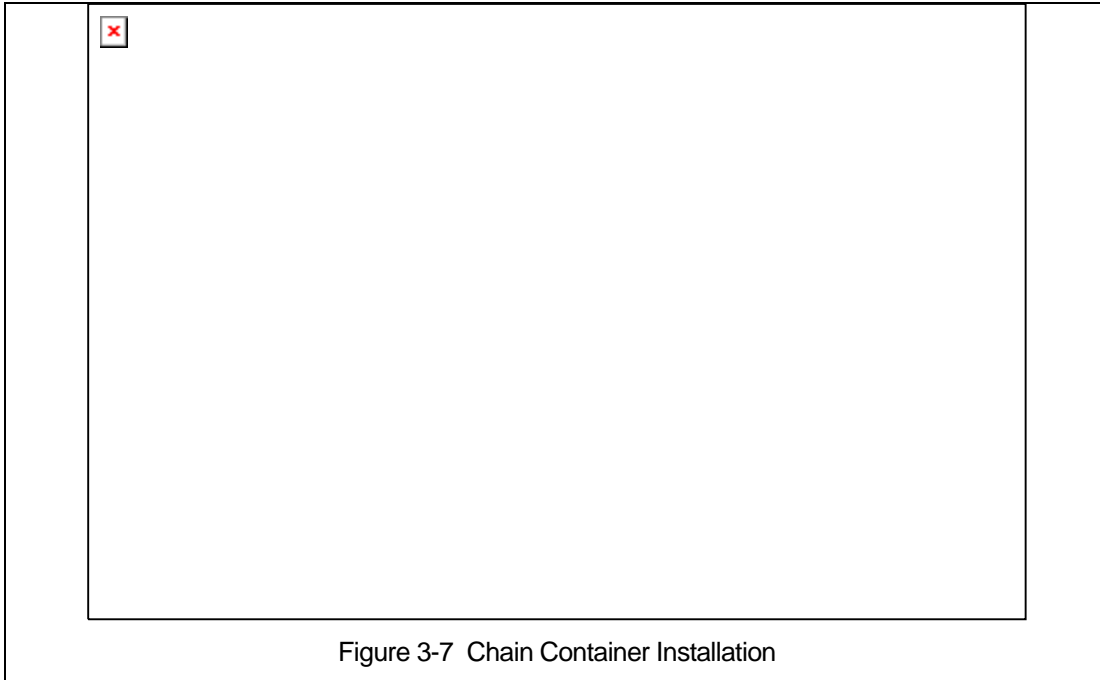

### 3.11 Non-Stationary Application

- 3.11.1 For applications such as rental fleets or construction sites where the hoist is moved from place-to-place, a filter and lubricator are still required. Consult factory for recommended methods.
- 3.11.2 Connections and fittings must be kept clean and care taken to prevent dirt, debris and moisture from entering the hoist.
- 3.11.3 Recommended practice for removing the hoist from an installation:
  - 1) Run the hoist briefly with well lubricated air
  - 2) Shut off the air supply to the hoist, bleed off any pressure in the system then disconnect the air supply line.
  - 3) Inject a small quantity (approximately 20 drops) of turbine oil (see [Section 6.0](#)) into the hoist's inlet port
  - 4) Plug the inlet port

### 3.12 Manipulator Right or Left Hand Operation

- 3.12.1 Follow instructions below to configure for right or left-hand operation. Refer to [Figure 3-8](#).
  - 1) **⚠ WARNING** HAZARDOUS AIR PRESSURE IS PRESENT IN THE HOIST, IN THE SUPPLY OF COMPRESSED AIR TO THE HOIST, AND IN THE CONNECTIONS BETWEEN COMPONENTS. Shut off the air supply and stop the airflow completely. Bleed off any pressure in the system. Lock out and tag out in accordance with ANSI Z244.1 "Personnel Protection - Lockout/Tagout of Energy Sources".
  - 2) Remove the 6 Button Head Screws located on the back side of the Manipulator control then remove the Throttle Valve Complete.
  - 3) Make sure the 8 O-Rings and 2 Spring Pins are correctly positioned, then rotate the Throttle Valve Complete 180 degrees and re-install.
  - 4) Re-install and tighten the 6 Button Head Screws
  - 5) Re-connect or turn on the air supply and check for leaks and proper operation.

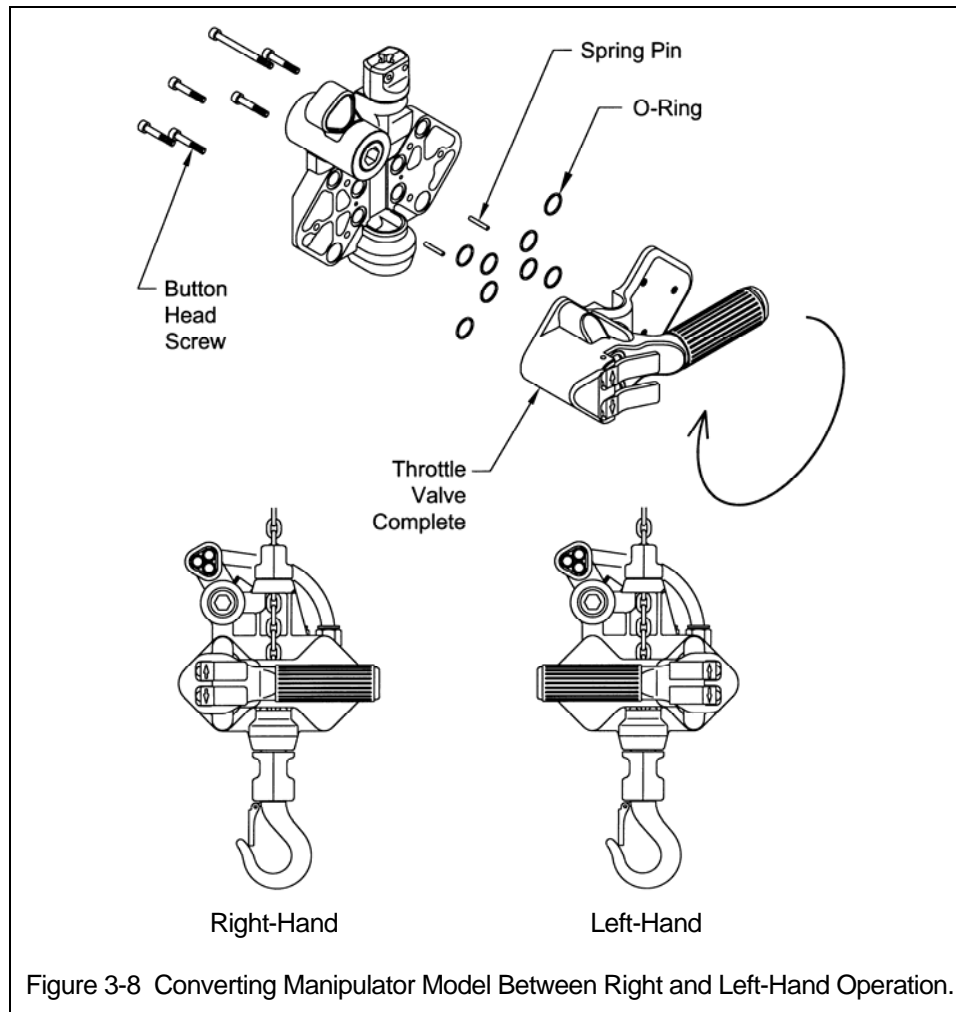

Figure 3-8 Converting Manipulator Model Between Right and Left-Hand Operation.

### 3.13 Manipulator Model's Bottom Hook Position

3.13.1 The Bottom Hook can be extended below the manipulator control to allow for easier load attachment and operation as required by the application. Follow instructions below. Refer to [Figure 3-9](#).

- 1) Run the hoist in the down direction until there is a sufficient amount of Load Chain below the hoist.
- 2) **⚠️ WARNING** HAZARDOUS AIR PRESSURE IS PRESENT IN THE HOIST, IN THE SUPPLY OF COMPRESSED AIR TO THE HOIST, AND IN THE CONNECTIONS BETWEEN COMPONENTS. Shut off the air supply and stop the airflow completely. Bleed off any pressure in the system. Lock out and tag out in accordance with ANSI Z244.1 "Personnel Protection - Lockout/Tagout of Energy Sources".
- 3) Remove both Hangers from the Load Chain.
- 4) Slide the Manipulator Control up the Load Chain to the desired position then reinstall the bottom Hanger onto the Load Chain.
- 5) Refer to the minimum dimensions between the hangers shown in Figure 3-9. Measure up from the bottom Hanger and reinstall the top Hanger onto the Load Chain.



- 3.14.6 If hoist is installed on a trolley, ensure that
- trolley is properly installed on the beam, and
  - stops for the trolley are correctly positioned and securely installed on the beam.
- 3.14.7 Ensure that all nuts, bolts and split (cotter) pins are sufficiently fastened.
- 3.14.8 For Pendant model hoists, ensure that the Pendant Hoses/Tubes are properly attached to the hoist and Pendant Valve CP. See [Section 7.3](#).
- 3.14.9 For Manipulator model hoists, ensure that the Coil Hose is properly attached to the hoist and Manipulator Control. See [Section 7.3](#).
- 3.14.10 **⚠ CAUTION** Check Air Supply - Check air supply before everyday use. Ensure proper air quality and air pressure.
- 3.14.11 **⚠ CAUTION** Check the lubricator for proper function and adequate oil level.
- 3.14.12 Confirm proper operation.
- Before operating read and become familiar with [Section 4 - Operation](#).
  - Before operating ensure that the hoist (and trolley) meets the Inspection, Testing and Maintenance requirements of ANSI/ASME B30.16.
  - Before operating ensure that nothing will interfere with the full range of the hoist's (and trolley's) operation.
- 3.14.13 Proceed with trial operation to confirm proper operation.
- **⚠ CAUTION** Make sure hook travel is in the same direction as shown on controls.
  - Initially operate slowly under no load in both directions.
  - Perform inspections per [Section 5.3](#), "Frequent Inspections".

## 4.0 Operation

### 4.1 Introduction

#### **DANGER**

DO **NOT** WALK UNDER A SUSPENDED LOAD

#### **WARNING**

HOIST OPERATORS SHALL BE REQUIRED TO READ THE OPERATION SECTION OF THIS MANUAL, THE WARNINGS CONTAINED IN THIS MANUAL, INSTRUCTION AND WARNING LABELS ON THE HOIST OR LIFTING SYSTEM, AND THE OPERATION SECTIONS OF ANSI/ASME B30.16 and ANSI/ASME B30.10. THE OPERATOR SHALL ALSO BE REQUIRED TO BE FAMILIAR WITH THE HOIST AND HOIST CONTROLS BEFORE BEING AUTHORIZED TO OPERATE THE HOIST OR LIFTING SYSTEM.

HOIST OPERATORS SHOULD BE TRAINED IN PROPER RIGGING PROCEDURES FOR THE ATTACHMENT OF LOADS TO THE HOIST HOOK.

HOIST OPERATORS SHOULD BE TRAINED TO BE AWARE OF POTENTIAL MALFUNCTIONS OF THE EQUIPMENT THAT REQUIRE ADJUSTMENT OR REPAIR, AND TO BE INSTRUCTED TO STOP OPERATION IF SUCH MALFUNCTIONS OCCUR, AND TO IMMEDIATELY ADVISE THEIR SUPERVISOR SO CORRECTIVE ACTION CAN BE TAKEN.

HOIST OPERATORS SHOULD HAVE NORMAL DEPTH PERCEPTION, FIELD OF VISION, REACTION TIME, MANUAL DEXTERITY, AND COORDINATION.

HOIST OPERATORS SHOULD **NOT** HAVE A HISTORY OF OR BE PRONE TO SEIZURES, LOSS OF PHYSICAL CONTROL, PHYSICAL DEFECTS, OR EMOTIONAL INSTABILITY THAT COULD RESULT IN ACTIONS OF THE OPERATOR BEING A HAZARD TO THE OPERATOR OR TO OTHERS.

HOIST OPERATORS SHOULD **NOT** OPERATE A HOIST OR LIFTING SYSTEM WHEN UNDER THE INFLUENCE OF ALCOHOL, DRUGS, OR MEDICATION.

OVERHEAD HOISTS ARE INTENDED ONLY FOR VERTICAL LIFTING SERVICE OF FREELY SUSPENDED UNGUIDED LOADS. DO **NOT** USE HOIST FOR LOADS THAT ARE NOT LIFTED VERTICALLY, LOADS THAT ARE NOT FREELY SUSPENDED, OR LOADS THAT ARE GUIDED.

#### **NOTICE**

- Read ANSI/ASME B30.16 and ANSI/ASME B30.10.
- Read the hoist manufacturer's Operating and Maintenance Instructions.
- Read all labels attached to equipment.

The operation of an overhead hoist involves more than activating the hoist's controls. Per the ANSI/ASME B30 standards, the use of an overhead hoist is subject to certain hazards that cannot be mitigated by engineered features, but only by the exercise of intelligence, care, common sense, and experience in anticipating the effects and results of activating the hoist's controls. Use this guidance in conjunction with other warnings, cautions, and notices in this manual to govern the operation and use of your overhead hoist.

## 4.2 Shall's and Shall Not's for Operation

### **WARNING**

Improper operation of a hoist can create a potentially hazardous situation which, if not avoided, could result in death or serious injury, and substantial property damage. To avoid such a potentially hazardous situation **THE OPERATOR SHALL:**

- **NOT** lift more than rated load for the hoist.
- **NOT** operate unless load is centered under hoist.
- **NOT** use damaged hoist or hoist that is not working properly.
- **NOT** use hoist with twisted, kinked, damaged, or worn chain.
- **NOT** use the hoist to lift, support, or transport people.
- **NOT** lift loads over people.
- **NOT** apply load unless load chain is properly seated in the load sheave.
- **NOT** use the hoist in such a way that could result in shock or impact loads being applied to the hoist.
- **NOT** attempt to lengthen the load chain or repair damaged load chain.
- **NOT** operate hoist when it is restricted from forming a straight line from hook to hook in the direction of loading.
- **NOT** use load chain as a sling or wrap load chain around load.
- **NOT** apply the load to the tip of the hook or to the hook latch.
- **NOT** apply load if binding prevents equal loading on all load supporting chains.
- **NOT** operate beyond the limits of the load chain travel.
- **NOT** operate hoist with missing/damaged chain components.
- **NOT** leave load supported by the hoist unattended unless specific precautions have been taken.
- **NOT** allow the chain, or hook to be used as an electrical or welding ground.
- **NOT** allow the chain, or hook to be touched by a live welding electrode.
- **NOT** remove or obscure the warnings on the hoist.
- Be familiar with operating controls, procedures, and warnings.
- Make sure the unit is securely attached to a suitable support before applying load.
- Make sure load slings or other approved single attachments are properly sized, rigged, and seated in the hook saddle.
- Take up slack carefully - make sure load is balanced and load-holding action is secure before continuing.
- Make sure all persons stay clear of the supported load.
- Protect the hoist's load chain from weld splatter or other damaging contaminants.
- Report Malfunctions or unusual performances (including unusual noises) of the hoist and remove the hoist from service until the malfunction or unusual performance is resolved.
- Make sure hoist limit switches function properly.
- Warn personnel before lifting or moving a load.
- Warn personnel of an approaching load.

## **⚠ CAUTION**

Improper operation of a hoist can create a potentially hazardous situation which, if not avoided, could result in minor or moderate injury, or property damage. To avoid such a potentially hazardous situation **THE OPERATOR SHALL:**

- Maintain a firm footing or be otherwise secured when operating the hoist.
- Check brake function by tensioning the hoist prior to each lift operation.
- Use hook latches. Latches are to retain slings, chains, etc. under slack conditions only.
- Make sure the hook latches are closed and not supporting any parts of the load.
- Make sure the load is free to move and will clear all obstructions.
- Avoid swinging the load or hook.
- Make sure hook travel is in the same direction as shown on controls.
- Inspect the hoist regularly, replace damaged or worn parts, and keep appropriate records of maintenance.
- Use the hoist manufacturer's recommended parts when repairing the unit.
- Lubricate load chain per hoist manufacturer's recommendations.
- **NOT** use limit switches as routine operating stops. They are emergency devices only.
- **NOT** allow your attention to be diverted from operating the hoist.
- **NOT** allow the hoist to be subjected to sharp contact with other hoists, structures, or objects through misuse.
- **NOT** adjust or repair the hoist unless qualified to perform such adjustments or repairs.

### 4.3 Hoist Controls

- 4.3.1 Cord Control - When using a hoist with cord control, pull down on the appropriate colored cord to raise or lower the load. White indicates the raise control and red indicates lowering control. Release the cords to stop the hoist. Refer to [Figure 4-1](#) below.
- 4.3.2 Pendant and Manipulator Controls – When using a hoist with pendant or manipulator control, depress the “up” lever to raise the load or the “down” lever to lower the load as shown in [Figure 4-1](#) below. To stop motion release the levers.

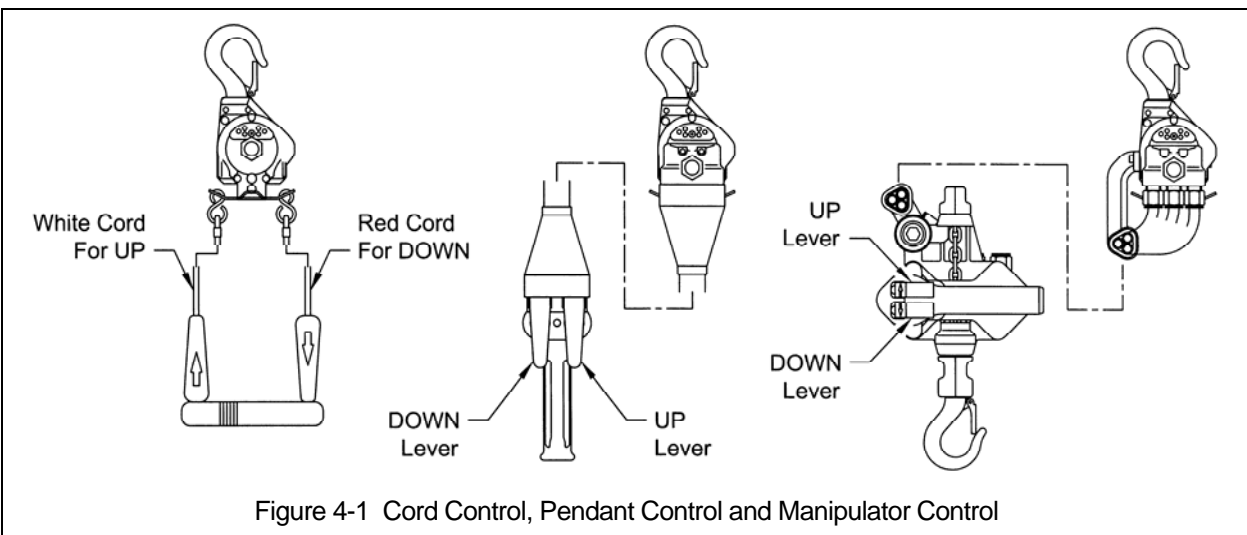

## 4.4 Controlling Hoist Speed

4.4.1 For the cord control, adjust the speed by varying the amount of pull on the cord. Refer to Figure 4-2.

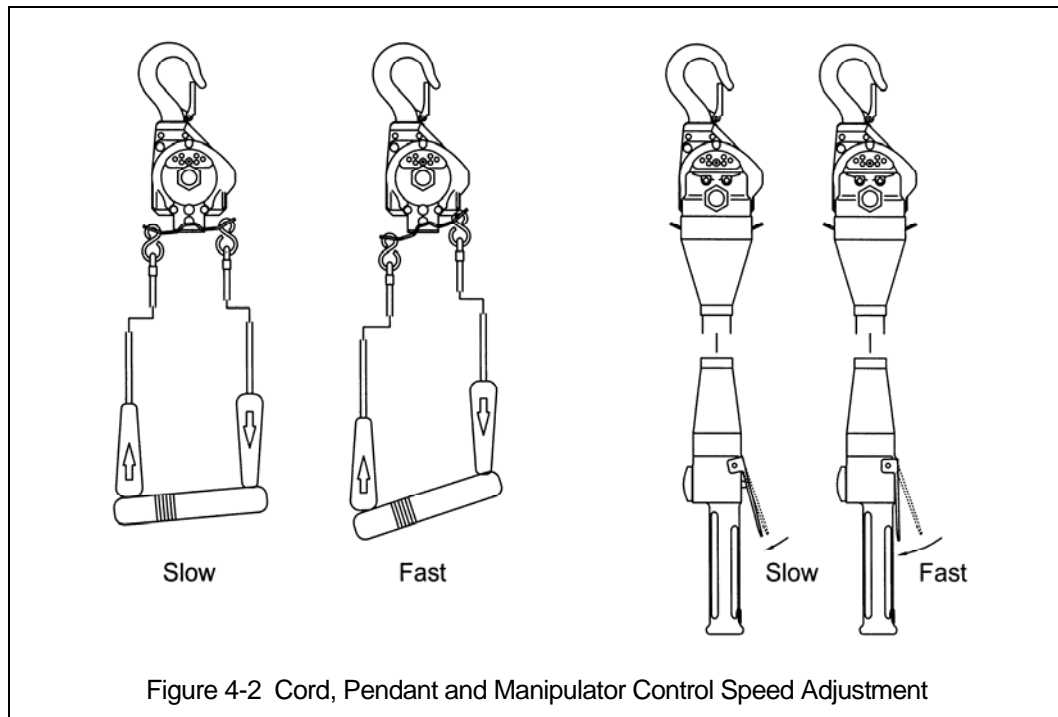

4.4.2 For the pendant or manipulator control, adjust the speed by varying the amount the lever is depressed. As shown in Figure 4-2, by depressing the lever slightly, you will be able to control the hoist's motions slowly and with more precision. By the depressing the lever further, the speed of the hoist will be increased until the lever is fully depressed.

## 5.0 Inspection

### 5.1 General

- 5.1.1 The inspection procedure herein is based on ANSI/ASME B30.16. The following definitions are from ANSI/ASME B30.16 and pertain to the inspection procedure below.
- **Designated Person** - a person selected or assigned as being competent to perform the specific duties to which he/she is assigned.
  - **Qualified Person** - a person who, by possession of a recognized degree or certificate of professional standing, or who, by extensive knowledge, training, and experience, has successfully demonstrated the ability to solve or resolve problems relating to the subject matter and work.
  - **Normal Service** - that distributed service which involves operation with randomly distributed loads within the rated load limit, or uniform loads less than 65% of rated load for not more than 25% of the time.
  - **Heavy Service** - that service which involves operation within the rated load limit which exceeds normal service.
  - **Severe Service** - that service which involves normal or heavy service with abnormal operating conditions.

### 5.2 Inspection Classification

- 5.2.1 Initial Inspection - prior to initial use, all new, altered, or modified hoists shall be inspected by a designated person to ensure compliance with the applicable provisions of this manual.
- 5.2.2 Inspection Classification - the inspection procedure for hoists in regular service is divided into two general classifications based upon the intervals at which inspection should be performed. The intervals in turn are dependent upon the nature of the critical components of the hoist and the degree of their exposure to wear, deterioration, or malfunction. The two general classifications are herein designated as FREQUENT and PERIODIC, with respective intervals between inspections as defined below.
- 5.2.3 FREQUENT Inspection - visual examinations by the operator or other designated personnel with intervals per the following criteria:
- Normal service - monthly
  - Heavy service - weekly to monthly
  - Severe service - daily to weekly
  - Special or infrequent service - as recommended by a qualified person before and after each occurrence.
- 5.2.4 PERIODIC Inspection - visual inspection by a designated person with intervals per the following criteria:
- Normal service - yearly
  - Heavy service - semiannually
  - Severe service - quarterly
  - Special or infrequent service - as recommended by a qualified person before the first such occurrence and as directed by the qualified person for any subsequent occurrences.

### 5.3 Frequent Inspection

- 5.3.1 Inspections should be made on a FREQUENT basis in accordance with [Table 5-1](#), “Frequent Inspection.” Included in these FREQUENT Inspections are observations made during operation for any defects or damage that might appear between Periodic Inspections. Evaluation and resolution of the results of FREQUENT Inspections shall be made by a designated person such that the hoist is maintained in safe working condition.

<b>Table 5-1 Frequent Inspection</b>
All functional operating mechanisms for maladjustment and unusual sounds.
Operation of limit switch and associated components
Hoist braking system for proper operation
Hooks in accordance with ANSI/ASME B30.10
Hook latch operation
Load chain in accordance with <a href="#">Section 5.7</a>
Air valves and components for leakage or damage

### 5.4 Periodic Inspection

- 5.4.1 Inspections should be made on a PERIODIC basis in accordance with [Table 5-2](#), “Periodic Inspection.” Evaluation and resolution of the results of PERIODIC Inspections shall be made by a designated person such that the hoist is maintained in safe working condition.
- 5.4.2 For inspections where load suspension parts of the hoist are disassembled, a load test per ANSI/ASME B30.16 must be performed on the hoist after it is re-assembled and prior to its return to service.

<b>Table 5-2 Periodic Inspection</b>
Requirements of frequent inspection.
Evidence of loose bolts, nuts, or rivets.
Evidence of worn, corroded, cracked, or distorted parts such as load blocks, suspension housing, chain attachments, clevises, yokes, suspension bolts, shafts, gears, bearings and pins.
Evidence of damage to hook retaining nuts or collars and pins, and welds or rivets used to secure the retaining members.
Evidence of damage or excessive wear of load sheaves.
Evidence of excessive wear on motor vanes or on load brake.
Evidence of damage of supporting structure or trolley, if used.
Function labels on pendant control stations for legibility.
Warning label properly attached to the hoist and legible (see <a href="#">Section 1.2</a> ).
End connections of load chain.

## 5.5 Occasionally Used Hoists

5.5.1 Hoists that are used infrequently shall be inspected as follows prior to placing in service:

- Hoist Idle More Than 1 Month, Less Than 1 Year: Inspect per FREQUENT Inspection criteria of [Section 5.3](#) above.
- Hoist Idle More Than 1 Year: Inspect per PERIODIC Inspection criteria of [Section 5.4](#) above.

## 5.6 Inspection Records

5.6.1 Dated inspection reports and records should be maintained at time intervals corresponding to those that apply for the hoist's PERIODIC interval per [Section 5.4](#) above. These records should be stored where they are available to personnel involved with the inspection, maintenance, or operation of the hoist.

5.6.2 A long range chain inspection program should be established and should include records of examination of chains removed from service so a relationship can be established between visual observation and actual condition of the chain.

## 5.7 Inspection Methods and Criteria

5.7.1 This section covers the inspection of specific items. The list of items in this section is based on those listed in ANSI/ASME B30.16 for the Frequent and Periodic Inspection. In accordance with ANSI/ASME B30.16, these inspections are not intended to involve disassembly of the hoist. Rather, disassembly for further inspection would be required if frequent or periodic inspection results so indicate. Such disassembly and further inspection should only be performed by a qualified person trained in the disassembly and re-assembly of the hoist.

**Table 5-3 Hoist Inspection Methods and Criteria**

Item	Method	Criteria	Action
Functional operating mechanisms.	Visual, Auditory	Mechanisms should be properly adjusted and should not produce unusual sounds when operated.	Repair or replace as required.
Limit Switch	Function	Proper operation. Actuation of limit switch should stop hoist.	Repair or replace as required.
Chain Lever Assembly	Visual, Function	Lever should not be bent or significantly worn and should be able to move freely.	Replace.
Braking System	Function	Braking distance should not exceed approximately five chain links.	Repair or replace as required.
Hooks - Surface Condition	Visual	Should be free of significant rust, weld splatter, deep nicks, or gouges.	Replace.
Hooks - Fretting wear	Measure	The "U" dimension should not be less than minimum value for discard from <a href="#">Table 5-6</a> (See <a href="#">Section 3.14</a> )	Replace.
Hooks - Stretch	Measure	The "K" dimension should not exceed the maximum value for discard from <a href="#">Table 5-6</a> (See <a href="#">Section 3.14</a> )	Replace.

<b>Table 5-3 Hoist Inspection Methods and Criteria</b>			
<b>Item</b>	<b>Method</b>	<b>Criteria</b>	<b>Action</b>
Hooks - Bent Shank or Neck	Visual	Shank and neck portions of hook should be free of deformations	Replace.
Hooks - Yoke Assembly	Visual	Should be free of significant rust, weld splatter, nicks, gouges. Holes should not be elongated, fasteners should not be loose, and there should be no gap between mating parts.	Clean/Lubricate, or replace as required.
Hooks - Swivel Bearing	Visual, Function	Bearing parts and surfaces should not show significant wear, and should be free of dirt, grime and deformations. Hook should rotate freely with no roughness.	Clean/lubricate, or replace as required.
Hooks - Hook Latches	Visual, Function	Latch should not be deformed. Attachment of latch to hook should not be loose. Latch spring should not be missing and should not be weak. Latch movement should not be stiff - when depressed and released latch should snap smartly to its closed position.	Replace.
Load Chain - Surface Condition	Visual	Should be free of rust, nicks, gouges, dents and weld splatter. Links should not be deformed, and should not show signs of abrasion. Surfaces where links bear on one another should be free of significant wear.	Replace.
Load Chain - Pitch and Wire Diameter	Measure	The "P" dimension should not be greater than maximum value listed in <a href="#">Table 5-7</a> . The "d" dimension should not be less than minimum value listed in <a href="#">Table 5-7</a> .	Replace, inspect Load Sheave.
Load Chain - Lubrication	Visual, Auditory	Entire surface of each chain link should be coated with lubricant and should be free of dirt and grime. Chain should not emit cracking noise when hoisting a load.	Clean/lubricate (see <a href="#">Section 6.0</a> ).
Load Chain - Reeving	Visual	Chain should be reeved properly through Load Sheave and properly attached to the hoist body - refer to <a href="#">Section 7.2</a> .	Install chain properly.
Chain Container (optional)	Visual	Container should not be damaged. Brackets should not be deformed or missing.	Replace
Bolts, Nuts and Rivets	Visual, Check with Proper Tool	Bolts, nuts and rivets should not be loose.	Tighten or replace as required.
Housing and Mechanical Components	Visual, Auditory, Vibration, Function	Hoist components including load blocks, suspension housing, chain attachments, clevises, yokes, suspension bolts, shafts, gears, bearings, pins and rollers should be free of cracks, distortion, significant wear and corrosion. Evidence of same can be detected visually or via detection of unusual sounds or vibration during operation.	Replace.

**Table 5-3 Hoist Inspection Methods and Criteria**

<b>Item</b>	<b>Method</b>	<b>Criteria</b>	<b>Action</b>
Chain Separator	Visual, Measure	The Chain Separator should be free of cracks, distortion, significant wear and corrosion. The "L" and "W" dimension should not be greater than maximum value listed in <b>Table 5-5</b> .	Replace
Motor Brake	Measure, Visual	Motor brake dimension should be within the allowable limits of <b>Table 5-4</b> . See <b>Section 7.1</b> for gaining access to motor brake. Braking surfaces should be clean, free of grease/oil and should not be glazed.	Replace
Load Sheave	Visual	Pockets of Load Sheave should be free of significant wear. See <b>Section 7.4</b> to gain visual access to the load sheave.	Replace.
Pendant Control Switches	Visual, Function	Depressing and releasing pendant control buttons should cause hoist to operate.	Repair or replace as necessary.
Pendant - Housing	Visual	Pendant housing should be free of cracks and mating surfaces of parts should seal without gaps.	Replace.
Pendant - Tubing	Visual, auditory	Tubing to pendant control switches should not be loose or be leaking air.	Repair or replace as necessary.
Warning Labels	Visual	Warning Labels should be affixed to the hoist (see <b>Section 1.2</b> ) and they should be legible.	Replace
Hoist Capacity Label	Visual	The label that indicates the capacity of the hoist should be legible and securely attached to the hoist.	Replace.

**Table 5-4 Brake Disc Dimension**

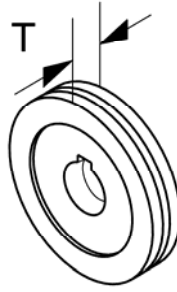

Hoists	Parts List Fig. No.	"T" Dimension inch (mm)	
		Standard	Discard
AH250C AH250P AH250M AH500C AH500P AH500M	72	0.31 (8)	0.29 (7.3)

**Table 5-5 Chain Separator Dimensions**

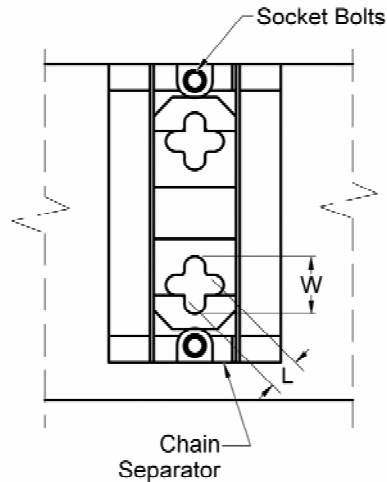

Hoists	Parts List Fig. No.	"L" Dimension inch (mm)		"W" Dimension inch (mm)	
		Standard	Discard	Standard	Discard
AH250C AH250P AH250M AH500C AH500P AH500M	92	0.33 (8.5)	0.41 (10.5)	0.61 (15.5)	0.69 (17.5)

**Table 5-6 Top Hook & Bottom Hook Dimensions**

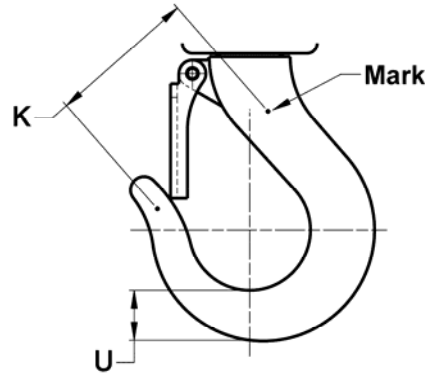

Dimensions K and U should be measured and recorded below prior to any use when the hook is first placed into service.

Hoists	Parts List Fig. No.	"K" Dimension inch (mm)		"U" Dimension inch (mm)	
		Recorded Dimension When New	Maximum /Minimum Value for Discard	Recorded Dimension When New	Maximum /Minimum Value for Discard
AH250C AH250P AH250M AH500C AH500P AH500M	140a	Top Hook K = _____	For K if the measured dimension exceeds <b>K(new) + 0.5mm</b> , the hook should be replaced.	Top Hook U = _____	For U if the measured dimension is less than <b>U(new) - 1mm</b> , the hook should be replaced.
	142a	Bottom Hook K = _____		Bottom Hook U = _____	

**Table 5-7 Chain Dimensions**

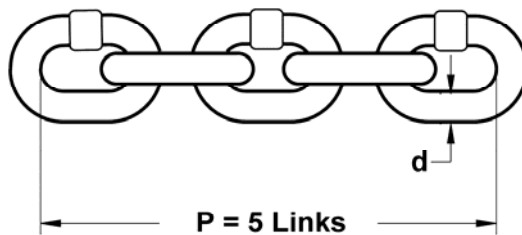

Hoists	"P" Dimension inch (mm)		"d" Dimension Wear Limit Inch (mm)	
	Standard	Discard	Standard	Discard
AH250C AH250P AH250M AH500C AH500P AH500M	2.38 (60.5)	2.43 (61.7)	0.16 (4.0)	0.13 (3.3)

## 6.0 Lubrication

### 6.1 Air Hoist Lubrication

6.1.1 See Section 3.0 for lubrication requirements.

6.1.2 **⚠ CAUTION** Lubrication to the motor will be provided primarily by the air supply lubricator. The recommended amount is 10-15 drops/minute (2-3cc/min.). Refer to [Table 6-1](#) below for the approved lubricant for use with your air hoist.

6.1.3 Additional lubrication to the reduction gears is not necessary. When disassembling the hoist for service or repair, apply new grease to the gears before reassembling the hoist.

### 6.2 Load Chain Lubrication

6.2.1 For longer life, lightly coat the load chain with machine or gear oil. Ensure that the oil is applied to the bearing surfaces of the load chain links.

6.2.2 The load chain lubrication should be accomplished after cleaning the load chain with acid free cleaning solution. Use approved lubricant in [Table 6-1](#) or equivalent.

6.2.3 For dusty environments, it is acceptable to substitute a dry lubricant.

### 6.3 Hooks and Suspension Components

6.3.1 Hooks - Bearings should be cleaned and lubricated at least once per year for normal usage. Clean and lubricate more frequently for heavier usage or severe conditions.

<b>Lubrication</b>	<b>Grade</b>	<b>Application</b>	<b>Part Location</b>
Turbine Oil	ISO VG 32-56 or equivalent	Air motor	Lubricator
Machine or gear oil	ISO VG 46-68 or equivalent	Load chain & pocket wheel	Load chain
Grease	National Lubricating Grease #3	Hook bearings	Top & bottom hook sets
Gears/Bearings	National Lubricating Grease #3	Gears & Bearings	Gear & Motor Section

## 7.0 Maintenance and Handling

### 7.1 Brake

7.1.1 The hoist brake is not adjustable.

7.1.2 Inspect the brake disc in accordance with [Section 5.7](#), [Table 5-3](#).

7.1.3 The following is the hoist brake inspection procedure. Refer to [Figure 7-1](#).

- 1) **⚠ WARNING** HAZARDOUS AIR PRESSURE IS PRESENT IN THE HOIST, IN THE SUPPLY OF COMPRESSED AIR TO THE HOIST, AND IN THE CONNECTIONS BETWEEN COMPONENTS. Shut off the air supply and stop the airflow completely. Lock out and tag out in accordance with ANSI Z244.1 "Personnel Protection -Lockout/Tagout of Energy Sources".
- 2) Gradually and evenly back out 2 Hex Socket Cap Screws (A) from Brake Cover (B) from Gear Case (J) to slowly decrease spring tension (K) of Brake Piston (D) against Brake Disc (I).
- 3) Remove Brake Cover (B), Brake Piston (D), Springs (K), and O-Rings from Gear Case (J). Set parts aside for reassembly.
- 4) Remove Retaining Ring (F) on Pinion Shaft (H) adjacent to Brake Disc (I).
- 5) Remove Brake Disc for inspection and measurement and then remove the Key (G) from the Pinion Shaft (H). Refer to "Motor Brake" in [Table 5-3](#), "Hoist Inspection Methods and Criteria".
- 6) Prior to reassembly, clean all surfaces of debris, dirt and loose paint. Apply a light film of grease to all O-Ring seals.
- 7) Reassemble in reverse order. Torque all mounting hardware evenly during the reassembly process.

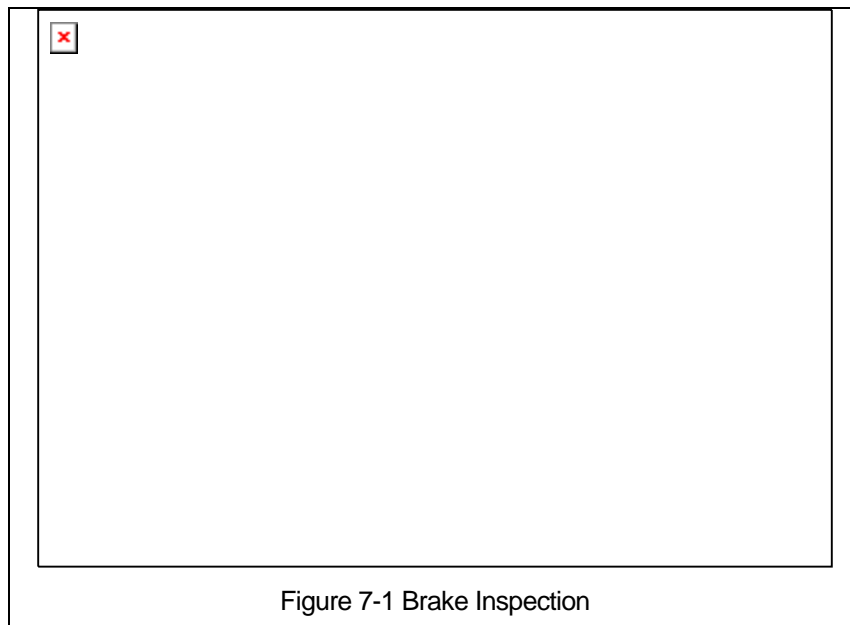

## 7.2 Load Chain

### 7.2.1 Lubrication and Cleaning

- Clean the chain with an acid-free cleaning solution. The load chain should be kept clean and lubricated.
- Lubrication - Clean and lubricate the load chain per [Section 6.0](#) at least once every 3 months for normal usage. Clean and lubricate more frequently for heavier usage or severe conditions.

### 7.2.2 Replacement

- 1) **⚠ CAUTION** An air supply line must be connected to the hoist in order to perform the following procedures.
- 2) **⚠ WARNING** Be certain that the replacement chain is obtained from Harrington and is the exact size, grade and construction as the original chain. The new load chain must have an even number of links so that the end links are oriented 90° from each other.
- 3) Remove the Bottom Hook Complete Set and Button Head Screw connecting the no-load end of the chain to the hoist body. Keep the Bottom Hook Complete Set and Button Head Screw for reuse on new chain. Carefully operate the hoist in the down direction to remove old chain.
- 4) **⚠ CAUTION** When replacing load chain, check for wear on mating parts, i.e. Load Sheave, Chain Guides, Bottom Hook Complete Set and replace parts if necessary. If the load chain is being replaced due to damage or wear out, destroy the old chain to prevent its reuse.
- 5) **⚠ CAUTION** Invert the hoist such that the chain separator openings are facing up and tilt the hoist approximately 30° as shown in [Figure 7-2](#). Insert the chain into the chain separator on the no-load side opening making certain that the first link is a standing link and that its weld is facing away from the centerline of the hoist.
- 6) **⚠ CAUTION** Operate the hoist as slowly as possible in the down direction to catch the Load Chain and pull it through the hoist. Make sure the chain feeds smoothly while operating the hoist. If binding occurs, stop and reverse the hoist direction to back the chain out. Reinsert the chain again while gradually operating hoist controls. Continue until a sufficient quantity of Chain is fed through the hoist to attach the Bottom Hook Complete Set.
- 7) Ensure that of the Chain remains free of twists and attach the no-load end of the chain to the hoist body with the Flat Washer and Button Head Screw. Reinstall the Bottom Hook Complete Set. Torque the Button Head Screw to 26 in-lbs. and the Bottom Hook's Socket Bolts to 95 in-lbs. Refer to [Figure 7-3](#).
- 8) After installation has been completed, perform steps outlined in [Section 3.14](#) "Pre-operational Checks and Trial Operation".

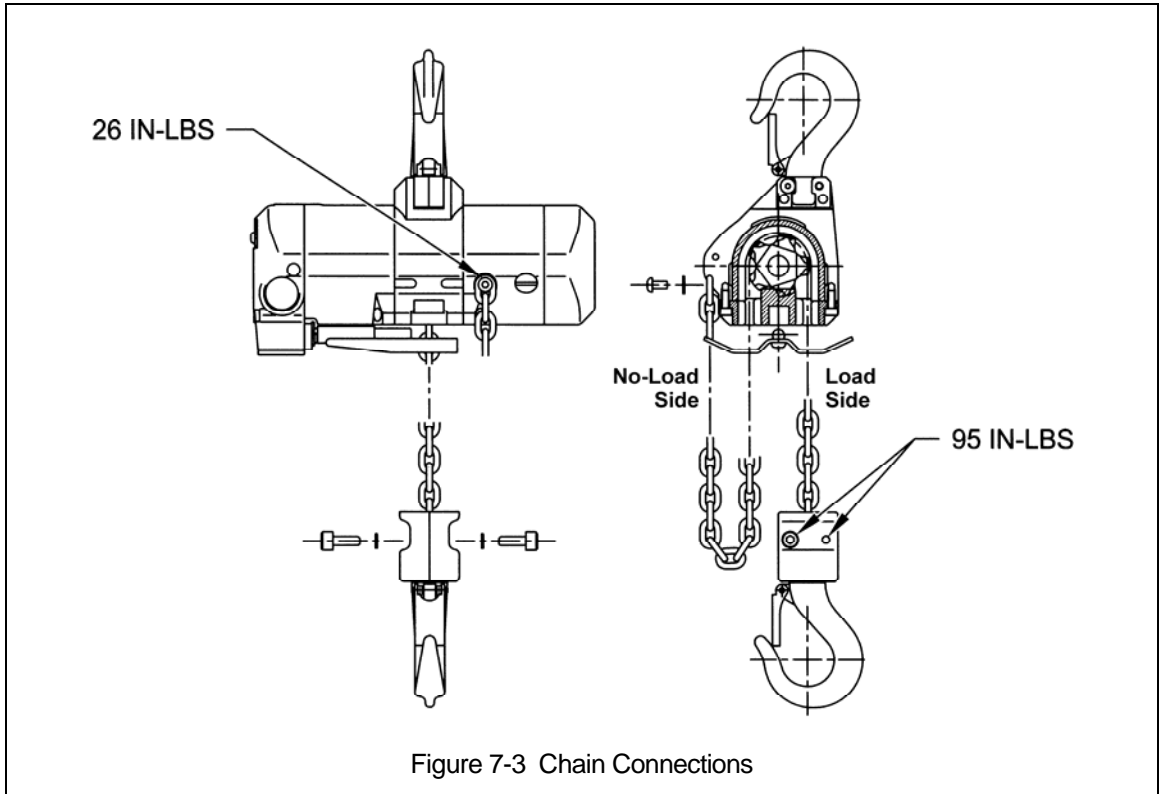
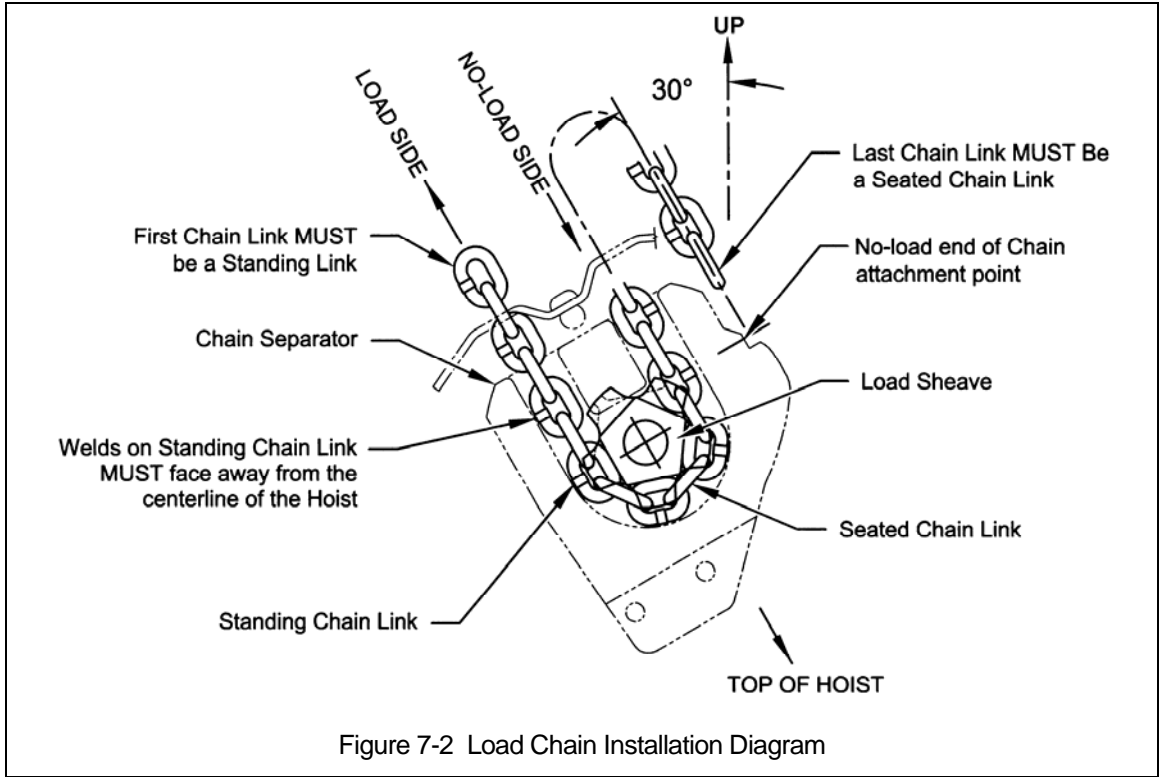

## 7.3 Pendant and Manipulator

7.3.1 The following procedure covers the installation of the molded tubing version of the Pendant Hose (Parts List Figure Number 154) and the Pendant Valve CP. Refer to [Figure 7-4](#).

- 1) Place boots on the ends of the Pendant Hose.
- 2) Firmly press the individual color-coded pendant tubes completely into the Tube Fittings on the Pendant Valve CP and Manifold Block until they bottom out. Refer to [Figure 7-4](#) for the correct placement of the tubes.
- 3) If it is necessary to remove the tubes, press the release ring on the Tube Fitting at the tube inlet and the tube is released.
- 4) Slide the Boots into place over the Tube Fittings at the Manifold Block and Pendant Valve CP.
- 5) **⚠ CAUTION** Operate hoist and make sure the direction of hook travel agrees with the control levers on the Pendant Valve CP.

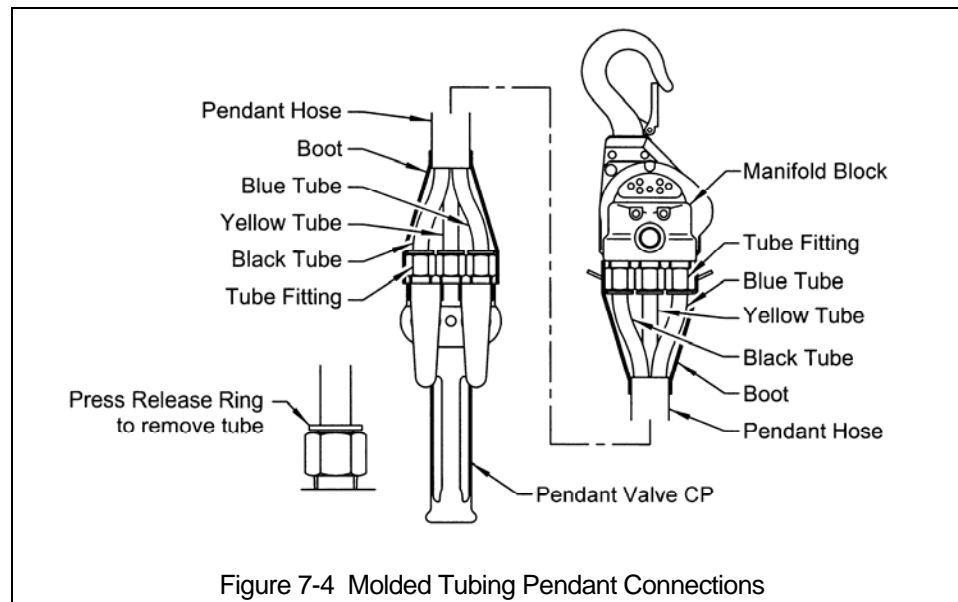

Figure 7-4 Molded Tubing Pendant Connections

7.3.2 The following procedure covers the installation of the 3 Hose version of the Pendant Hose (Parts List Figure Number 153) and the Pendant Valve CP. Refer to [Figure 7-5](#).

- 1) Place boots on the ends of the Pendant Hoses.
- 2) Unscrew the Threaded Sleeves from all Hose Fittings and place them on the ends of the Pendant Hoses.
- 3) Firmly press the Pendant Hoses completely into the Hose Fitting Nipples on the Pendant Valve CP and Manifold Block. Tighten the Threaded Sleeves onto the Hose Fittings until they bottom out. Refer to [Figure 7-5](#) for the correct placement of the Hoses.
- 4) Attach the Strain Relief Chain to the Eye Bolts on the Pendant Valve CP and Manifold Block using the S-Type Wires.
- 5) Slide the Boots in to place over the Hose Fittings at the Manifold Block and Pendant Valve CP.
- 6) **⚠ CAUTION** Operate hoist and make sure the direction of hook travel agrees with the control levers on the Pendant Valve CP.

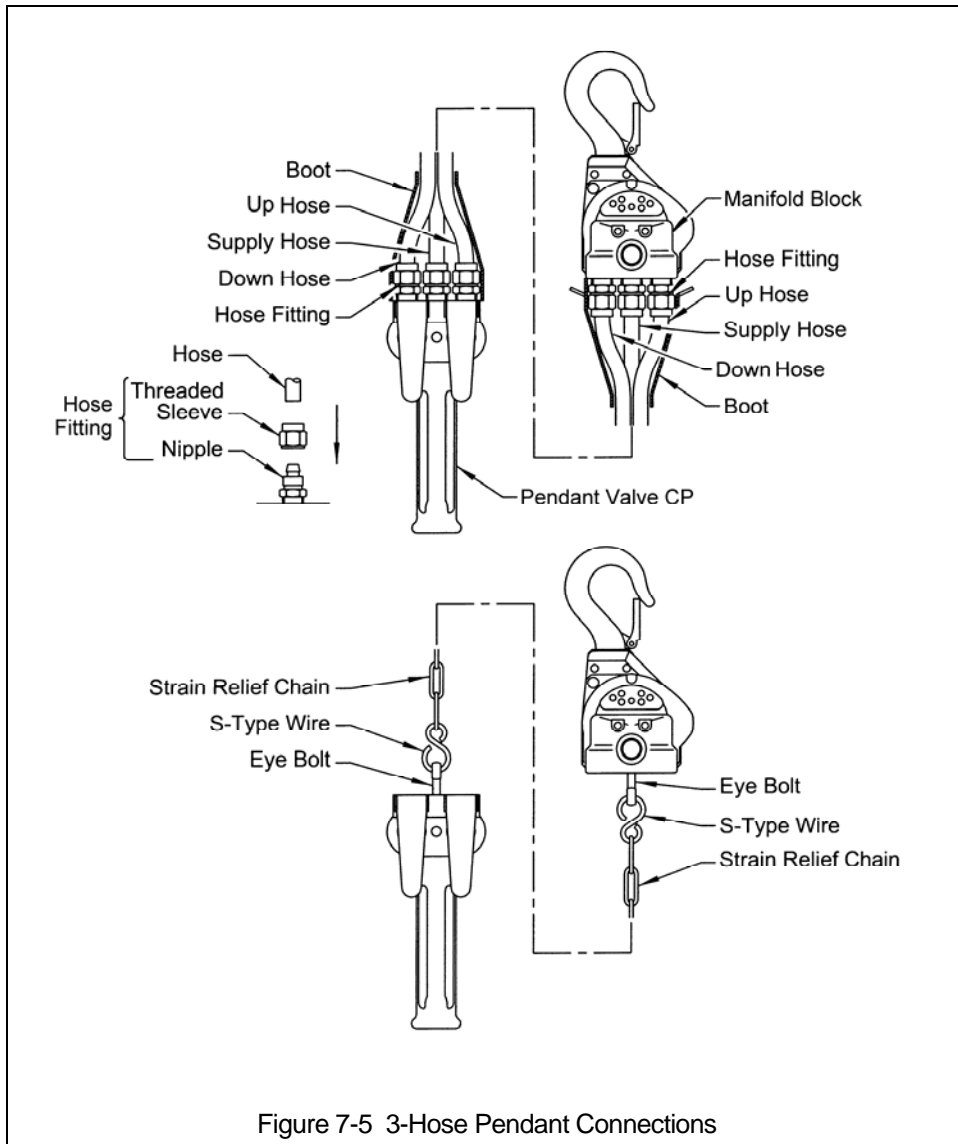

Figure 7-5 3-Hose Pendant Connections

7.3.3 The following procedure covers the installation of the Coil Hose (Parts List Figure Number 202) onto the Manifold Block and Manipulator Control. Refer to [Figure 7-6](#).

- 1) Insert all 3 hoses through the large opening in the Hose Support. Slide the Hose Support around approximately 1 coil of the hose.
- 2) At the hoist, insert all 3 hoses through the Hose Arm attached to the hoist body then insert the Down Tube through the small opening in the Hose Support.
- 3) Firmly press the 3 Pendant Hoses completely into the Hose Fittings on the Manifold Block until they bottom out. Refer to [Figure 7-6](#) for the correct placement of the Hoses.
- 4) At the Manipulator Control, insert all 3 hoses through the Hose Hole on the Manipulator Control.
- 5) Firmly press the 3 Pendant Hoses completely into the Hose Fittings on the Manipulator Control until they bottom out. Refer to [Figure 7-6](#) for the correct placement of the Hoses.
- 6) **⚠ CAUTION** Operate hoist and make sure the hook travel is in the same direction as shown on Manipulator Control.

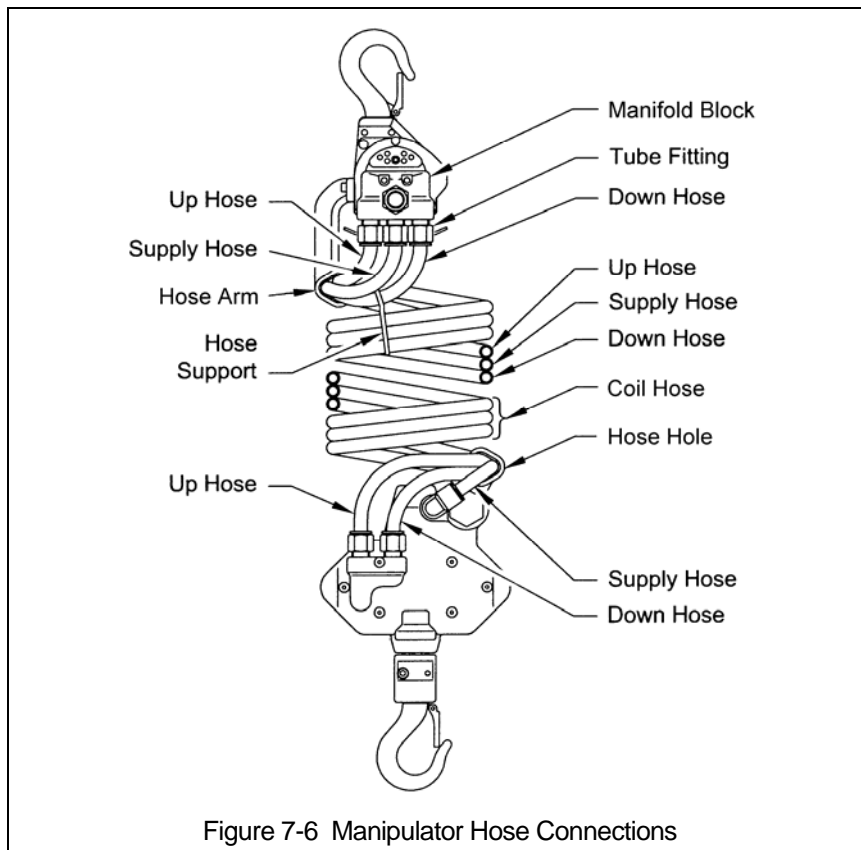
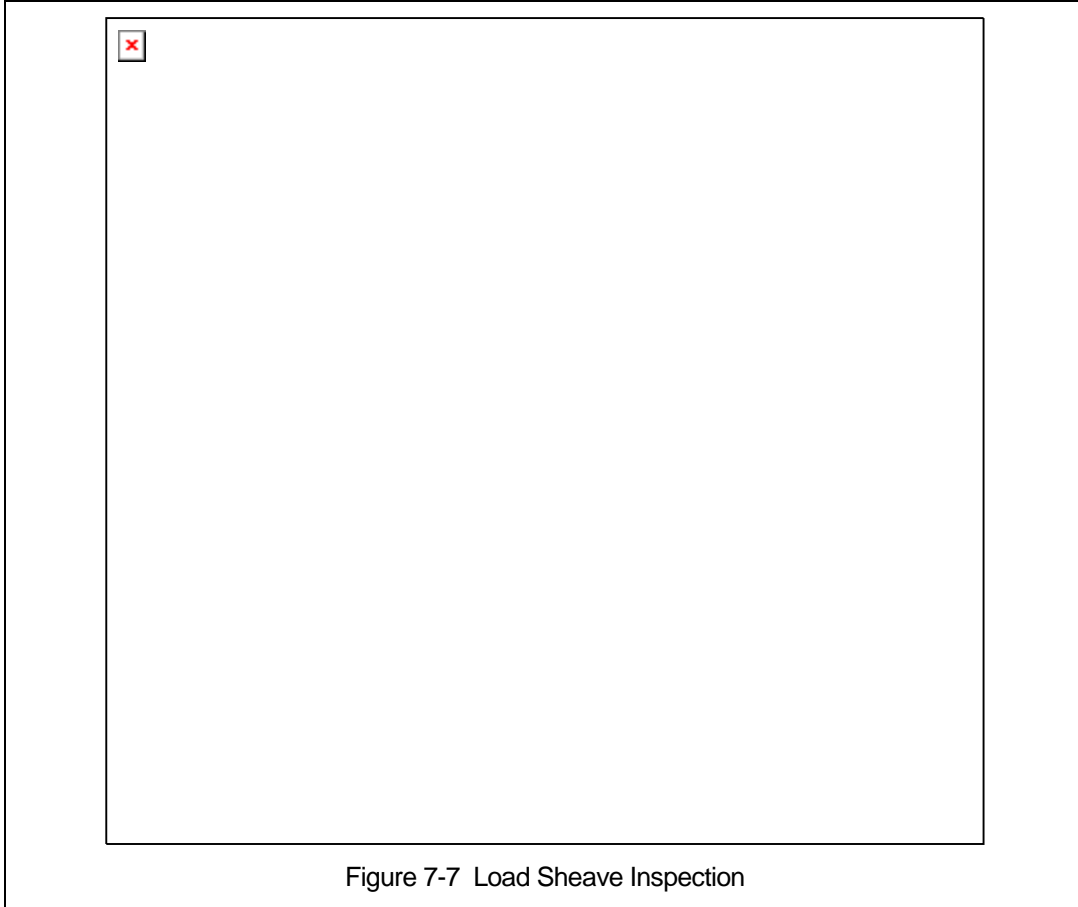

Figure 7-6 Manipulator Hose Connections

## 7.4 Load Sheave Inspection

7.4.1 Perform this inspection by removing the chain separator and viewing the load sheave while operating the hoist slowly, with no load, and in accordance with Section 4 "Operation". Refer to [Figure 7-7](#) and remove the chain separator as follows:

- 1) **CAUTION** An air supply line must be connected to the hoist in order to perform the following procedures.
- 2) Remove the 2 Button Head Screws attaching the chain lever to the limit shaft.
- 3) Remove 2 Socket Bolts attaching the Chain Separator to the Wheel Housing and drop the Chain Separator down.
- 4) Inspect the Load Sheave. Refer to "Load Sheave" in [Table 5-3](#), "Hoist Inspection Methods and Criteria".
- 5) Reverse the procedure to reassemble the hoist.



## 7.5 Storage

- 7.5.1 Whenever the hoist is to be placed into storage, place extra lubricating oil into the air inlet opening and circulate the air motor before plugging the inlet. Make certain that no debris, dirt or moisture is allowed to enter the air hoist through air inlet opening during preparations for storage.
- 7.5.2 The storage location should be clean and dry.

## 7.6 Outdoor Installation

- 7.6.1 For hoist installations that are outdoors, the hoist should be covered when not in use.
- 7.6.2 In order to prevent internal corrosion from occurring, the hoist must be operated using proper quality air at least once per week by raising and lowering the hoist one full cycle. Note: the possibility of corrosion in the valve section of the hoist increases for areas where salt air and high humidity are present. For such situations you may need to operate your hoist more often than once per week.

## 8.0 Troubleshooting

### **WARNING**

**HAZARDOUS AIR PRESSURE IS PRESENT IN THE HOIST, IN THE SUPPLY OF COMPRESSED AIR TO THE HOIST, AND IN CONNECTIONS BETWEEN COMPONENTS.**

Before performing ANY maintenance on the equipment, de-energize the supply of compressed air to the equipment, and lock and tag the supply device in the de-energized position. Refer to ANSI Z244.1, "Personnel Protection - Lockout/Tagout of Energy Sources."

Only Trained and competent personnel should inspect and repair this equipment.

**Table 8-1 Troubleshooting Guide**

Symptom	Cause	Remedy
Does not operate	Lack of air pressure or loss of air supply.	Repair or adjust air supply or filters.
	Seizure of Main Spool, brake Shuttle, or Air Motor.	Repair at service facility.
	Seizure of brake or brake mechanism fails to release.	Repair at service facility.
	Hoist is overloaded.	Reduce the load to the rated capacity of hoist.
Lifting speed is slow	Low air pressure at hoist inlet port.	Repair or adjust air supply or filters. Check for air line obstruction.
	Air supply hose or piping is too small.	Replace hose or piping sizes with recommended sizes in <b>Section 3.0</b> .
	Malfunction of brake.	Repair at service facility.
	Lack of sufficient oil in air supply to hoist	Increase oil in air supply to hoist in accordance with requirements in <b>Section 3.0</b> .
	Exhaust Silencer S or Silencer F clogged	Clean or replace.
	Air flow capacity of compressed air system insufficient	Increase air flow capacity of compressed air system to requirements in <b>Section 2.0</b> .
	Air motor Vanes or bearings worn	Repair at service facility.
	Air supply to hoist contains dirt or debris	Filter the air supply to the hoist in accordance with the requirements in <b>Section 3.0</b> .
Unable to lift rated load	Lack of air pressure or loss of air supply.	Repair or adjust air supply or filters.
Hoist lowers but will not lift	Hoist is overloaded.	Reduce load to hoist rated capacity.
	Lack of air pressure or partial loss of or leakage in air supply.	Repair or adjust air supply or filters.

**Table 8-1 Troubleshooting Guide**

<b>Symptom</b>	<b>Cause</b>	<b>Remedy</b>
Hoist continues running after pendant or cord is released	Main Spool sticking	Inject approx. 20 drops of oil into inlet port to lubricate the main spool. If spool still sticks, repair at service facility.
	Valve Spring broken	Repair at service facility
	Main Spool leaking	Repair at service facility
	Valve in Pendant Valve CP stuck	Repair at service facility
Hoist drifts excessively when hoist is stopped	Brake is not holding.	Repair brake at service facility.
	Motor Vanes leaking.	Replace motor Vanes at service facility.
Hoist moving in wrong direction	Mis-connected Pendant Hose assembly.	Reconnect Pendant Hose correctly.

## 9.0 Warranty

Warranty explanation and terms.

All products sold by Harrington Hoists, Inc. are warranted to be free from defects in material and workmanship from date of shipment by Harrington for the following periods:

**Manual Hoists & Trolleys - 2 years**

**Air and Electric Powered Hoists, Trolleys, and Crane Components - 1 year**

**Spare / Replacement Parts - 1 year**

The product must be used in accordance with manufacturer's recommendations and must not have been subject to abuse, lack of maintenance, misuse, negligence, or unauthorized repairs or alterations.

Should any defect in material or workmanship occur during the above time period in any product, as determined by Harrington Hoist's inspection of the product, Harrington Hoists, Inc. agrees, at its discretion, either to replace (not including installation) or repair the part or product free of charge and deliver said item F.O.B. Harrington Hoists, Inc. place of business to customer. Customer must obtain a Return Goods Authorization as directed by Harrington or Harrington's published authorized repair center prior to shipping product for warranty evaluation. An explanation of the complaint must accompany the product. Product must be returned freight prepaid. Upon repair, the product will be covered for the remainder of the original warranty period. If it is determined there is no defect, or that the defect resulted from causes not within the scope of Harrington's warranty, the customer will be responsible for the costs of returning the product.

Harrington Hoists, Inc. disclaims any and all other warranties of any kind expressed or implied as to the product's merchantability or fitness for a particular application. Harrington will not be liable for death, injuries to persons or property or for incidental, contingent, special or consequential damages, loss or expense arising in connection with the use or inability whatever, regardless of whether damage, loss or expense results from any act or failure to act by Harrington, whether negligent or willful, or from any other reason.

**This Page Intentionally Left Blank**

# 10.0 Parts List

When ordering Parts, please provide the Hoist code number and serial number located on the Hoist nameplate (see [Figure 10.1](#) below).

Reminder: Per [Sections 1.1 and 3.14](#) to aid in ordering Parts and Product Support, record the Hoist code and serial number in the space provided on the cover of this manual.

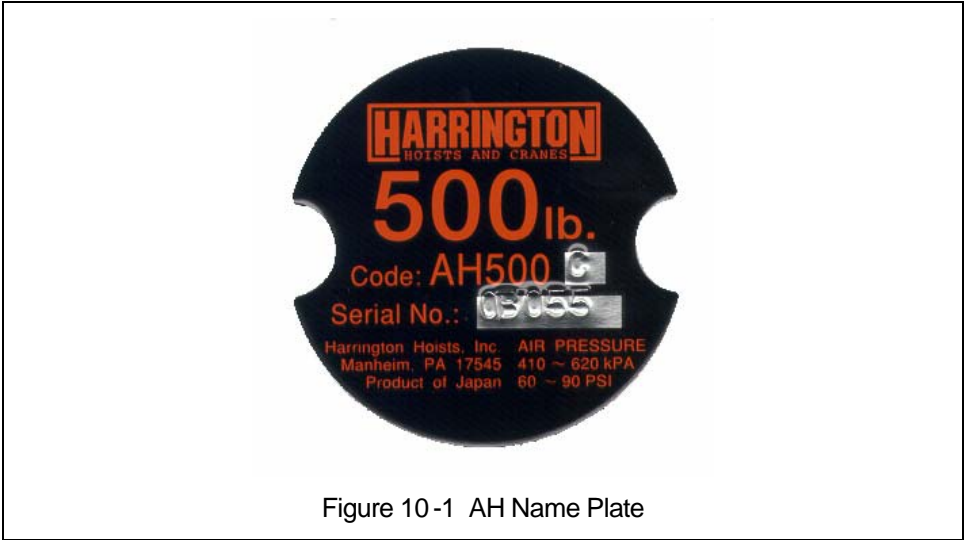

The parts list is arranged into the following sections:

Section	Page
10.1 Main Body.....	48
10.2 Valve Body.....	50
10.3 Manipulator Control.....	52
10.4 Optional Components.....	54

# 10.1 Main Body

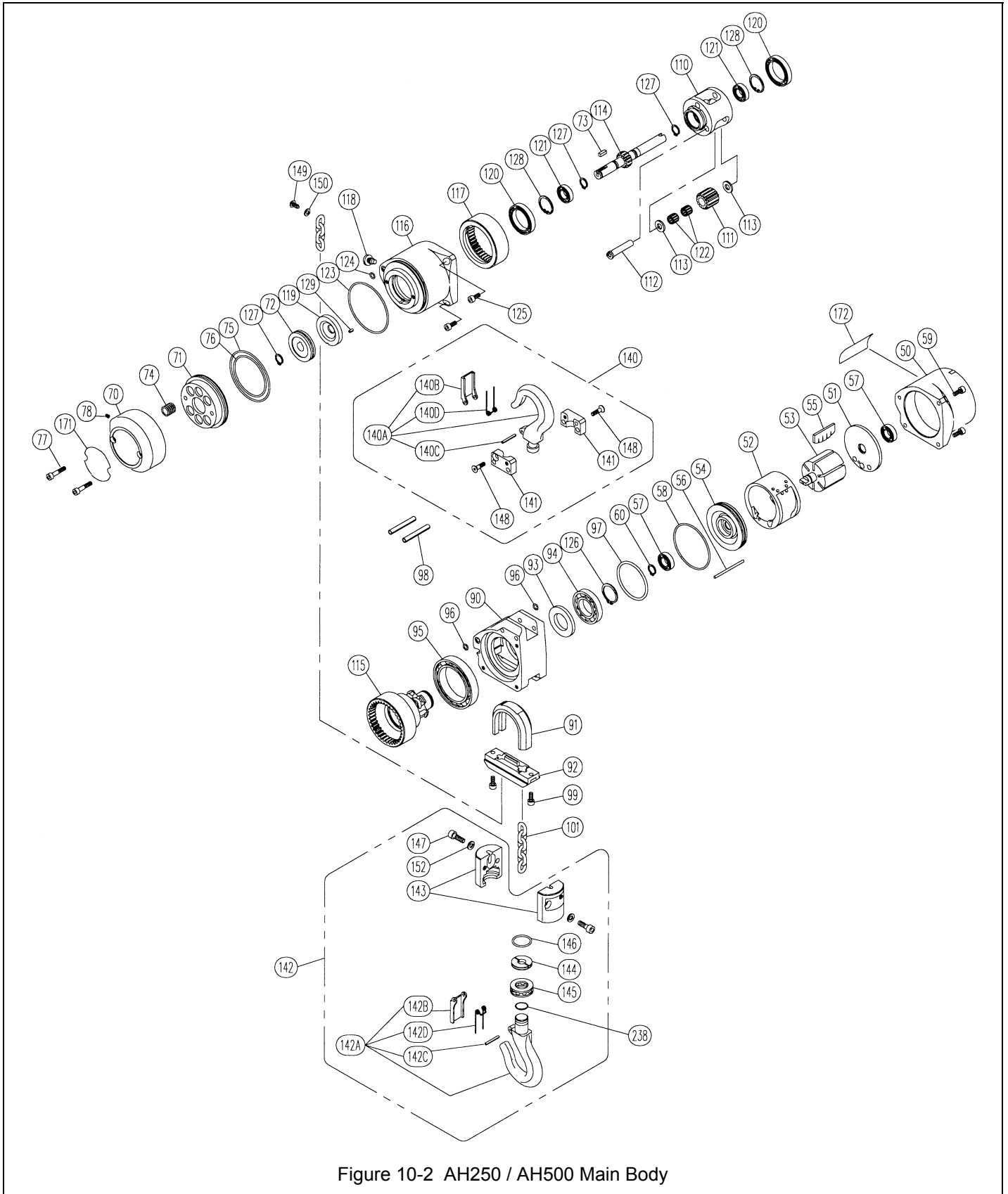
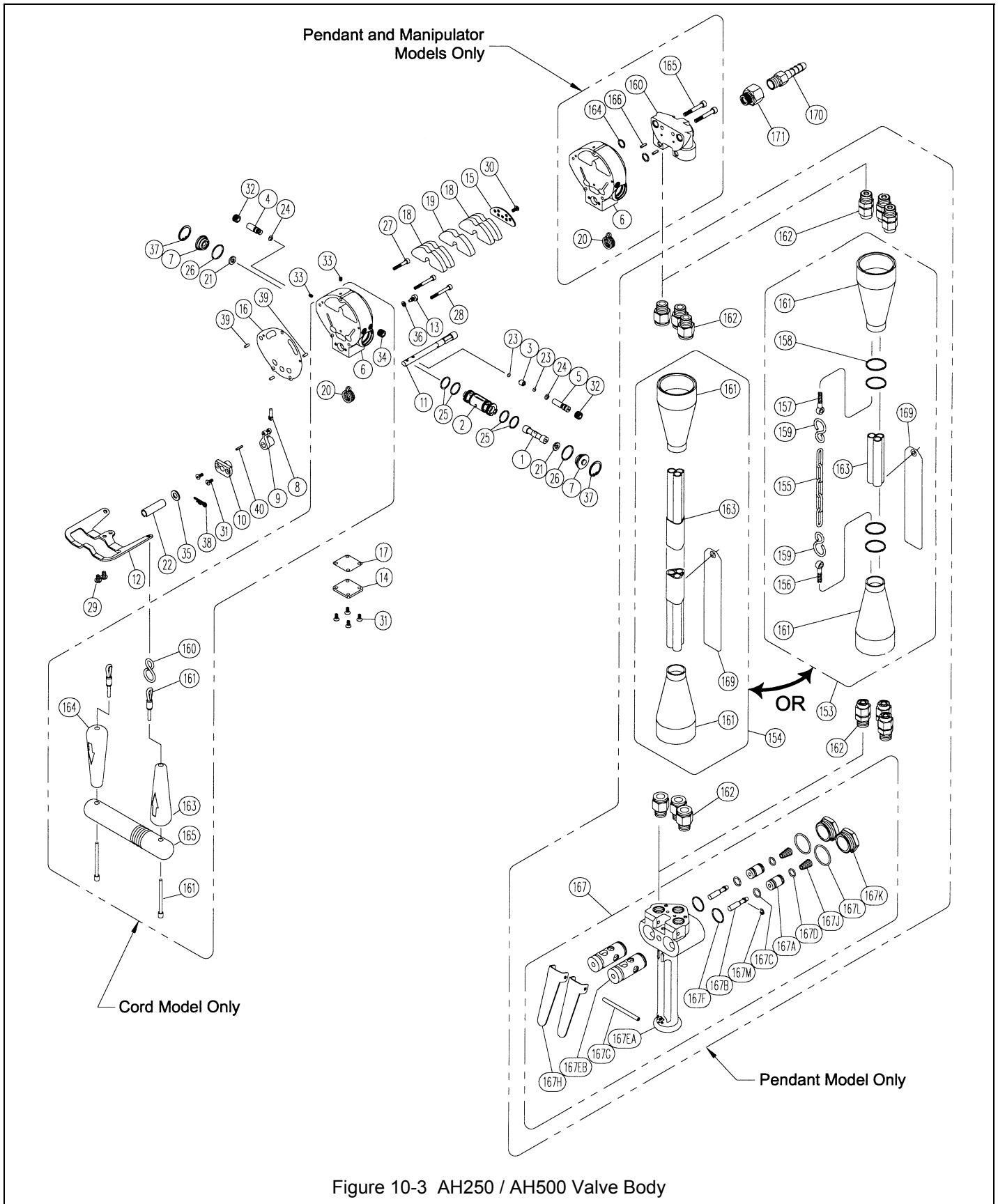

Figure 10-2 AH250 / AH500 Main Body

Figure Number	Name	Parts Per Hoist	Part Number
50	Motor Case	1	AH426205790
51	Rear Plate	1	AH426205180
52	Cylinder	1	AH426205160
53	Rotor	1	AH426205150
54	Front Plate	1	AH426205170
55	Vane	6	AH137102018
56	Knock Pin	1	AH130402049
57	Bearing	2	9001208
58	O-Ring	1	AH131103044
59	Socket Bolt	3	9091227
60	Retaining Ring	1	9047112
70	Brake Cover	1	AH426205410
71	Brake Piston	1	AH426205400
72	Brake Disk	1	AH426205430
73	Key	1	AH130408079
74	Brake Spring	6	AH130802207
75	O-Ring	1	AH131103047
76	O-Ring	1	AH131103042
77	Socket Bolt	2	9091231
78	Set Screw	1	AH132104005
90	Wheel Housing – Cord and Pendant Models	1	AH426205210
	Wheel Housing – Manipulator Model	1	AH426215210
91	Chain Guide	1	AH426205350
92	Chain Separator	1	AH136610025
93	Spacer	1	AH426205230
94	Bearing	1	9001207
95	Bearing	1	9001205
96	O-Ring	2	TCR131103004
97	O-Ring	1	AH131102006
98	Spring Pin	2	91481110
99	Socket Bolt	2	9091227
101	Load Chain	FT	LCED125
110	Cage	1	AH426205240
111	Star Gear	3	AH426205250
112	Pin	3	AH426205260
113	Thrust Collar	6	AH426205270
114	Pinion	1	AH426205290
115	Load Sheave	1	AH426205300
116	Gear Case	1	AH426205310
117	Ring Gear	1	AH426205320

Figure Number	Name	Parts Per Hoist	Part Number
118	Lock Screw	1	AH426205890
119	Brake Plate	1	AH426205900
120	Bearing	2	9001206
121	Bearing	2	9001208
122	Needle Bearing	6	AH130170013
123	O-Ring	1	AH131103047
124	O-Ring	1	TCR131103004
125	Socket Bolt	3	9091227
126	Retaining Ring	1	9047125
127	Retaining Ring	3	9047112
128	Retaining Ring	2	9047224
129	Spring Pin	1	9148121
140	Top Hook Complete Set	1	AH42620557C
140A	Top Hook Assy.	1	AH420810PAA
	140B Hook Latch	1	AH420620P10
	140C Spring Pin	1	TCR130603024
	140D Latch Spring	1	TCR130802046
141	Top Yoke Pair	1	AH426205570
148	Hex Flat Head Machine Screw	2	AH132805018
142	Bottom Hook Complete Set – 250 lbs	1	AH42620593H
	Bottom Hook Complete Set – 500 lbs	1	AH42620593C
142A	Bottom Hook Assy.	1	AH42620593A
	142B Hook Latch	1	AH420620P10
	142C Spring Pin	1	TCR130603024
	142D Latch Spring	1	TCR130802046
143	Bottom Yoke Pair – 250 lbs	1	AH42620580H
	Bottom Yoke Pair – 500 lbs	1	AH426205800
144	Hook Thrust Plate Pair	1	AH426205910
145	Thrust Bearing	1	AH130121103
146	O-Ring	1	AH131103017
147	Socket Bolt	2	9091250
152	Spring Washer	2	AH131310006
149	Button Head Screw	1	AH131905010
150	Washer	1	9012510
170	Brand Name Plate	1	AH137309264
171	Name Plate – AH250	1	80064
	Name Plate – AH500		AH137309262
172	Logo Name Plate	1	80063
238	O-Ring – Manipulator Model Only	1	AH131101015

## 10.2 Valve Body



Valve Body

Figure Number	Name	Parts Per Hoist	Part Number
1	Main Spool	1	AH426205010
2	Valve Bush	1	AH426205780
3	Shuttle	1	AH426205870
4	Valve Seat R	1	AH426205830
5	Valve Seat L	1	AH426205840
7	Side Cover	2	AH426205080
8	Valve Pin	1	AH426205850
9	Limit Lever	1	AH426205140
10	Limit Guide	1	AH426205100
11	Limit Shaft	1	AH426205460
12	Chain Lever	1	AH426205110
13	Stopper	1	AH426205860
14	Under Cover	1	AH426205470
15	Exhaust Plate	1	AH426205810
16	Valve Packing	1	AH136102151
17	Under Packing	1	AH136102153
18	Silencer S	4	AH137402022
19	Silencer F	1	AH137402021
21	Bumper	2	AH136406025
22	Protector	1	AH426205880
23	O-Ring	2	AH131117004
24	O-Ring	2	AH131103003
25	O-Ring	4	AH131103014
26	O-Ring	2	AH131103016
27	Socket Bolt	1	9091209
28	Socket Bolt	2	9091210
29	Button Head Screw	2	AH131905008
30	Button Head Screw	1	AH131904008
31	Hex Flat Head Machine Screw	6	AH132804010
32	Set Screw	2	AH132110008
33	Set Screw	3	AH132104005
35	Washer	1	9012513
36	Washer	1	9012510
37	Retaining Ring	2	9047222
38	Hair Pin Cotter	1	AH130790008
39	Parallel Pin	3	AH130406017
40	Spring Pin	1	9148116
170	Hose Stem	1	AH134803040
171	Inlet Bushing w/Screen	1	AH134703050

**Pendant and Manipulator Models Only:**

Figure Number	Name	Parts Per Hoist	Part Number
6	Valve Body	1	AH426206060
20	Valve Spring	1	AH130802209
160	Manifold Block	1	AH426206941
164	O-Ring	2	TCR131103008
165	Socket Bolt	2	9091232
166	Spring Pin	2	9148123

**Cord Model Only:**

Figure Number	Name	Parts Per Hoist	Part Number
6	Valve Body	1	AH426205060
20	Valve Spring	1	AH130802208
34	Hex Socket Pipe Plug	1	TCR134902003
160	S-Type Wire	2	TCR130802081
161R	Red Cord (Down)	FT	9013102
161W	White Cord (Up)	FT	9013101
163	Grip W	1	AH136602625
164	Grip R	1	AH136602626
165	Handle	1	AH136602627

**Pendant Model Only:**

Figure Number	Name	Parts Per Hoist	Part Number
153	Pendant Hose Assy. (Three hoses)	1	60472
155	Cord Chain	FT	ES625003
156	Eye Bolt	1	9044403
157	Eye Bolt	1	9044401
158	Split Ring	A/R	AH130802093
159	S-Type Wire	2	TCR130802081
161	Boot	2	AH136608250
163	Hose	3@FT	9013141
169	Warning Tag	1	WTAG7
162	Hose Fittings	6	AH137291310
154	Pendant Tube Assy. (Molded Tubing)	1	60471
161	Boot	2	AH136608250
163	Pendant Hose	FT	AH1372400HS
169	Warning Tag	1	WTAG7
162	Tube Fitting	6	AH137288030
167	Pendant Valve CP	1	AH420215VBC
167A	Throttle Valve	2	AH420215VB0
167B	Push Rod	2	AH420215VC0
167C	O-Ring	2	AH131118012
167D	O-Ring	2	AH131117013
167E	Pendant Valve Body CP	1	AH420215VRB
167EA	Pendant Valve Body	1	AH420215VR0
167EB	Bushing	2	AH420214VF0
167F	O-Ring	2	AH131103016
167G	Spring Pin	2	9148176
167H	Pendant Valve Lever	2	AH420210VH0
167J	Valve Spring	2	AH130802030
167K	Pendant Valve Cap	2	AH420214V10
167L	O-Ring	2	TCR131103022
167M	E-Ring	2	AH130303004

### 10.3 Manipulator Control

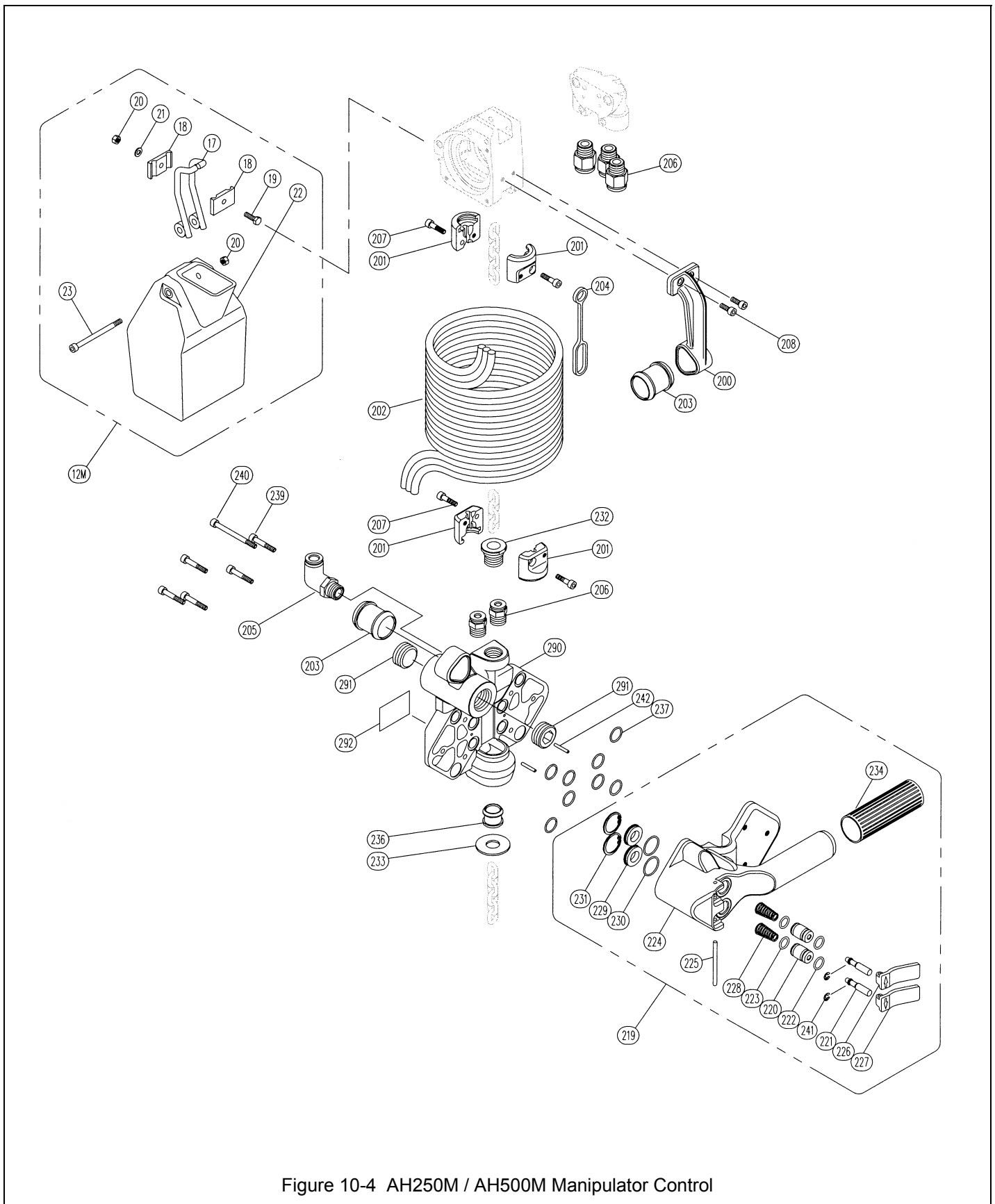

Figure 10-4 AH250M / AH500M Manipulator Control

## Manipulator Control

Figure Number	Name	Parts Per Hoist	Part Number
12M	Chain Basket CP	1	AH42621592C
17	Bucket Arm Assembly (pair)	1 pr.	AH426205920
18	Arm Holder	2	AH426205820
19	Bolt	1	90933177
20	U-Nut	2	E2D853125
21	Washer	1	9012510
22	Chain Basket	1	AH139003026
23	Socket Bolt	1	9091239
200	Hose Arm	1	AH426215960
201	Hanger Half	4	AH426215B30
202	Coil Hose – Std. 6.5 ft lift	1	AH137202018
	Coil Hose – Opt. 13 ft lift	1	AH137202019
203	Rubber Bushing	2	AH136608252
204	Hose Support	1	AH136608253
205	Tube Fitting	1	AH137289310
206	Tube Fitting	5	AH137290310
207	Socket Bolt	4	9091229
208	Socket Bolt	2	9091227
219	Throttle Valve Complete	1	AH42621597D
220	Throttle Valve	2	AH420215VB0
221	Push Rod	2	AH420215VC0
222	O-Ring	2	AH131118012
223	O-Ring	2	AH131117013
224	Throttle Valve Body CP	1	AH42621597B
225	Lever Pin	1	AH130402048
226	Throttle Lever Up	1	AH420985UY0
227	Throttle Lever Down	1	AH420985UZ0
228	Valve Spring	2	AH130802221
229	Spring Seat	2	AH426215B00
230	O-Ring	2	AH131103016
231	Retaining Ring	2	9047224
234	Grip	1	AH136608140
241	Retaining Ring	2	AH130303004
232	Rotary Joint	1	AH426215B40
233	Hook Protector	1	AH136201200
236	Rubber Bushing	1	AH136608251
237	O-Ring	8	AH131103013
238	O-Ring	1	AH131101015
239	Button Head Screw	5	AH131905030

Figure Number	Name	Parts Per Hoist	Part Number
240	Button Head Screw	1	AH131905060
242	Spring Pin	2	9148123
290	Shield	1	AH426215B20
291	Hex Socket Pipe Plug	2	AH134901006
292	Manipulator Warning Tag	1	AH137304071

## 10.4 Optional Components

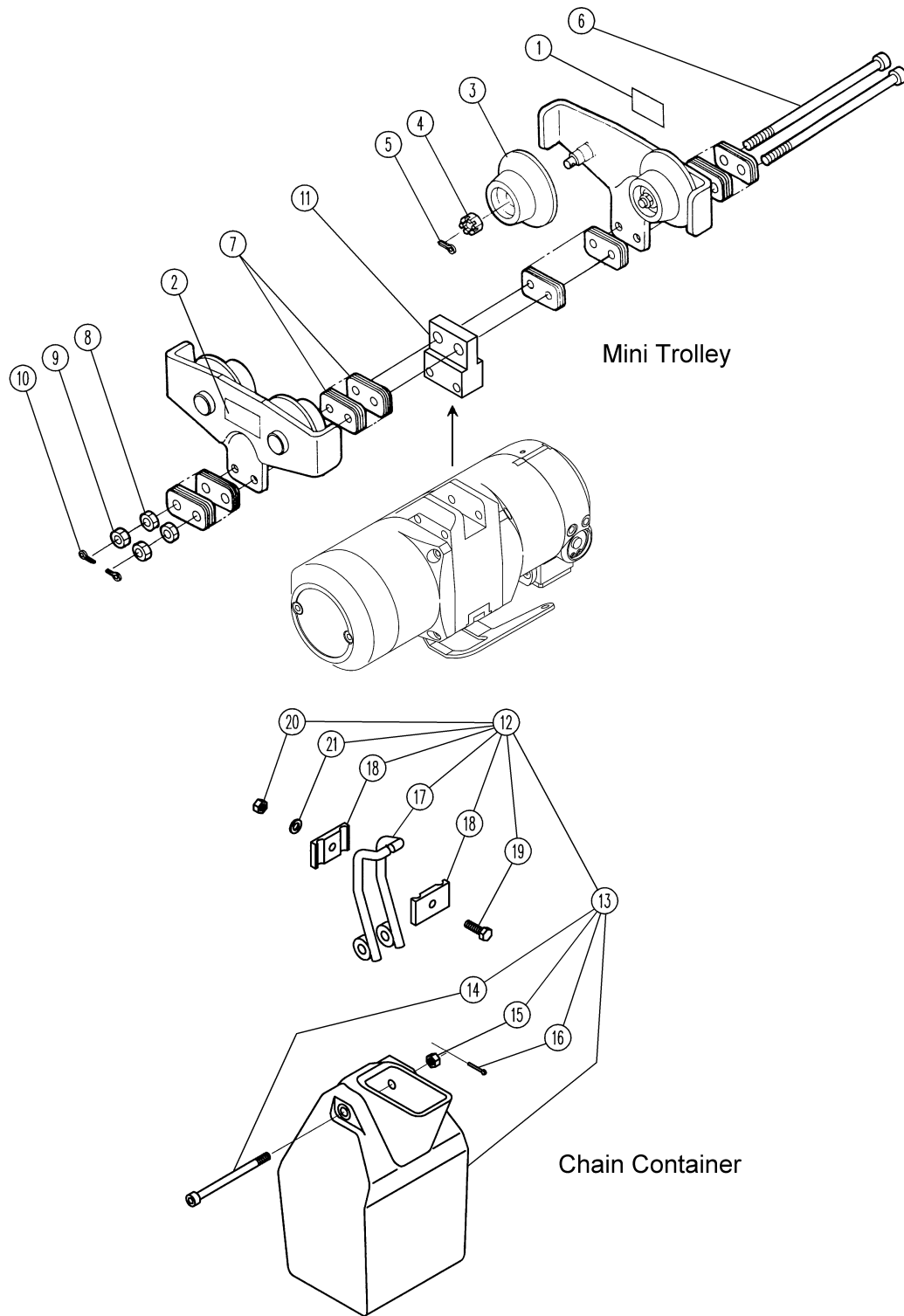

Figure 10-5 Optional Components

Mini Trolley:

Figure Number	Name	Parts Per Trolley	Part Number
1	Name Plate C	1	ET25801525
2	Name Plate B	1	ET25800525
3	Track Wheel Assembly	4	ET255102525
4	Slotted Nut	4	M2049010
5	Split Pin	4	9009411
6	Socket Bolt	2	ET25115525
7	Adjusting Spacer	32	ET25116525
8	Nut	2	9093424
9	U-Nut	2	ET25155525
10	Split Pin	2	9009411
11	Suspender	1	60456

Chain Containers for Cord and Pendant Models\*:

Figure Number	Name	Parts Per Hoist	Part Number	
			10 ft Max. Lift	20 ft Max. Lift
12	Chain Container CP	1	K00037	K00038
13	Chain Container – For Cord and Pendant Models Only*	1	E2D1831125	E2D1835125
14	Socket Bolt BP	1	E2D854125	
15	U-Nut	1	E2D853125	
16	Split Pin	1	9009402	
17	Bucket Arm Assembly (pair)	1 pr.	AH426205920	
18	Arm Holder	2	AH426205820	
19	Bolt	1	90933177	
20	U-Nut	1	E2D853125	
21	Washer	1	9012510	

\*See page 52 & 53 “Manipulator Control” for the Manipulator Chain Container.



[www.harringtonhoists.com](http://www.harringtonhoists.com)

**Harrington Hoists, Inc.**  
401 West End Avenue  
Manheim, PA 17545  
Phone: 717-665-2000  
Toll Free: 800-233-3010  
Fax: 717-665-2861

**Harrington Hoists - Western Division**  
2341 Pomona Rd. #103  
Corona, CA 92880-6973  
Phone: 951-279-7100  
Toll Free: 800-317-7111  
Fax: 951-279-7500

**AHOM**